

MOROSINI®
luce & design

NEWS 2017

EviStyle®

MOROSINI[®]
luce & design

NEWS 2017

EviStyle[®]

Index

BIA : 60
CUEVA : 40
MEMORIA : 84
MIKADO : 26
MINERVA : 70
PANK : 44
RAMETTO : 12
SAN MARCO : 100
SANTRAL : 34
TROTTOLA : 50
VANE : 06
VINTAGE : 92

LEGENDA : 108

Designers



manuel borri
DIAGORA
DESIGN



CHIARAMONTEMARIN



dima
LOGINOFF



filippo
MAMBRETTI



tiziano
MAFFIONE



stefano
MANDRUZZATO



romani sacconi
ARCHITETTI
ASSOCIATI

MOROSINI[®]
luce & design

EviStyle[®]



VANE



Romani Saccani
Architetti Associati

Connubio di geometrie
protagoniste
in ogni contesto

Combination of geometries
which become protagonists
in each context



Vane_PA1



Vane_PA1

VANE

technical data

Come il segnavento da cui eredita il nome, Vane trova la sua naturale collocazione nei punti chiave dello spazio in cui si inserisce.

Dalla fusione di due geometrie nasce una lampada da parete dalle caratteristiche minimali che spicca per equilibrio delle forme e per funzionalità. La sorgente led, disposta "a bandiera" rispetto alla parete, proietta una luce che è possibile ruotare di 325 gradi, offrendo così una varietà di utilizzo modulabile secondo ogni esigenza. In quest'ottica è stata progettata la sagoma dell'impugnatura, studiata per garantire elevati standard di ergonomia e maneggevolezza. Una dinamicità che trova la sua naturale collocazione sia in ambienti domestici che in contesti contract. L'apparecchio è dimmerabile Triac.

Comme la girouette dont elle tient le nom, Vane est naturellement destinée aux points-clés de l'espace dans lequel on l'installe.

La fusion de deux géométries a donné naissance à une applique aux caractéristiques minimales qui se distingue par l'équilibre des formes et par sa fonctionnalité. La source led, disposée "en drapeau" par rapport au mur, projette une lumière qui peut pivoter de 325°, offrant une variété d'utilisation modulable en fonction des besoins. C'est dans cette optique que l'on a façonné une poignée en mesure de garantir de hauts standards d'ergonomie et de maniabilité. Un dynamisme qui s'intègre avec naturel dans les espaces domestiques et des collectivités. L'appareil est dimmable Triac.

Vane, whose name derives from the weather vane, wherever it is placed it finds its natural space.

This wall lamp arises from the merger of two geometries with minimal features and stands out for the formal balance and functionality.

The source led, placed as a "flag" to the wall, beams a light that can be rotated 325 degrees, providing a variety of uses modulated according to all needs. In order to reach this modularity, the grip has a specific shape, designed to ensure high ergonomic and handling standards. A dynamic that finds its natural place both in private and public use. The device is dimmable Triac.

Como la veleta de la que hereda su nombre, Vane encuentra su colocación natural en cualquier sitio se ponga.

De la unión entre dos geometrías, nace una lámpara de pared que sobresale por su carácter minimal, su equilibrio de formas y su funcionalidad.

La fuente led, que se dispone a bandera con respecto a la pared, proyecta una luz que se puede girar de 325°, ofreciendo una variedad de usos que se ajustan a las necesidades. En esta óptica se ha diseñado el perfil de la empuñadura, estudiada para garantizar altos estándares de ergonomía y manejabilidad. Ese dinamismo permite colocarla en entornos tanto domésticos como de contract. El aparato es regulable Triac.

Wie die Windfahne, von der sie ihren Namen erhält, findet Vane ihren natürlichen Einsatz in den Schlüsselpunkten des Raums, in den sie eingegliedert wird.

Aus der Verbindung zweier Geometrien entstand eine Wandlampe mit Minimal-Eigenschaften, die dank des Ausgleichs der Formen und der Funktion herausragt. Die Led-Lichtquelle, die gegenüber der Wand „wie eine Fahne“ angeordnet ist, projiziert ein Licht, das um 325 Grad gedreht werden kann, wodurch eine veränderbare Nutzung je nach Anforderung möglich ist. In diesem Rahmen wurde die Form des Griffs entworfen, um eine hohe Ergonomie und eine einfache Bedienung zu gewährleisten. Eine Dynamik, die ihre natürliche Anordnung im Haus wie in Contract-Umgebungen findet. Das Gerät ist über Triac dimmbar.

Vane - в переводе флюгер, где бы ни находился, везде находит для себя подходящее пространство.

Это бра возникает в результате слияния двух геометрических форм, с минимальным количеством особенностей и выделяется своим балансом и функциональностью.

Светодиодный источник света закреплён на стене как флажок, дающий на стену луч света и вращающийся на 325 градусов, обеспечивает множество возможных применений. Для того, чтобы достичь такой вариативности, «голове» светильника придали специальную форму, обеспечивающую высокую эргономичность. Такой функциональности найдётся применение как в частном, так и в общественном интерьере. Светильник может диммироваться с помощью TRIAC.

Struttura: metallo nelle colorazioni: bianco opaco, nero opaco, oro opaco, rame opaco.

Diffusore: Policarbonato satinato.

Frame: metal in the colors: matt white, matt black, matt gold, matt copper.

Diffuser: Polycarbonate satin finish.

Struktur: Metall in den Farben: Mattweiß, Mattschwarz, Mattgold, Mattkupfer.

Diffusor: Satiniertes Polycarbonat.

Structure: métal dans les teintes: blanc mat, noir mat, or mate, cuivre mat.

Diffuseur: Polycarbonate satiné.

Estructura: metal en los colores: blanco mate, negro mate, oro mate, cobre mate.

Difusor: Policarbonato satinado.

Структура: металл окрашенный в матовый белый, матовый чёрный, матовый золотой или матовый медный цвет.

Рассеиватель: матовый поликарбонат



BI: Bianco opaco/
Matt White



NE: Nero opaco/
Matt Black



OR: Oro opaco/
Matt Gold



RA: Rame opaco/
Matt copper

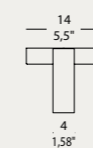
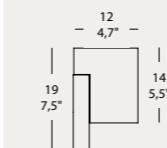

VANE PA1

10W 950 Lm 2700K Cri>80 Acrich 3 230 Vac 50-60 Hz LED

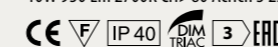



Rametto. 6 x SO S/R + 5 x BA + RO6

RAMETTO



Chiaromonte Marin

Ispirata alla natura, prende
forma attorno a te.

Inspired by nature, it takes
shape around you.





Rametto_SO S/R + IN1



Rametto_2 x SO S/R + RO2



Rametto_3 x SO S/R + RO3



Rametto_6 x SO S/R + RO6



Ramoto_PA1



Ramoto_PA2



Ispirato alle incantevoli ramificazioni degli alberi e al potere evocativo della natura, Rametto esprime la sua personalità unica nel settore dell'illuminazione grazie a due linee guida precise: modularità e interconnessione. Ad unire i singoli elementi in ceramica, disponibili in quattro colorazioni, intervengono dei magneti, lasciando così ampio spazio alla fantasia e alle possibilità di realizzazione di entità di luce totalmente personalizzabili.

Modularity and interconnection: thanks to these two clear guidelines, Rametto expresses a unique personality in the lighting field, inspired by the beautiful branches of the trees and the evocative power of nature. Magnets are used to combine individual ceramic elements, available in four colors, leaving the imagination free and giving the possibility to create totally customised lighting items.

Modularität und Verbindung: Dank dieser beiden klaren Richtlinien, drückt Rametto eine einzigartige Persönlichkeit im Lichtfeld aus, inspiriert von den schönen Zweigen der Bäume und der eindrucksvollen Kraft der Natur. Magnete, erhältlich in vier Farben, werden verwendet, um einzelne Keramikelemente zu kombinieren. Auf diese Weise lassen sie die Phantasie frei und geben die Möglichkeit, völlig individuelle Lichtelemente zu erstellen.

Rametto, qui s'inspire aux ramifications des arbres et au pouvoir évocateur de la nature, exprime sa personnalité unique dans le secteur de l'éclairage, grâce à deux orientations précises : modularité et interconnexion. Les éléments en céramique, disponibles en trois couleurs, s'unissent par des aimants, en laissant l'espace à la fantaisie et à la possibilité de réaliser des œuvres de lumière entièrement personnalisables.

Rametto, que se inspira a las ramificaciones de los árboles y al poder evocador de la naturaleza, expresa su carácter único en el sector de la iluminación, gracias a dos directrices bien definidas: la modularidad y la interconexión. Los elementos de cerámica, disponibles en cuatro colores, se unen gracias a unos imanes, dejando libre la fantasía y la posibilidad de crear piezas de luces personalizables por completo.

Модульность и взаимосвязь - с помощью этих особенностей Rametto выражает свою индивидуальность, вдохновленный прекрасными ветками деревьев и вызывающий к силам природы. Магниты используются для объединения отдельных керамических элементов, доступных в четырех цветах, позволяя создавать индивидуальные предметы освещения.

Struttura: rosone bianco.
Ceramica e parti in metallo nelle colorazioni: bianco opaco, nero opaco, oro opaco, rame opaco.

Frame: white canopy – ceramic and metal parts in the colors: matt white, matt black, matt gold, matt copper.

Struktur: Baldachin: Weiß - Keramik und Metallteile in den Farben: Weißmatt, Schwarz matt, Goldmatt, Kupfermatt.

Structure: rosette blanche – céramique et les parties métalliques dans les couleurs: blanc mat, noir mat, or mat, cuivre mat.

Estructura: florón blanco – cerámica y partes metálicas en los colores: blanco mate, negro mate, oro mate, cobre mate.

Структура: белый розон, керамические и металлические части в цветах: матовый белый, матовый чёрный, матовый золотой, матовый медный.

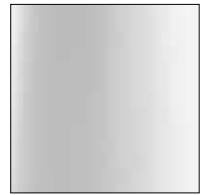

06: Bianco opaco/
Matt White



07: Nero opaco/
Matt Black



22: Oro opaco/
Matt Gold



29: Rame opaco/
Matt copper



10
3,93"

RAMETTO SO S/R

1 x 5,5W E14 LED

Consigliata/Recommend
Ledluster Philips



2,8
1,10"

RAMETTO BA

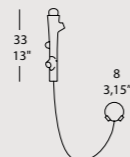

12,5
4,9"

RAMETTO PA1

1 x 5,5W E14 LED

Consigliata/Recommend
Ledluster Philips

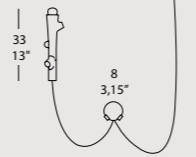

12,5
4,9"

RAMETTO PA2

2 x 5,5W E14 LED

Consigliata/Recommend
Ledluster Philips

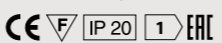

ROSONI/CANOPIES

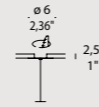

12
4,73"

RAMETTO IN-1
ROSONE A 1 LUCE
1-LIGHT RECESSED CANOPY



13
5,11"

RAMETTO RO-1
ROSONE A 1 LUCE
1-LIGHT CANOPY

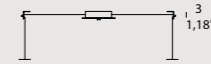

15
5,9"

RAMETTO RO-2
ROSONE A 2 LUCI
2-LIGHT CANOPY

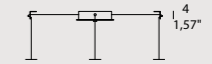

17
6,69"

RAMETTO RO-3
ROSONE A 3 LUCI
3-LIGHT CANOPY

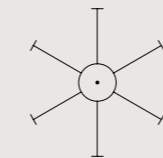
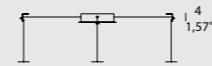

17
6,69"

RAMETTO RO-6
ROSONE A 6 LUCI
6-LIGHT CANOPY

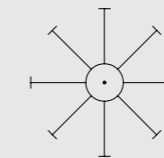
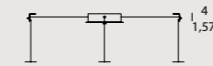

17
6,69"

RAMETTO RO-8
ROSONE A 8 LUCI
8-LIGHT CANOPY

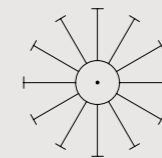
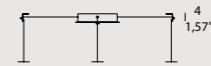

20
7,87"

RAMETTO RO-12
ROSONE A 12 LUCI
12-LIGHT CANOPY



ESEMPI DI COMPOSIZIONE/EXAMPLES OF COMPOSITION

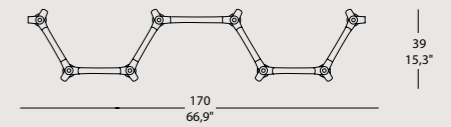
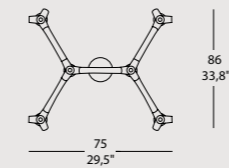
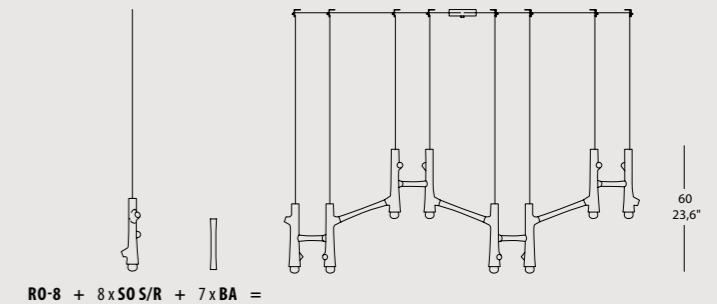
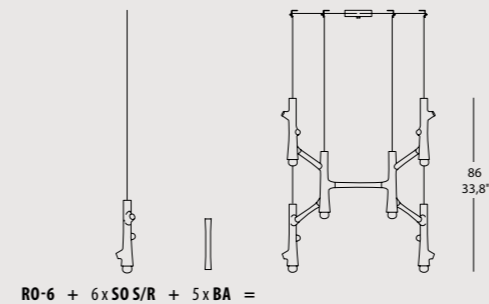



MIKADO



Filippo Mambretti



**1° PREMIO
WINNER**

Intreccio di segni evocativo
come un ideogramma.

An evocative weave of signs,
like an ideogram.



Riletture in chiave destrutturata dell'estetica classica dei lampadari a sospensione. Mikado è un intreccio di linee e piani che producono un fluttuante movimento nello spazio generando figure geometriche semplici o complesse.

Le varie versioni a sospensione, lineari o circolari, permettono diversi gradi di personalizzazione ed elaborazione della struttura: sobria e minimalista o complessa ed eccentrica grazie alla sovrapposizione di piani ad altezze asimmetriche.

Le sorgenti a LED sono racchiuse in particolari metallici di forma conica, disponibili anche con diffusore in vetro soffiato satinato che impreziosisce ulteriormente la collezione.

Relecture sous un jour déstructuré de l'esthétique classique des lustres à suspension. Mikado est un enchevêtrement de lignes et de plans qui produisent un mouvement fluctuant dans l'espace générant des figures géométriques simples ou complexes.

Les différentes versions à suspension, linéaires ou circulaires, permettent différents degrés de personnalisation et d'élaboration de la structure : sobre et minimaliste ou complexe et excentrique grâce à la superposition de plans à des hauteurs asymétriques.

Les sources à LED sont contenues dans des éléments métalliques de forme conique, également fournis avec un diffuseur en verre soufflé satiné qui enrichit ultérieurement la collection.

AGGIORNAMENTO DATI TECNICI/ UPGRADE TECHNICAL DATA

A deconstructive reinterpretation of the classical aesthetics of pendant chandeliers. Mikado is a mixture of lines and planes that produce a fluctuating movement in space creating simple or complex geometric figures.

The various linear or circular pendant versions allow different degrees of customization and elaboration of the frame: simple and minimalist or complex and eccentric thanks to the overlapping planes at asymmetric heights. The LED sources are enclosed inside of conical metallic elements, available also with satin blown glass diffuser, further enriching the collection.

Relectura en clave descompuesta de la estética clásica de las lucernas suspendidas, Mikado es un enredo de líneas y planos que producen un movimiento oscilante en el espacio generando figuras geométricas simples y complejas.

Las varias versiones a suspensión, lineales o circulares, permiten varios grados de personalización y elaboración de la estructura: sobria y minimalista o compleja y excéntrica gracias a la sobreposición de planos de alturas asimétricas.

Las fuentes de LED están encerradas en detalles metálicos de forma cónica, disponibles incluso con difusor de vidrio soplado satinado que valoriza ulteriormente la colección.

Eine unstrukturierte Neuinterpretation der klassischen Ästhetik von Hängelampen. Mikado ist ein Geflecht aus Linien und Ebenen das schwankende Bewegungen im Raum produziert, indem es einfache und komplexe Geometrie-Figuren erzeugt. Die verschiedenen Ausführungen der Abhängungen, linear oder kreisförmig, ermöglichen diverse Möglichkeiten der Personalisierung und Ausarbeitung der Struktur: schlicht und minimalistisch, oder komplex und exzentrisch, dank der Überlappung der Ebenen in asymmetrischen Abständen. Die LED-Lichtquellen sind eingeschlossen in metallische Teile mit konischer Form. Erhältlich auch mit Diffusor aus satiniertem und geblasenen Glas, das die Kollektion nochmals erheblich aufwertet.

Новая интерпретация в деструктивном ключе классической эстетики подвесных светильников.

Микато — это переплетение линий и плоскостей, которые вызывает колеблющееся движение в пространстве, создавая простые и сложные геометрические фигуры.

Разнообразные версии подвешиванием, позволяют разную степень персонализации и отделки структуры: строгую и минималистичную или, благодаря асимметричному расположению плоскостей по высоте, сложную и эксцентричную. Источники LED заключены в металлические элементы конической формы, которые также могут быть предложены с рассеивателем из дутого сатинированного стекла, придающего коллекции дополнительную ценность.

Struttura: metallo nero opaco.

Frame: matt black metal.

Struktur: Metall, mattschwarz.

Structure: métal noir mat.

Estructura: metal negro opaco.

Структура: металл, выполняется в черном матовом цвете.

Diffusore: vetro satinato.

Diffuser: satin glass.

Diffusor: Satiniertes Glas.

Diffuseur: verre satiné.

Difusor: vidrio satinado.

Рассеиватель: Сатинированное стекло.

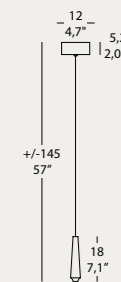

MIKADO S0 1 GLASS_S

1 x 3,2W 355 Lm 3000K Cri>80 220/240V

1 x 3,2W 335 Lm 2700K Cri>80 220/240V **LED**

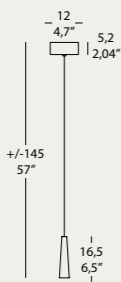
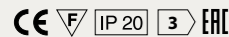

MIKADO S0 1_S

1 x 3,2W 355 Lm 3000K Cri>80 220/240V

1 x 3,2W 335 Lm 2700K Cri>80 220/240V **LED**



MIKADO S0 1 GLASS_L

1 x 3,2W 355 Lm 3000K Cri>80 220/240V

1 x 3,2W 335 Lm 2700K Cri>80 220/240V **LED**

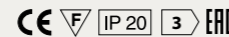

MIKADO S0 1_L

1 x 3,2W 355 Lm 3000K Cri>80 220/240V

1 x 3,2W 335 Lm 2700K Cri>80 220/240V **LED**

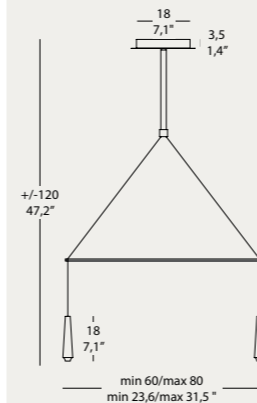

MIKADO S2L GLASS_S

2 x 3,2W 710 Lm 3000K Cri>80 220/240V

2 x 3,2W 670 Lm 2700K Cri>80 220/240V **LED**

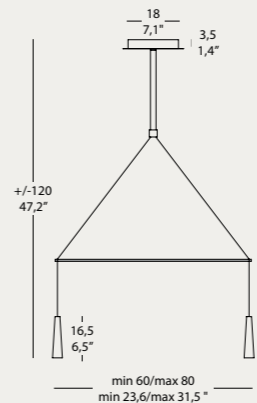
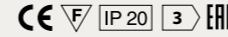

MIKADO S2L_S

2 x 3,2W 710 Lm 3000K Cri>80 220/240V

2 x 3,2W 670 Lm 2700K Cri>80 220/240V **LED**

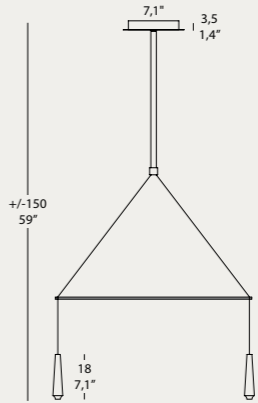
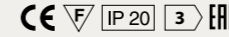

MIKADO S2L GLASS_L

2 x 3,2W 710 Lm 3000K Cri>80 220/240V

2 x 3,2W 670 Lm 2700K Cri>80 220/240V **LED**

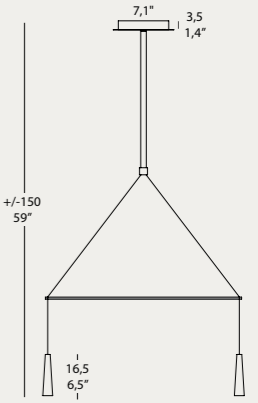
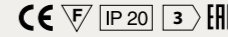

MIKADO S2L_L

2 x 3,2W 710 Lm 3000K Cri>80 220/240V

2 x 3,2W 670 Lm 2700K Cri>80 220/240V **LED**

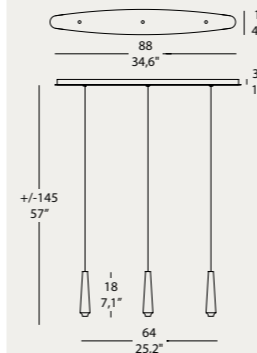
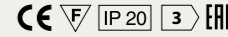

MIKADO S3L GLASS_S

3 x 3,2W 1065 Lm 3000K Cri>80 220/240V

3 x 3,2W 1005 Lm 2700K Cri>80 220/240V **LED**

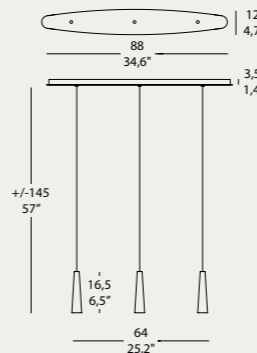
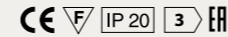

MIKADO S3L_S

3 x 3,2W 1065 Lm 3000K Cri>80 220/240V

3 x 3,2W 1005 Lm 2700K Cri>80 220/240V **LED**

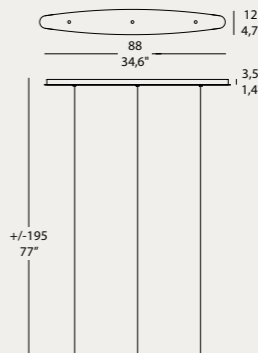
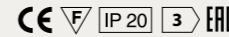

MIKADO S3L GLASS_L

3 x 3,2W 1065 Lm 3000K Cri>80 220/240V

3 x 3,2W 1005 Lm 2700K Cri>80 220/240V **LED**

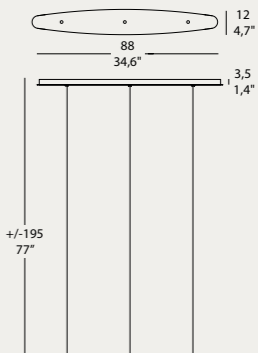
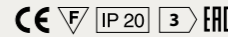

MIKADO S3L_L

3 x 3,2W 1065 Lm 3000K Cri>80 220/240V

3 x 3,2W 1005 Lm 2700K Cri>80 220/240V **LED**

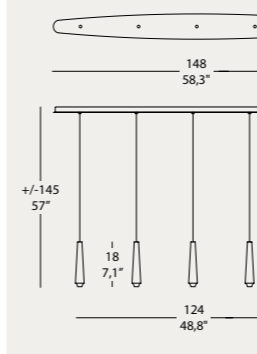
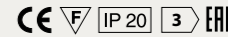

MIKADO SSL GLASS_S

5 x 3,2W 1775 Lm 3000K Cri>80 220/240V

5 x 3,2W 1675 Lm 2700K Cri>80 220/240V **LED**

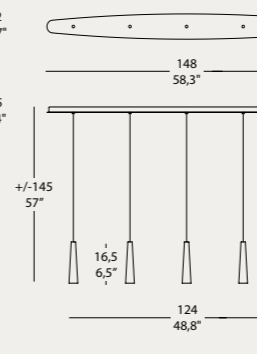
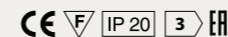

MIKADO SSL_S

5 x 3,2W 1775 Lm 3000K Cri>80 220/240V

5 x 3,2W 1675 Lm 2700K Cri>80 220/240V **LED**

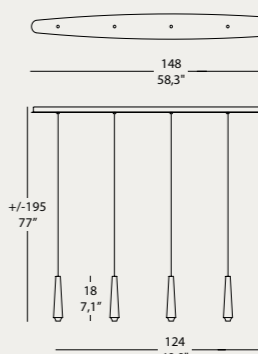
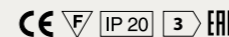

MIKADO SSL GLASS_L

5 x 3,2W 1775 Lm 3000K Cri>80 220/240V

5 x 3,2W 1675 Lm 2700K Cri>80 220/240V **LED**

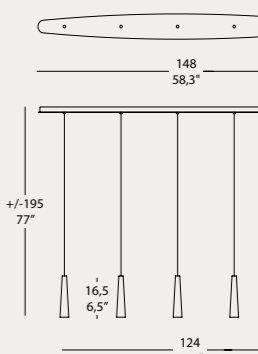
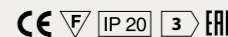

MIKADO SSL_L

5 x 3,2W 1775 Lm 3000K Cri>80 220/240V

5 x 3,2W 1675 Lm 2700K Cri>80 220/240V **LED**



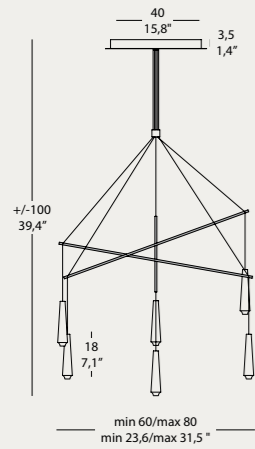

MIKADO LA 6 GLASS_S

6 x 3,2W 2130 Lm 3000K Cri>80 220/240V
6 x 3,2W 2010 Lm 2700K Cri>80 220/240V **LED**

MIKADO LA 6 GLASS_S DIM PD

6 x 3,2W 2130 Lm 3000K Cri>80 220/240V
6 x 3,2W 2010 Lm 2700K Cri>80 220/240V
con driver dimmerabile push/with push dimmable driver 220/240V **LED**

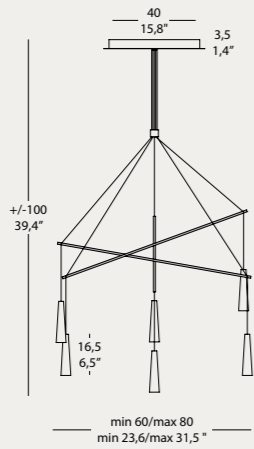
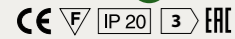

MIKADO LA 6_S

6 x 3,2W 2130 Lm 3000K Cri>80 220/240V
6 x 3,2W 2010 Lm 2700K Cri>80 220/240V **LED**

MIKADO LA 6_S DIM PD

6 x 3,2W 2130 Lm 3000K Cri>80 220/240V
6 x 3,2W 2010 Lm 2700K Cri>80 220/240V
con driver dimmerabile push/with push dimmable driver 220/240V **LED**

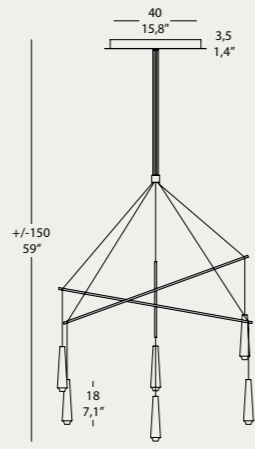
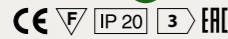

MIKADO LA 6 GLASS_L

6 x 3,2W 2130 Lm 3000K Cri>80 220/240V
6 x 3,2W 2010 Lm 2700K Cri>80 220/240V **LED**

MIKADO LA 6 GLASS_L DIM PD

6 x 3,2W 2130 Lm 3000K Cri>80 220/240V
6 x 3,2W 2010 Lm 2700K Cri>80 220/240V
con driver dimmerabile push/with push dimmable driver 220/240V **LED**

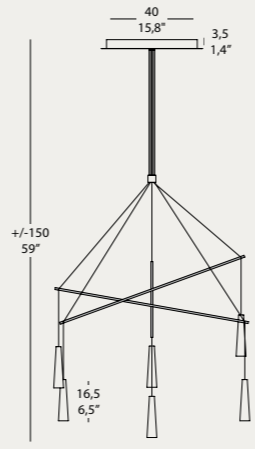
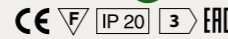

MIKADO LA 6_L

6 x 3,2W 2130 Lm 3000K Cri>80 220/240V
6 x 3,2W 2010 Lm 2700K Cri>80 220/240V **LED**

MIKADO LA 6_L DIM PD

6 x 3,2W 2130 Lm 3000K Cri>80 220/240V
6 x 3,2W 2010 Lm 2700K Cri>80 220/240V
con driver dimmerabile push/with push dimmable driver 220/240V **LED**

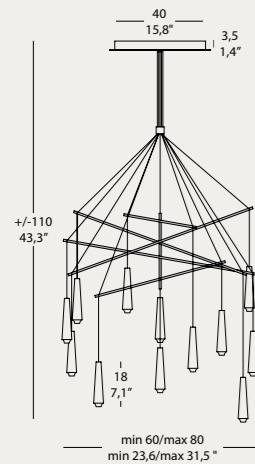
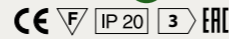

MIKADO LA 12 GLASS_S

12 x 3,2W 4260 Lm 3000K Cri>80 220/240V
12 x 3,2W 4020 Lm 2700K Cri>80 220/240V **LED**

MIKADO LA 12 GLASS_S DIM PD

12 x 3,2W 4260 Lm 3000K Cri>80 220/240V
12 x 3,2W 4020 Lm 2700K Cri>80 220/240V
con driver dimmerabile push/with push dimmable driver 220/240V **LED**

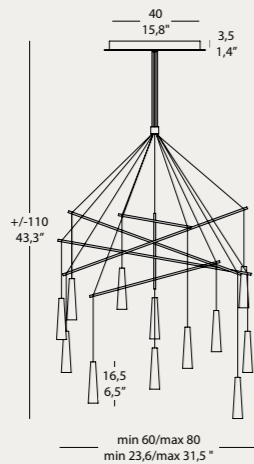
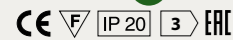

MIKADO LA 12_S

12 x 3,2W 4260 Lm 3000K Cri>80 220/240V
12 x 3,2W 4020 Lm 2700K Cri>80 220/240V **LED**

MIKADO LA 12_S DIM PD

12 x 3,2W 4260 Lm 3000K Cri>80 220/240V
12 x 3,2W 4020 Lm 2700K Cri>80 220/240V
con driver dimmerabile push/with push dimmable driver 220/240V **LED**

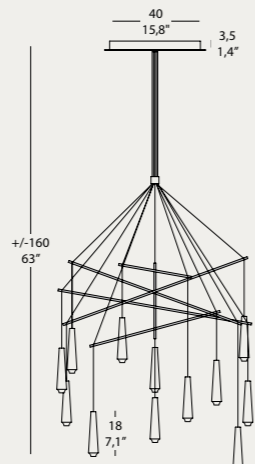

MIKADO LA 12 GLASS_L

12 x 3,2W 4260 Lm 3000K Cri>80 220/240V
12 x 3,2W 4020 Lm 2700K Cri>80 220/240V **LED**

MIKADO LA 12 GLASS_L DIM PD

12 x 3,2W 4260 Lm 3000K Cri>80 220/240V
12 x 3,2W 4020 Lm 2700K Cri>80 220/240V
con driver dimmerabile push/with push dimmable driver 220/240V **LED**

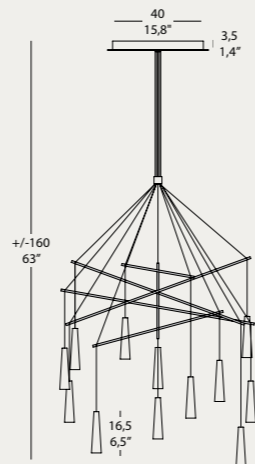

MIKADO LA 12_L

12 x 3,2W 4260 Lm 3000K Cri>80 220/240V
12 x 3,2W 4020 Lm 2700K Cri>80 220/240V **LED**

MIKADO LA 12_L DIM PD

12 x 3,2W 4260 Lm 3000K Cri>80 220/240V
12 x 3,2W 4020 Lm 2700K Cri>80 220/240V
con driver dimmerabile push/with push dimmable driver 220/240V **LED**

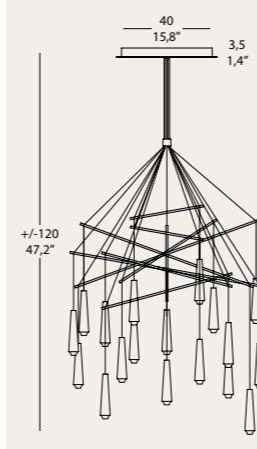
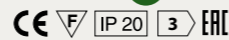

MIKADO LA 18 GLASS_S

18 x 3,2W 6390 Lm 3000K Cri>80 220/240V
18 x 3,2W 6030 Lm 2700K Cri>80 220/240V **LED**

MIKADO LA 18 GLASS_S DIM PD

18 x 3,2W 6390 Lm 3000K Cri>80 220/240V
18 x 3,2W 6030 Lm 2700K Cri>80 220/240V
con driver dimmerabile push/with push dimmable driver 220/240V **LED**

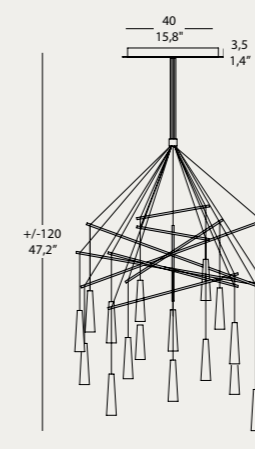
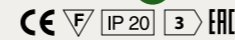

MIKADO LA 18_S

18 x 3,2W 6390 Lm 3000K Cri>80 220/240V
18 x 3,2W 6030 Lm 2700K Cri>80 220/240V **LED**

MIKADO LA 18_S DIM PD

18 x 3,2W 6390 Lm 3000K Cri>80 220/240V
18 x 3,2W 6030 Lm 2700K Cri>80 220/240V
con driver dimmerabile push/with push dimmable driver 220/240V **LED**

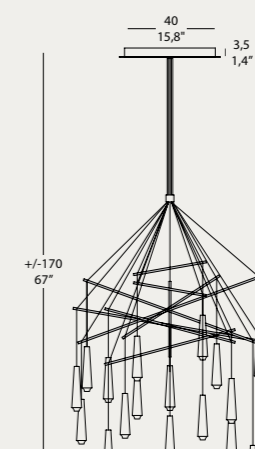
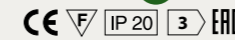

MIKADO LA 18 GLASS_L

18 x 3,2W 6390 Lm 3000K Cri>80 220/240V
18 x 3,2W 6030 Lm 2700K Cri>80 220/240V **LED**

MIKADO LA 18 GLASS_L DIM PD

18 x 3,2W 6390 Lm 3000K Cri>80 220/240V
18 x 3,2W 6030 Lm 2700K Cri>80 220/240V
con driver dimmerabile push/with push dimmable driver 220/240V **LED**

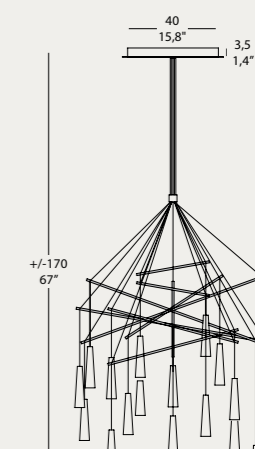
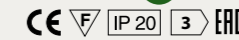

MIKADO LA 18_L

18 x 3,2W 6390 Lm 3000K Cri>80 220/240V
18 x 3,2W 6030 Lm 2700K Cri>80 220/240V **LED**

MIKADO LA 18_L DIM PD

18 x 3,2W 6390 Lm 3000K Cri>80 220/240V
18 x 3,2W 6030 Lm 2700K Cri>80 220/240V
con driver dimmerabile push/with push dimmable driver 220/240V **LED**



**SU RICHIESTA È POSSIBILE AVERE ANCHE DRIVER DIMMERABILE 1/10V
1/10V DIMMABLE DRIVER CAN BE SUPPLIED BY REQUEST**

**BARRA/BAR 50
NERO/BLACK**

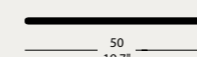

**BARRA/BAR 75
NERO/BLACK**

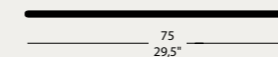

DIFFUSORE/DIFFUSER

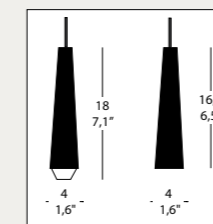



SANTRAL

•
Filippo Mambretti

Moderna, morbida, modulare.
Modern, smooth, modular.



- Modello Europeo Registrato
- European Registered Design

Santral rivoluziona l'estetica classica dei lampadari a sospensione. La collezione è altamente personalizzabile nel design grazie ai cavi indipendenti con i quali è possibile creare infinite composizioni sia all'interno dello spazio circoscritto del rosone, sia liberamente all'esterno per mezzo di ancoraggi fissati al soffitto.

Si ottiene così un oggetto d'arredo capace di caratterizzare con formalità e assoluta originalità sia location circoscritte che ambienti spaziosi. Di facile installazione grazie ad un sistema di jack, Santral prevede sorgenti a LED racchiuse in particolari metallici di forma conica, disponibili anche con diffusore in vetro soffiato satinato che impreziosisce ulteriormente la collezione.

Santral bouleverse l'esthétique classique des lustres à suspension. La collection est hautement personnalisable au niveau du design grâce aux câbles indépendants avec lesquels on peut créer d'infinies compositions à l'intérieur de l'espace circonscrit de la plaque ronde, et librement à l'extérieur au moyen d'ancrages fixés au plafond.

On obtient ainsi un objet de décoration capable de caractériser avec une formalité et une originalité absolue des espaces circonscrits et des pièces spacieuses.

Facile à installer grâce à un système de jacks, Santral prévoit des sources à LED contenues dans des éléments métalliques de forme conique, également fournis avec un diffuseur en verre soufflé satiné qui enrichit ultérieurement la collection.

AGGIORNAMENTO DATI TECNICI/ UPGRADE TECHNICAL DATA

Santral revolutionizes the classic aesthetics of pendant chandeliers. The collection is highly customizable in design thanks to independent cables with which you can create endless compositions within the ceiling rose of the lamp, but also outside of it, through anchors that are fixed to the ceiling.

The result is a piece of furniture able to give formality and absolute originality to small locations but also to big spaces. Thanks to a system of jacks, Santral is easy to be installed and provides LED sources which are inside of conical metallic elements, also available with a diffuser in blown glass that further enhances the collection.

Santral revoluciona la estética clásica de las arañas.

La colección es perfectamente personalizable en el design gracias a los cables independientes con los cuales es posible crear infinitas composiciones tanto en el interior del espacio circunscrito del rosetón como libremente en el exterior por medio de anclajes fijados al techo.

Se obtiene así un objeto de decoración en condiciones de caracterizar con formalidad y absoluta originalidad tanto lugares circunscritos como ambientes espaciosos.

De fácil instalación gracias a un sistema de jack, Santral prevé fuentes de LED encerradas en detalles metálicos de forma cónica, disponibles incluso con difusor de vidrio soplado satinado que valoriza ulteriormente la colección.

Santral revolutioniert die klassische Ästhetik der Hängelampen. Die Kollektion ist durch unabhängige Kabel vielseitig im Design personalisierbar. Mit diesen kann man unzählige Kompositionen erstellen, im engen Inneren der Rosette, aber auch bequem aussen durch Deckenbefestigungen. Dadurch entsteht ein Einrichtungsgegenstand, der durch seine Formalität und absolute Originalität in engen Räumen, wie auch geräumigen Umgebungen besticht. Mit einem einfachen Buchsen-Montagesystem ausgestattet, sieht Santral LED-Lichtquellen vor, die in metallische Teile mit konischer Form eingeschlossen sind. Erhältlich auch mit Diffusor aus satiniertem und geblasenen Glas, das die Kollektion nochmals erheblich aufwertet.

Santral производит коренной переворот в классической эстетике подвесных светильников. Коллекция обладает большими возможностями персонализации дизайна, благодаря отдельным проводам, с помощью которых возможно создать бесконечное множество композиций, как внутри пространства, ограниченного потолочной чашей, так и снаружи с помощью потолочных анкеров.

Таким образом, создается предмет обстановки, способный охарактеризовать формально и с абсолютной оригинальностью как ограниченные пространства, так и просторные помещения.

Легко монтируется благодаря системе jack, Santral предусматривает источники света LED, заключенные в металлические элементы конической формы, которые также могут быть предложены с рассеивателем из дутого сатинированного стекла, придающего коллекции дополнительную ценность.

Struttura: metallo nero opaco.
Diffusore: vetro satinato.

Frame: matt black metal.
Diffuser: satin glass.

Struktur: Metall, mattschwarz.
Diffusor: Satiniertes Glas.

Structure: métal noir mat.
Diffuseur: verre satiné.

Estructura: metal negro opaco.
Difusor: vidrio satinado.

Структура: металл, выполняется в черном матовом цвете.
Рассеиватель: Сатинированное стекло.

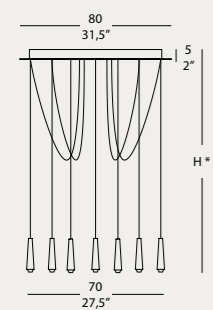

SANTRAL LA 8 GLASS_S
Cavo/cable standard cm 200/78,8"

8 x 3,2W 2840 Lm 3000K Cri>80 220/240V
8 x 3,2W 2680 Lm 2700K Cri>80 220/240V **LED**

SANTRAL LA 8 GLASS_S DIM PD

8 x 3,2W 2840 Lm 3000K Cri>80 220/240V
8 x 3,2W 2680 Lm 2700K Cri>80 220/240V

con driver dimmerabile push/with push dimmable driver 220/240V **LED**

CE **F** **IP 20** **3** **ERC**

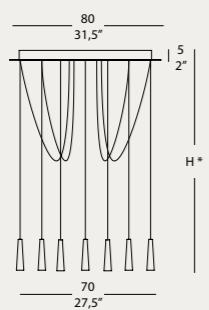

SANTRAL LA 8_S
Cavo/cable standard cm 200/78,8"

8 x 3,2W 2840 Lm 3000K Cri>80 220/240V
8 x 3,2W 2680 Lm 2700K Cri>80 220/240V **LED**

SANTRAL LA 8_S DIM PD

8 x 3,2W 2840 Lm 3000K Cri>80 220/240V
8 x 3,2W 2680 Lm 2700K Cri>80 220/240V

con driver dimmerabile push/with push dimmable driver 220/240V **LED**

CE **F** **IP 20** **3** **ERC**

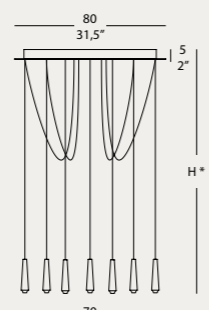

SANTRAL LA 8 GLASS_L
Cavo/cable standard cm 280/110,2"

8 x 3,2W 2840 Lm 3000K Cri>80 220/240V
8 x 3,2W 2680 Lm 2700K Cri>80 220/240V **LED**

SANTRAL LA 8 GLASS_L DIM PD

8 x 3,2W 2840 Lm 3000K Cri>80 220/240V
8 x 3,2W 2680 Lm 2700K Cri>80 220/240V

con driver dimmerabile push/with push dimmable driver 220/240V **LED**

CE **F** **IP 20** **3** **ERC**

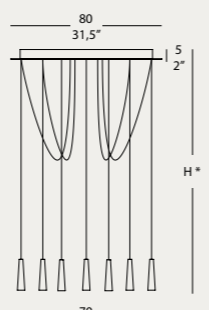

SANTRAL LA 8_L
Cavo/cable standard cm 280/110,2"

8 x 3,2W 2840 Lm 3000K Cri>80 220/240V
8 x 3,2W 2680 Lm 2700K Cri>80 220/240V **LED**

SANTRAL LA 8_L DIM PD

8 x 3,2W 2840 Lm 3000K Cri>80 220/240V
8 x 3,2W 2680 Lm 2700K Cri>80 220/240V

con driver dimmerabile push/with push dimmable driver 220/240V **LED**

CE **F** **IP 20** **3** **ERC**

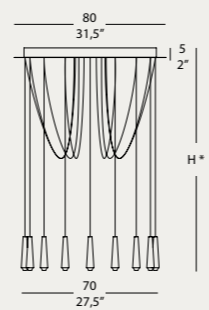

SANTRAL LA 16 GLASS_S
Cavo/cable standard cm 200/78,8"

16 x 3,2W 5680 Lm 3000K Cri>80 220/240V
16 x 3,2W 5360 Lm 2700K Cri>80 220/240V **LED**

SANTRAL LA 16 GLASS_S DIM PD

16 x 3,2W 5680 Lm 3000K Cri>80 220/240V
16 x 3,2W 5360 Lm 2700K Cri>80 220/240V

con driver dimmerabile push/with push dimmable driver 220/240V **LED**

CE **F** **IP 20** **3** **ERC**

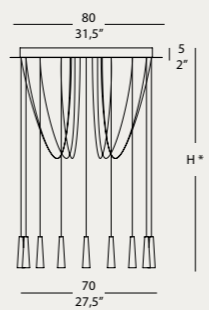

SANTRAL LA 16_S DIM PD
Cavo/cable standard cm 200/78,8"

16 x 3,2W 5680 Lm 3000K Cri>80 220/240V
16 x 3,2W 5360 Lm 2700K Cri>80 220/240V **LED**

SANTRAL LA 16_S DIM PD

16 x 3,2W 5680 Lm 3000K Cri>80 220/240V
16 x 3,2W 5360 Lm 2700K Cri>80 220/240V

con driver dimmerabile push/with push dimmable driver 220/240V **LED**

CE **F** **IP 20** **3** **ERC**

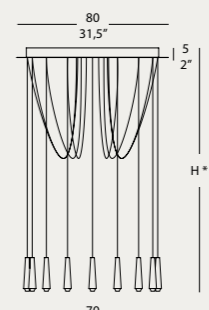

SANTRAL LA 16 GLASS_L
Cavo/cable standard cm 280/110,2"

16 x 3,2W 5680 Lm 3000K Cri>80 220/240V
16 x 3,2W 5360 Lm 2700K Cri>80 220/240V **LED**

SANTRAL LA 16 GLASS_L DIM PD

16 x 3,2W 5680 Lm 3000K Cri>80 220/240V
16 x 3,2W 5360 Lm 2700K Cri>80 220/240V

con driver dimmerabile push/with push dimmable driver 220/240V **LED**

CE **F** **IP 20** **3** **ERC**

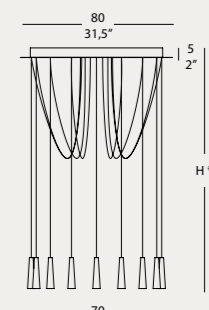

SANTRAL LA 16_L
Cavo/cable standard cm 280/110,2"

16 x 3,2W 5680 Lm 3000K Cri>80 220/240V
16 x 3,2W 5360 Lm 2700K Cri>80 220/240V **LED**

SANTRAL LA 16_L DIM PD

16 x 3,2W 5680 Lm 3000K Cri>80 220/240V
16 x 3,2W 5360 Lm 2700K Cri>80 220/240V

con driver dimmerabile push/with push dimmable driver 220/240V **LED**

CE **F** **IP 20** **3** **ERC**

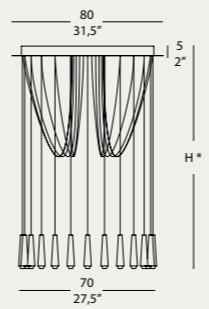

SANTRAL LA 24 GLASS_S
Cavo/cable standard cm 200/78,8"

24 x 3,2W 8520 Lm 3000K Cri>80 220/240V
24 x 3,2W 8040 Lm 2700K Cri>80 220/240V **LED**

SANTRAL LA 24 GLASS_S DIM PD

24 x 3,2W 8520 Lm 3000K Cri>80 220/240V
24 x 3,2W 8040 Lm 2700K Cri>80 220/240V

con driver dimmerabile push/with push dimmable driver 220/240V **LED**

CE **F** **IP 20** **3** **ERC**

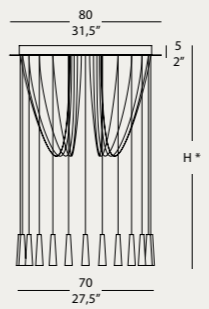

SANTRAL LA 24_S
Cavo/cable standard cm 200/78,8"

24 x 3,2W 8520 Lm 3000K Cri>80 220/240V
24 x 3,2W 8040 Lm 2700K Cri>80 220/240V **LED**

SANTRAL LA 24_S DIM PD

24 x 3,2W 8520 Lm 3000K Cri>80 220/240V
24 x 3,2W 8040 Lm 2700K Cri>80 220/240V

con driver dimmerabile push/with push dimmable driver 220/240V **LED**

CE **F** **IP 20** **3** **ERC**

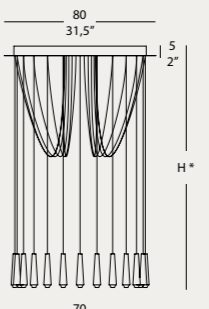

SANTRAL LA 24 GLASS_L
Cavo/cable standard cm 280/110,2"

24 x 3,2W 8520 Lm 3000K Cri>80 220/240V
24 x 3,2W 8040 Lm 2700K Cri>80 220/240V **LED**

SANTRAL LA 24 GLASS_L DIM PD

24 x 3,2W 8520 Lm 3000K Cri>80 220/240V
24 x 3,2W 8040 Lm 2700K Cri>80 220/240V

con driver dimmerabile push/with push dimmable driver 220/240V **LED**

CE **F** **IP 20** **3** **ERC**

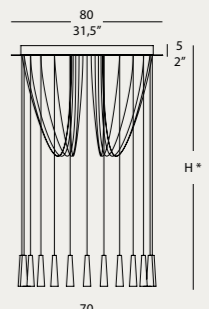

SANTRAL LA 24_L
Cavo/cable standard cm 280/110,2"

24 x 3,2W 8520 Lm 3000K Cri>80 220/240V
24 x 3,2W 8040 Lm 2700K Cri>80 220/240V **LED**

SANTRAL LA 24_L DIM PD

24 x 3,2W 8520 Lm 3000K Cri>80 220/240V
24 x 3,2W 8040 Lm 2700K Cri>80 220/240V

con driver dimmerabile push/with push dimmable driver 220/240V **LED**

CE **F** **IP 20** **3** **ERC**

H *
Altezza variabile/Variable height
Höhenverstellbar/Hauteur variable
Altura variable/меняющаяся высота

SU RICHIESTA È POSSIBILE AVERE ANCHE DRIVER DIMMERABILE 1/10V O DALI 1/10V AND DALI DIMMABLE DRIVER CAN BE SUPPLIED BY REQUEST



CUEVA

•

Filippo Mambretti



prodotto selezionato
selected product

Pura poesia estetica.
Pure aesthetic poetry.

Cueva è una collezione di lampade a sospensione dal design essenziale quanto ricercato, la prova che si può ottenere pulizia formale anche nella complessità.

L'illuminazione prodotta da sorgenti LED, a contatto con fogli di alluminio minuziosamente sovrapposti, arricchisce di ammalianti chiaroscuri le composizioni geometriche racchiuse all'interno della lampada, e filtrando all'esterno assicura un design sobrio ed essenziale. Da qualunque prospettiva la si guardi, Cueva è pura poesia estetica.

Cueva est une collection de lampes à suspension au design aussi essentiel que raffiné, prouvant que l'on peut également obtenir une netteté formelle dans la complexité.

L'éclairage produit par les sources LED, au contact de feuilles d'aluminium minutieusement superposées, enrichit les compositions géométriques contenues dans la lampe de clairs-obscurs envoûtants, et il assure, en filtrant à l'extérieur, un design sobre et essentiel. Dans toute perspective, Cueva est une pure poésie esthétique.

Cueva is a collection of pendant lamps with an essential but at the same time sophisticated design, proof that you can get clean lines also in complexity. The light produced by LED sources and the carefully overlapping aluminium foils enrich the geometric compositions inside the lamp with a fascinating chiaroscuro, and, filtering from the outside, the light ensures a simple and essential design. From whatever perspective you look at it from, Cueva is pure aesthetic poetry.

Cueva es una colección de lámparas de suspensión de design esencial y rebuscado, la prueba de que se puede obtener esencialidad formal también en la complejidad.

La iluminación producida por fuentes LED, en contacto con hojas de aluminio minuciosamente superpuestas, enriquece de cautivantes claroscuros las composiciones geométricas encerradas en el interior de la lámpara y filtrando en el exterior asegura un design sobrio y esencial. Desde cualquier perspectiva se vea, Cueva es pura poesía estética.

Cueva ist eine Lampenkollektion mit Abhängung und gewollt einfachem Design. Der Beweis dafür, dass klare Linien auch in der Komplexität entstehen können. Die Ausleuchtung die durch die LED-Lichtquellen erzeugt werden, die wiederum im Kontakt mit den präzise übereinander gelegten Aluminiumstreifen stehen, bereichert mit bezaubernden Hell-Dunkel Kontrasten die geometrischen Kompositionen die im Inneren der Lampe eingeschlossen sind und aussen filtrieren. Ein essenzielles und schlichtes Design. Aus welcher Perspektive man sie auch betrachtet, Cueva ist reine und ästhetische Pose.

Cueva – коллекция подвесных светильников простого и в то же время изысканного дизайна, подтверждение того, что возможно добиться определенной чистоты даже в сложности.

Свет, полученный при помощи источников LED, в контакте с алюминиевыми листами, наложенными друг на друга, обогащает завораживающей игрой светотеней геометрические композиции, заключенные внутри светильника, и, фильтруя с внешней стороны, обеспечивает простой и строгий дизайн. Cueva - это чистая изящная поэзия, с какой бы стороны на нее не посмотреть.

Struttura: metallo bianco opaco. **Frame:** matt white metal.
Diffusore: policarbonato opalino. **Diffuser:** opal polycarbonate.

Struktur: Metall mattweiß. **Structure:** métal blanc mat.
Diffusor: Polycarbonat opalartig. **Diffuseur:** polycarbonate opalin.

Estructura: metal blanco opaco. **Структура:** белый матовый металл.
Difusor: policarbonato opalescente. **Рассеиватель:** Поликарбонат опалового цвета.

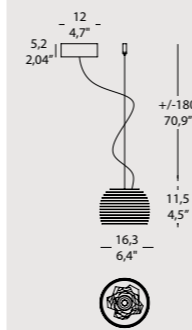

CUEVA SO 16

9,1W 1230 Lm 3000K Cri>80 220/240V

9,1W 1180 Lm 2700K Cri>80 220/240V **LED**

CUEVA SO 16 DIM PD

9,1W 1230 Lm 3000K Cri>80 220/240V

9,1W 1180 Lm 2700K Cri>80 220/240V

Con driver dimmerabile push/with push dimmable driver 220/240V **LED**

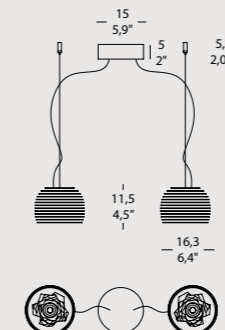

CUEVA SO 16/2

18,2W 2460 Lm 3000K Cri>80 220/240V

18,2W 2360 Lm 2700K Cri>80 220/240V **LED**

CUEVA SO 16/2 DIM PD

18,2W 2460 Lm 3000K Cri>80 220/240V

18,2W 2360 Lm 2700K Cri>80 220/240V

Con driver dimmerabile push/with push dimmable driver 220/240V **LED**

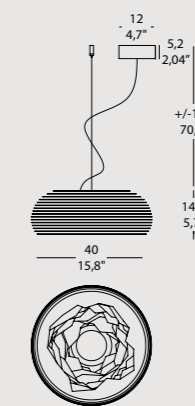
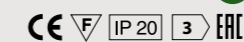

CUEVA SO 40

14,4W 1730 Lm 3000K Cri>80 220/240V

14,4W 1665 Lm 2700K Cri>80 220/240V **LED**

CUEVA SO 40 DIM PD

14,4W 1730 Lm 3000K Cri>80 220/240V

14,4W 1665 Lm 2700K Cri>80 220/240V

Con driver dimmerabile push/with push dimmable driver 220/240V **LED**

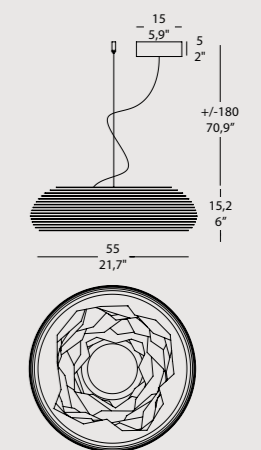
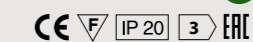

CUEVA SO 55

27,3W 3690 Lm 3000K Cri>80 220/240V

27,3W 3540 Lm 2700K Cri>80 220/240V **LED**

CUEVA SO 55 DIM PD

27,3W 3690 Lm 3000K Cri>80 220/240V

27,3W 3540 Lm 2700K Cri>80 220/240V

Con driver dimmerabile push/with push dimmable driver 220/240V **LED**

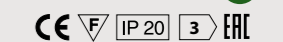

SU RICHIESTA È POSSIBILE AVERE ANCHE DRIVER DIMMERABILE 1/10V
1/10V DIMMABLE DRIVER CAN BE SUPPLIED BY REQUEST



PANK



Tiziano Maffione

Un taglio decisamente
particolare.

Definitely a peculiar cut.

AGGIORNAMENTO DATI TECNICI/ UPGRADE TECHNICAL DATA

Un semplice taglio obliquo su una struttura cilindrica. Questa è Pank. Un'idea essenziale, ma capace di riassumere e di condensare tutta la creatività e l'ingegno del design dell'illuminazione. Pank è dinamicità. Grazie alla sua particolare linea, la forma della lampada muta a seconda del punto di vista, trasmettendo movimento a tutto l'arredamento. Pank è estro. Le molteplici dimensioni e combinazioni cromatiche, con i loro contrasti tra interno ed esterno, sono un invito a giocare con i colori e con l'arredamento. Permettono inoltre alla lampada di adattarsi facilmente sia allo stile moderno e giovane che a quello più elegante e classico. Pank è versatilità. La vasta gamma di versioni permette alla collezione di dimostrarsi la soluzione perfetta per diverse esigenze di spazio e arredamento, oltre che di illuminazione. Il fascio luminoso può essere infatti indirizzato in base alla necessità di luce o d'atmosfera. Pank è eccellenza. La scelta dei materiali, tra cui il tessuto a tramatura evidente, così come la cura di fabbricazione, testimoniano l'attenzione alla qualità e all'esperienza sensoriale, che rappresentano il segno distintivo del brand Morosini.

Une simple coupe oblique sur une structure cylindrique. C'est la lampe Pank. Une idée essentielle mais capable de résumer et de condenser toute la créativité et le génie du design de l'éclairage. Pank est synonyme de dynamisme. Grâce à sa ligne particulière, la forme de la lampe se transforme en fonction du point de vue, transmettant du mouvement à toute la décoration. Pank est synonyme d'inspiration. De nombreuses dimensions et combinaisons chromatiques, avec leurs contrastes entre l'intérieur et l'extérieur, sont une invitation à jouer avec les couleurs et avec la décoration. Elle permet également à la lampe de s'adapter facilement à un style moderne et jeune et à un style plus élégant et classique. Pank est synonyme de polyvalence. Grâce à la vaste gamme de versions, la collection est la solution parfaite pour différentes exigences d'espace et de décoration, au-delà de l'éclairage. Le faisceau lumineux peut en effet être orienté en fonction de la lumière ou de l'atmosphère souhaitée. Pank est synonyme d'excellence. Le choix des matériaux, comme le tissu à tramage évident, tout comme le soin de la fabrication, témoignent de l'attention portée à la qualité et à l'expérience sensorielle, qui représentent le signe distinctif de la marque Morosini.

A simple oblique cut on a cylindrical structure. This is Pank. An essential idea, able to summarize and concentrate all the creativity and brilliance of lighting design. Pank is dynamism. Thanks to its particular line, the shape of the lamp changes depending on the point of view, spreading movement to all the furniture. Pank is inspiration. The multiple sizes and color combinations, with their contrasts between inside and outside, are an invite to play with the colors and the furniture. It also allows the lamp to be easily adapted to both the young-modern and the more elegant and classic style. Pank is versatility. The wide range of versions allows the collection to be the perfect solution for different needs of space and furnishings, as well as for lighting needs. As a matter of fact, the beam of light can be moved according to the light and atmosphere you need. Pank is excellence. The choice of materials, such as the evident weave of the fabric, as well as the production care, shows the attention to the quality and to the sensory experience, which are the hallmark of Morosini brand.

Un simple corte oblicuo en una estructura cilíndrica. Esto es Pank. Una idea esencial pero en condiciones de resumir y condensar toda la creatividad y el ingenio del diseño de la iluminación. Pank es dinamismo. Gracias a su particular línea, la forma de la lámpara cambia según el punto de vista, transmitiendo movimiento a toda la decoración. Pank es estro. Las múltiples dimensiones y combinaciones cromáticas, con sus contrastes entre interior y exterior, son una invitación a jugar con los colores y con la decoración. Permiten además a la lámpara adaptarse fácilmente tanto al estilo moderno y juvenil como a la más elegante y clásica. Pank es versatilidad. La vasta gama de versiones permite a la colección demostrarse como la solución perfecta para varias exigencias de espacio y decoración, además que de iluminación. En efecto, el haz luminoso puede dirigirse sobre la base de las necesidades de luz o de atmósfera. Pank es excelencia. La selección de los materiales entre los cuales está el tejido de trama evidente, así como el cuidado en la fabricación, testimonian la atención a la calidad y a la experiencia sensorial, que representan el signo distintivo del brand Morosini.

Ein einfacher, schräger Schnitt auf einer zylindrischen Struktur. Das ist Pank. Eine essentielle Idee, die die ganze Kreativität und Intelligenz des Beleuchtungsdesigns zusammenfasst und kondensiert. Pank ist Dynamik. Dank ihrer besonderen Form ändert sich die Lampe je nach Betrachtungspunkt und verleiht der ganzen Einrichtung Bewegung. Pank ist Schwung. Die vielfältigen Dimensionen und Farbkombinationen mit ihren Kontrasten innen und außen sind eine Einladung, um mit den Farben und der Einrichtung zu spielen. Sie ermöglichen der Lampe außerdem, sich leicht dem modernen und jungen, aber auch dem eleganten und klassischen Stil anzupassen. Pank ist Vielseitigkeit. Das große Angebot an Ausführungen ermöglicht der Kollektion, sich als perfekte Lösung für verschiedene Raum-, Einrichtungs- und auch Beleuchtungsanforderungen anzubieten. Das Lichtbündel kann je nach Lichtbedarf oder gewünschter Atmosphäre ausgerichtet werden. Pank ist Spitzenqualität. Die Wahl der Materialien, darunter der Stoff mit dem klaren Muster, wie auch die akurate Herstellung zeugen von der Beachtung der Qualität und der sinnlichen Erfahrung, die das unterscheidende Merkmal des Markenzeichens Morosini sind.

Простое наклонное сечение цилиндрической структуры. Это Pank. Эссенциальная идея, способная сконцентрировать весь творческий потенциал и возможности светового дизайна. Pank – это динамичность. Благодаря своей особой линии, форма лампы, меняющиеся в зависимости от угла зрения, придает движение всему интерьеру. Pank – это вдохновение. Многообразные размеры и сочетания цветов с контрастом между внутренней и внешней сторонами – приглашение играть с цветом и соформлением интерьеров. Позволяют светильникам адаптироваться к любому интерьерному стилю, от самого молодежного и современного до истинно элегантного и классического. Pank – это многогранность. Широкая гамма версий позволяет коллекции превосходно удовлетворить как требования по освещению, так и требований к пространству и интерьеру. Световой лучок может быть направлен в зависимости от потребности в свете или атмосферы. Pank – это совершенство. Выбор материалов, среди которых ткань среди которых ткань с характерным переплетением, наряду с тщательным исполнением при изготовлении, свидетельствуют о внимании к качеству и о способности к восприятию, являющиеся отличительной чертой бренда Morosini.

Struttura: metallo bianco opaco. **Frame:** white matt metal. **Diffusore:** paralumi in tessuto "chINETTE" nella vasta gamma di colori indicata nella scheda tecnica. Ad esclusione del colore Tortora, test filo incandescente 850°.

Struktur: Metall mattweiß. **Diffusor:** Lampenschirme aus "Chinette"-Stoff in dem Farbangebot des technischen Datenblatts. Glühdrahtprüfung bei 850°C, außer taubengrau.

Estructura: metal blanco opaco. **Struttura:** металл, окрашенный в белый матовый цвет. **Рассеиватель:** абажуры из ткани "chINETTE" представлены в широкой цветовой гамме, указанной в спецификации. Испытание раскаленной проволокой при 850°C (за исключением бледно-коричневого цвета с сероватым оттенком).

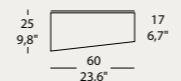

PANK PL 60 E - PL 60 E DIM
4 x MAX 18W 2G11 fluo **2**

PANK PL 60 E27
3 x MAX 52W E27 alo. **1**
o/or
3 x MAX 12W E27 LED

o/or **LED**

PANK PL 60 LED - PL 60 LED DIM *
26,7W 3720 Lm 3000K Cri> 80 220/240V **3**

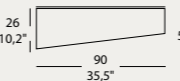

PANK PL 90 E - PL90 E DIM
4 x MAX 24W 2G11 fluo **2**

PANK PL 90 E27
6 x MAX 42W E27 alo. **1**
o/or
6 x MAX 12W E27 LED

o/or **LED**

PANK PL 90 LED - PL 90 LED DIM *
35,6W 5440 Lm 3000K Cri >80 220/240V **3**

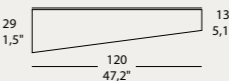

PANK PL 120 E - PL120 E DIM
4 x MAX 36W 2G11 fluo **2**

PANK PL 120 E27
6 x MAX 52W E27 alo. **1**
o/or
6 x MAX 12W E27 LED

o/or **LED**

PANK PL 120 LED - PL 120 LED DIM *
53,2W 7440 Lm 3000K Cri>80 220/240V **3**

DIM: Dimmerabile/Dimmable/Dimmbar Regulable/Диммирование

E: Ballast elettronico/Electronic ballast/ Elektronisches Vorschaltgerät/ Ballast électronique/Balasto electrónico/ Электронный балласт

* Con driver dimmerabile push With push dimmable driver

Su richiesta è possibile avere anche driver dimmerabile DALI DALI dimmable driver can be supplied by request



PANK PL 18
1 x MAX 12W E27 LED **1**

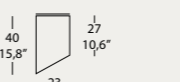

PANK PL 23
1 x MAX 70W E27 alo. **1**
o/or
1 x MAX 12W E27 LED

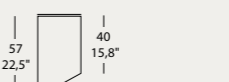

PANK PL 30
1 x MAX 105W E27 alo. **1**
o/or
1 x MAX 21W E27 LED



PANK PL 50
4 x MAX 42W E27 alo. **1**
o/or
4 x MAX 8W E27 LED



PANK S0 18
1 x MAX 12W E27 LED **1**



PANK S0 23
1 x MAX 70W E27 alo. **1**
o/or
1 x MAX 12W E27 LED

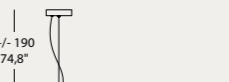

PANK S0 30
1 x MAX 105W E27 alo. **1**
o/or
1 x MAX 12W E27 LED

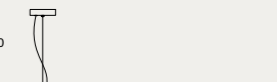

PANK S0 50
4 x MAX 42W E27 alo. **1**
o/or
4 x MAX 8W E27 LED



PANK TE
3 x MAX 70W E27 alo. **1**
o/or
3 x Max 14,5W E27 LED DIM

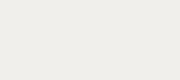

PANK TA
1 x MAX 70W E27 alo. **1**
o/or
1 x MAX 12W E27 LED

EviStyle[®]



trottola

•
Stefano Mandruzzato

Un girotondo di luce
che evoca un gioco
custodito nella memoria

A circle of light that evokes
a toy preserved
in the memory



Trottola_SO Medium



Trottola_SO Small



Trottola_SO Big



Trottola_SO 7 esempio di composizione _example of composition



Ispirata per nome e forma al secolare gioco per bambini, Trottola è una collezione di sospensioni in vetro soffiato composta da tre elementi dalla forte personalità.

Ironica, evocativa, giocosa, Trottola ci porta alla riscoperta della nostra infanzia. Disponibile in diverse soluzioni a sospensione, si presta sia per l'utilizzo domestico che per contract. La componente modulare permette innumerevoli combinazioni di customizzazione per soddisfare ogni esigenza del cliente. L'intera collezione utilizza sorgenti led dimmerabili.

Son nom et sa forme s'inspirent du jeu enfantin séculaire: Trottola est une collection de suspensions en verre soufflé constituée par trois éléments de caractère.

Ironique, évocatrice, gaie, Trottola nous mène à la découverte de notre enfance. Les différents modèles à suspension sont parfaits pour l'usage domestique et les collectivités. La composante modulaire permet d'innombrables combinaisons de personnalisation pour satisfaire toute exigence du client. Toute la collection utilise des sources led dimmables.

Inspired by the age-old game for children both in the name and shape, Trottola is a collection of three different blown glass suspensions with a strong personality.

Ironic, evocative, playful, Trottola brings us to the rediscovery of our childhood. Available in different suspension solutions, it is suitable both for private use and contract. The modular component allows countless combinations of customization to meet all customers' needs. The entire collection uses dimmable LED sources.

Trottola, cuyo nombre y forma se inspiran al antiguo juguete de la peonza, es una colección de colgantes de vidrio soplado que se compone por tres elementos con una personalidad fuerte.

Irónica, evocadora, jocosa, Trottola nos lleva a redescubrir nuestra infancia. Es disponible en diferentes opciones de colgante y se presta tanto al uso doméstico como al contract. El componente modular permite múltiples combinaciones para satisfacer la necesidad de customización de cada cliente. Toda la colección emplea fuentes led regulables.

Trottola hat sich von Namen und Form dieses Spiels inspirieren lassen. Trottola ist eine aus geblasenem Glas angefertigte Pendelleuchtenfamilie, die aus drei Elementen mit einer hohen Individualität besteht.

Ironisch, Erinnerungen wachrufend, verspielt...Trottola bringt uns in die eigene Kindheit zurück. Sie ist in verschiedenen Ausführungen erhältlich, für das Haus wie für Objekte geeignet. Der modulare Bestandteil ermöglicht zahlreiche Kombinationen, um jeder Anforderung des Kunden gerecht zu werden. Die ganze Kollektion nutzt dimmbare Led-Lichtquellen.

Образ светильника и его название (Trottola - волчок, в переводе с итальянского), навеян старой детской игрушкой. Trottola - коллекция из трех подвесных светильников разных форм, выполненных из выдувного стекла. Ироничный, игривый, навивающий воспоминания, Trottola возвращает нас в детство. Доступный в разных решениях, светильник подойдет как для частного интерьера, так и для общественного. Модульность системы позволяет создавать бесчисленное количество комбинаций и кастомизаций, чтобы удовлетворить все потребности клиента. Вся коллекция оснащена диммируемыми светодиодами.

Struttura: rosone bianco - altre parti in metallo nelle colorazioni: nero opaco, oro opaco.

Frame: white canopy - other metal parts in the colors: matt black, matt gold.

Struktur: Baldachin Weiß - die anderen Teile aus Metall in den Farben: Mattschwarz, Mattgold.

Structure: rosette blanche - autres parties en métal dans es teintes : noir mat, or mat.

Estructura: rosetón blanco; otras partes de metal en los siguientes colores: negro mate, oro mate.

Структура: белый розон, остальные металлические части - матовый чёрный либо матовое золото.

Diffusore: vetro soffiato nelle colorazioni: trasparente, bianco seta, ambra metallizzato, fumè metallizzato.

Diffuser: blown glass in the following colors: transparent, white silk, metalized amber, metalized smoke-grey.

Diffusor: geblasenes Glas in den Farben: Transparent, Seidenweiß, Metallic-bernstein, Metallic-fumè.

Diffuseur: verre soufflé dans les teintes : transparent, blanc soie, ambre métallisé, fumè métallisé.

Difusor: vidrio soplado en los colores: transparente, blanco seda, ámbar metalizado, gris ahumado metalizado.

Рассеиватель: Выдувное стекло в цветах: прозрачный, белый шёлк, металлизированный янтарь, металлизированный дымчатый.



CT: Trasparente/Transparent



SE: Bianco seta/White silk



AM: Ambra Metallizzato/Metalized Amber



FU: Fumè metallizzato/Metalized smoke-grey

SOSPENSIONI (CAVO STANDARD CM 250)/PENDANT LAMPS (STANDARD CABLE CM 250)

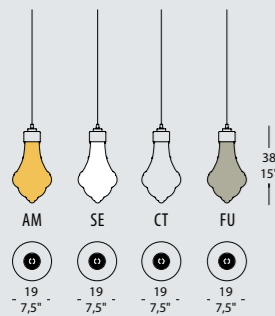

TROTTOLA SO SMALL

10W 1.400 Lm 2700K Cri>80 300 mA LED

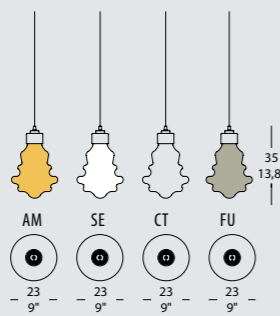
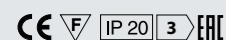

TROTTOLA SO MEDIUM

10W 1.400 Lm 2700K Cri>80 300 mA LED

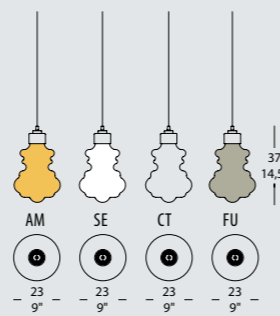
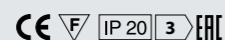

TROTTOLA SO BIG

10W 1.400 Lm 2700K Cri>80 300 mA LED

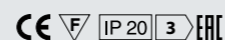

ROSONI/CANOPIES

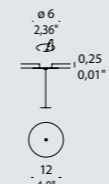

TROTTOLA IN-1

ROSONE A INCASSO A 1 LUCE CON DRIVER 220/240Vac 50-60 Hz
1-LIGHT RECESSED CANOPY WITH DRIVER 220/240Vac 50-60 Hz

TROTTOLA IN-1 DIM PD

ROSONE A INCASSO A 1 LUCE CON DRIVER DIMMERABILE PUSH 220/240Vac 50-60 HZ
1-LIGHT RECESSED CANOPY WITH PUSH DIMMABLE DRIVER 220/240Vac 50-60 HZ

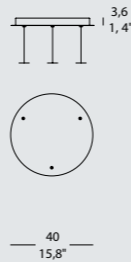

TROTTOLA R03

ROSONE A 3 LUCI CON DRIVER 220/240Vac 50-60 Hz
3-LIGHT CANOPY WITH DRIVER 220/240Vac 50-60 Hz

TROTTOLA R03 DIM PD

ROSONE A 3 LUCI CON DRIVER DIMMERABILE PUSH 220/240Vac 50-60 HZ
3-LIGHT CANOPY WITH PUSH DIMMABLE DRIVER 220/240Vac 50-60 HZ

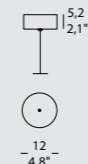

TROTTOLA R01

ROSONE A 1 LUCE CON DRIVER 220/240Vac 50-60 Hz
1-LIGHT CANOPY WITH DRIVER 220/240Vac 50-60 Hz

TROTTOLA R01 DIM PD

ROSONE A 1 LUCE CON DRIVER DIMMERABILE PUSH 220/240Vac 50-60 HZ
1-LIGHT CANOPY WITH PUSH DIMMABLE DRIVER 220/240Vac 50-60 HZ

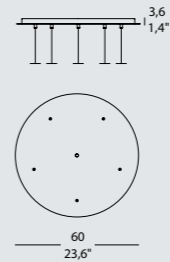

TROTTOLA R05

ROSONE A 5 LUCI CON DRIVER 220/240Vac 50-60 Hz
5-LIGHT CANOPY WITH DRIVER 220/240Vac 50-60 Hz

TROTTOLA R05 DIM PD

ROSONE A 5 LUCI CON DRIVER DIMMERABILE PUSH 220/240Vac 50-60 HZ
5-LIGHT CANOPY WITH PUSH DIMMABLE DRIVER 220/240Vac 50-60 HZ

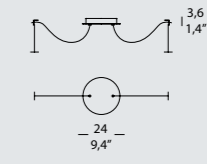

TROTTOLA R02

ROSONE A 2 LUCI CON DRIVER 220/240Vac 50-60 Hz
2-LIGHT CANOPY WITH DRIVER 220/240Vac 50-60 Hz

TROTTOLA R02 DIM PD

ROSONE A 2 LUCI CON DRIVER DIMMERABILE PUSH 220/240VAC 50-60 HZ
2-LIGHT CANOPY WITH PUSH DIMMABLE DRIVER 220/240Vac 50-60 HZ

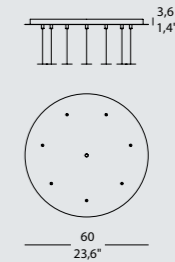

TROTTOLA R07

ROSONE A 7 LUCI CON DRIVER 220/240Vac 50-60 Hz
7-LIGHT CANOPY WITH DRIVER 220/240Vac 50-60 Hz

TROTTOLA R07 DIM PD

ROSONE A 7 LUCI CON DRIVER DIMMERABILE PUSH 220/240Vac 50-60 HZ
7-LIGHT CANOPY WITH PUSH DIMMABLE DRIVER 220/240Vac 50-60 HZ



SU RICHIESTA È POSSIBILE AVERE ANCHE DRIVER DIMMERABILE 1/10V
1/10V DIMMABLE DRIVER CAN BE SUPPLIED BY REQUEST

ESEMPI DI COMPOSIZIONE/EXAMPLES OF COMPOSITION

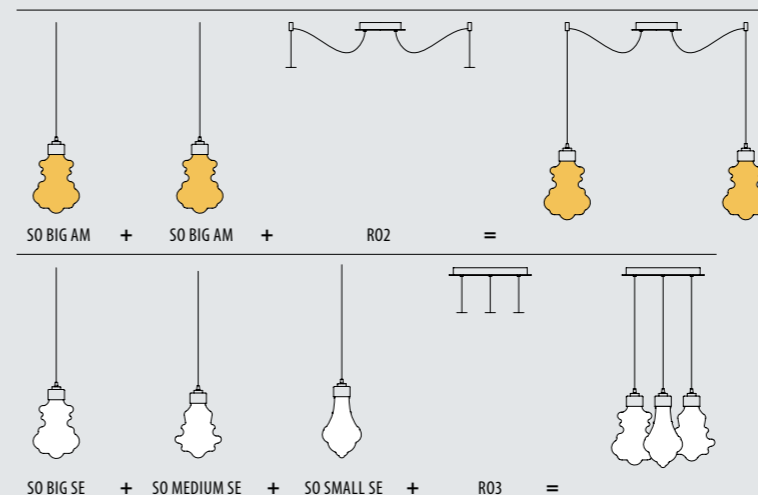



bia

•
Borri Manuel
Diagora Design

La riscoperta del
passato che illumina
il presente.

The rediscovery of
the past that enlightens
the present.



Bia_CORINTO SMALL, ATENE SMALL, ARGO SMALL + RO1



Bia_ATENE BIG + RO2



Bia_CORINTO SMALL + RO6



Bia_CORINTO SMALL, ATENE SMALL, ARGO SMALL + IN1



Bia ESEMPIO DI COMPOSIZIONE CON RO12 / EXAMPLE OF COMPOSITION WITH RO12

bia

technical data

Bia conduce ai giorni nostri i fasti dell'immortale cultura ellenica. Concepito come elemento di illuminazione decorativa contemporanea, affonda le sue radici nelle sinuose forme degli antichi vasi greci, icone di una civiltà che dal passato sino ad oggi ha rappresentato un faro per l'umanità. Bia viene realizzata in due misure, tre disegni e quattro differenti finiture. In ogni sua declinazione rispetta le parti che componevano i vasi ellenici, dall'orlo al piede, per offrire un'esperienza sensoriale caratterizzata da un gusto e una raffinatezza senza tempo.

Bia leads the glories of the immortal Hellenic culture to the present day. Conceived as an element of contemporary decorative lighting, it traces its roots back to the sinuous shapes of the ancient Greek vases, symbols of a civilization that has been a lighthouse for humanity from the past to this day. Bia is available in two sizes, three styles and four different finishes. In all versions it complies with the parts from which the Greek vases were made. From the lip to the foot, it offers a sensory experience characterised by timeless taste and refinement.

Bia führt den Ruhm der unsterblichen griechischen Kultur in die heutige Zeit. Als ein Element der zeitgenössischen dekorativen Beleuchtung konzipiert, hat Bia seine Wurzeln in den gewundenen Formen der antiken griechischen Vasen, Symbolen einer Zivilisation, die ein Leuchtturm für die Menschheit von der Vergangenheit bis zur Gegenwart ist. Bia ist in zwei Größen, drei Formen und vier verschiedenen Oberflächen erhältlich. In allen Versionen folgt Bia genau allen Teilen der griechischen Vasen, von dem Rand bis zum Fuß, um ein sinnliches Erlebnis zu bieten, das durch zeitlosen Geschmack und Raffinesse gekennzeichnet ist.

Bia mène à nos jours les fastes de l'immortelle culture hellénique. Conçue comme élément d'éclairage décoratif contemporain, elle plonge ses racines dans les formes sinueuses des anciens vases grecs, icônes d'une civilisation qui a été un phare pour l'humanité du passé à nos jours. Bia se réalise en deux mesures, trois dessins et quatre finitions différentes. Dans chacune des déclinaisons, elle respecte les parties qui composent les vases helléniques, de la lèvre au fond, pour offrir une expérience sensorielle qui est caractérisée par un goût et un raffinement intemporel.

Bia trae a nuestros días los fastos de la inmortal cultura helénica. Concebida como elemento de iluminación decorativa contemporáneo, hunde sus raíces en las formas sinuosas de las antiguas vasijas griegas, iconos de una civilización que ha representado un faro para la humanidad, del pasado hasta hoy. Bia se realiza en dos medidas, tres diseños y cuatro acabados diferentes. En cada su declinación respeta las partes que formaban las vasijas helénicas, del borde a la basa, para ofrecer una experiencia sensorial caracterizada por un gusto y una exquisitez sin tiempo.

Виа относит нас к бессмертной греческой культуре. Задуманный как элемент современного декоративного освещения, он берёт своё начало от форм древнегреческих ваз, символов цивилизации, которая и по сей день остаётся маяком для человечества. Виа выпускается в двух размерах, трёх стилях и четырёх различных отделках. Во всех версиях он соответствует элементам, из которых изготовлены греческие вазы.

Struttura: rosone bianco – altre parti in metallo nelle colorazioni: bianco opaco, nero opaco, oro opaco, rame opaco.

Frame: white canopy – other metal parts in the colors: matt white, matt black, matt gold, matt copper.

Struktur: Baldachin: weiß – die anderen Metallteile in den Farben: Mattweiß, Mattschwarz, Mattgold, Mattkupfer.

Structure: rosette blanche – autres parties métalliques dans les couleurs: blanc mat, noir mat, or mat, cuivre mat.

Estructura: florón blanco – otras partes de metal en los colores: blanco mate, negro mate, oro mate, cobre mate.

Структура: белый розон, остальные металлические части – матовый чёрный либо матовое золото.

Diffusore: Policarbonato satinato

Diffuser: Polycarbonate satin finish.

Diffusor: Satin Polycarbonat

Diffusor: Polycarbonate satiné.

Difusor: Policarbonato satinado.

Рассеиватель: Матовый поликарбонат

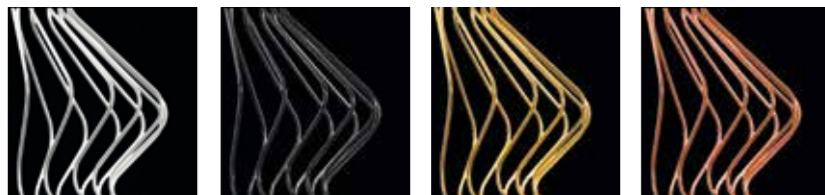

06: Bianco / White 07: Nero / Black 22: Oro / Gold 29: Rame / Copper

SOSPENSIONI (CAVO STANDARD CM 350 + DECENTRAMENTO)/PENDANT LAMPS (STANDARD CABLE CM 350 + OF CENTRE POSITION)

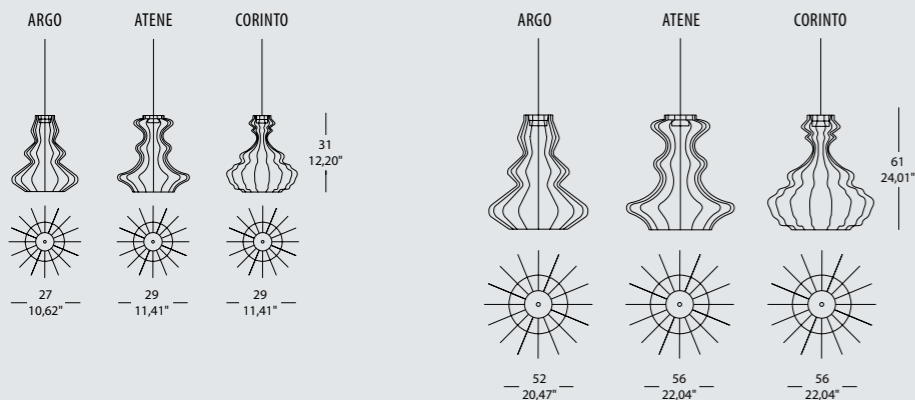

ROSONI/CANOPIES

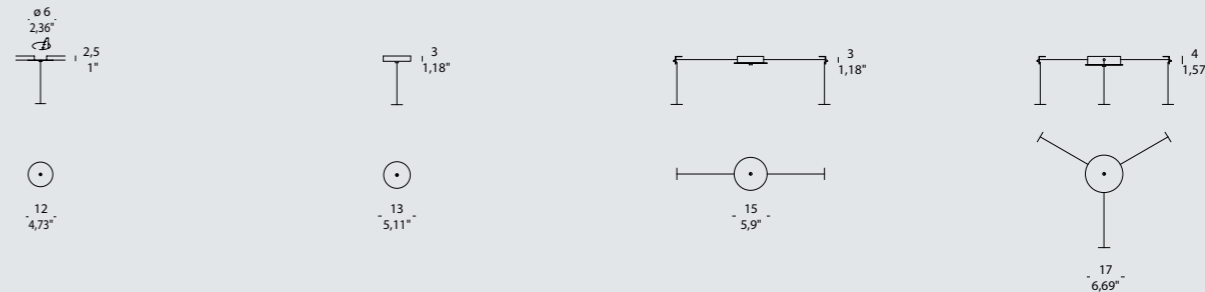

BIA IN-1
ROSONE A INCASSO A 1 LUCE
1-LIGHT RECESSED CANOPY

CE F IP 20 ENE

BIA RO-1
ROSONE A 1 LUCE
1-LIGHT CANOPY

CE F IP 20 ENE

BIA RO-2
ROSONE A 2 LUCI
2-LIGHT CANOPY

CE F IP 20 ENE

RAMETTO RO-3
ROSONE A 3 LUCI
3-LIGHT CANOPY

CE F IP 20 ENE

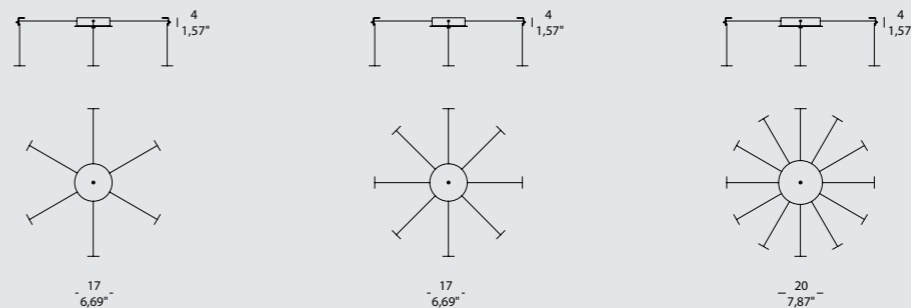

BIA RO-6
ROSONE A 6 LUCI
6-LIGHT CANOPY

CE F IP 20 ENE

BIA RO-8
ROSONE A 8 LUCI
8-LIGHT CANOPY

CE F IP 20 ENE

BIA RO-12
ROSONE A 12 LUCI
12-LIGHT CANOPY

CE F IP 20 ENE

ESEMPI DI COMPOSIZIONE/EXAMPLES OF COMPOSITION

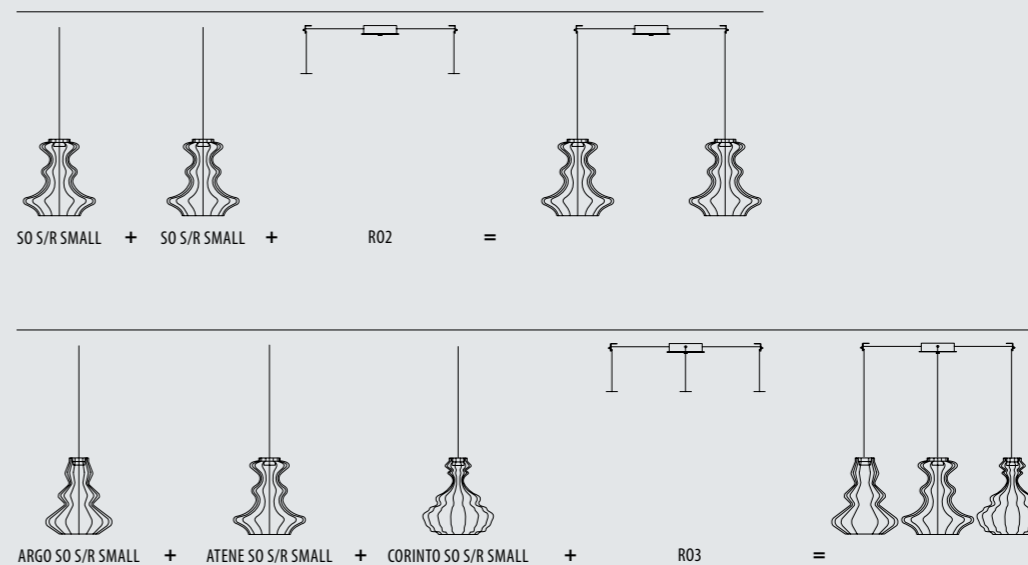



minerva

·
Chiamonte Marin

Accendi il mio fuoco.
Light my fire.



Minerva SS + RO2



Minerva SS + RO3



Minerva SF + IN1

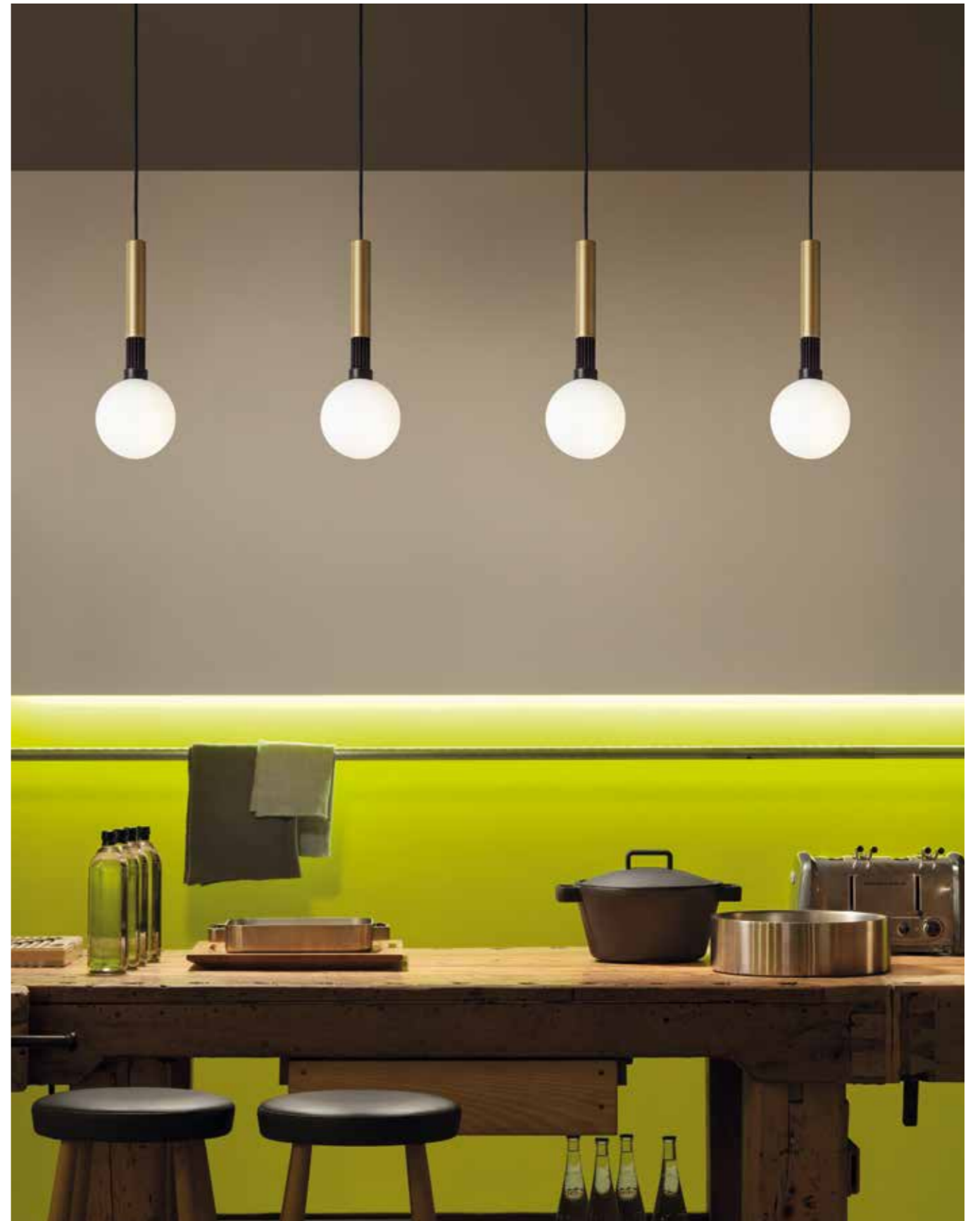

MINERVA SF + IN1





Minerva SC + RO5

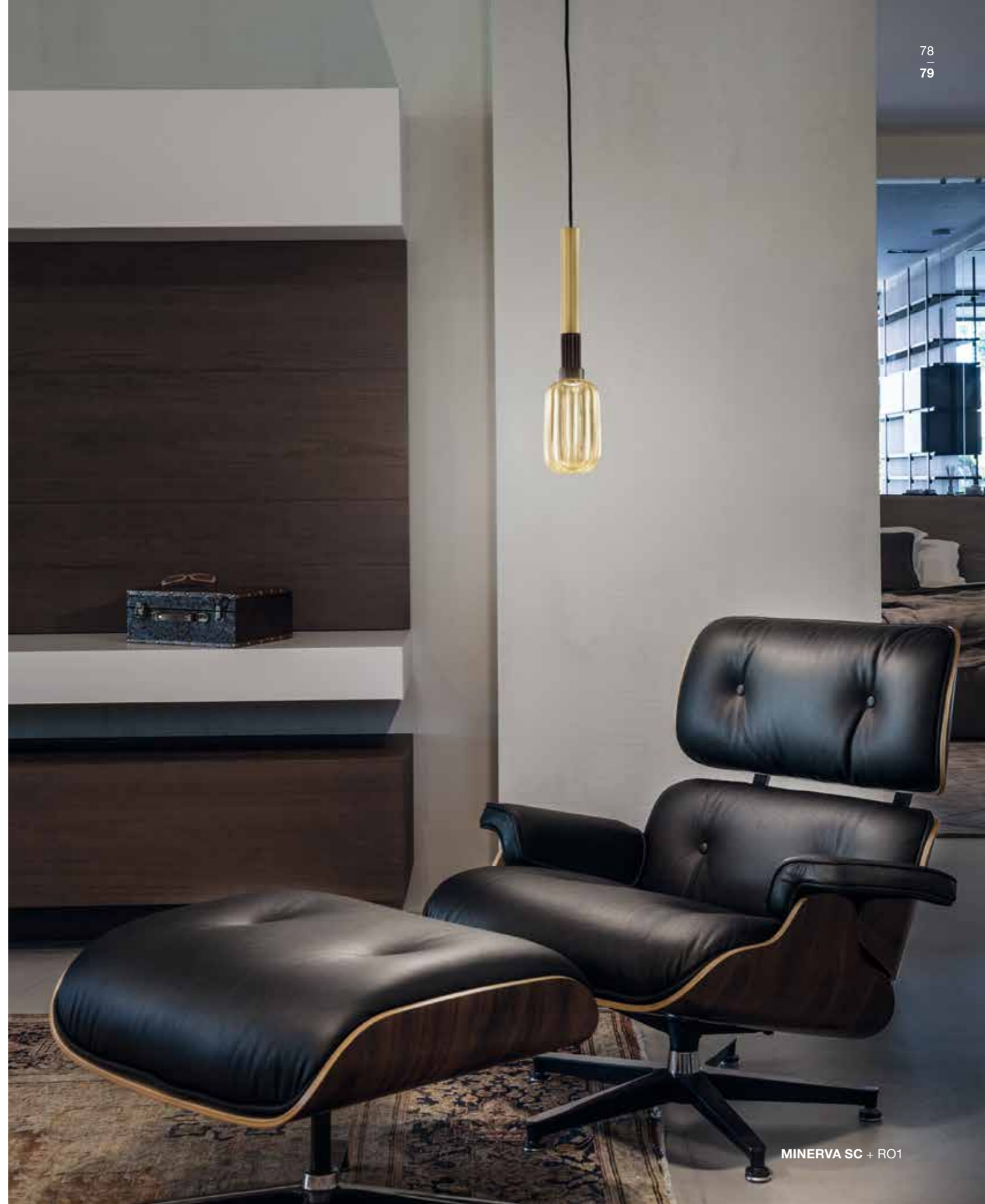

MINERVA SC + RO1

minerva

technical data

Un nome che riporta al passato, agli indimenticabili fiammiferi Minerva, prodotti che per decenni hanno caratterizzato la quotidianità di milioni di Italiani. Proprio da questa semplice fonte di fuoco e luce prende vita una sospensione che si caratterizza per il posizionamento del dissipatore di calore, pensato per rappresentare il punto focale dell'intera struttura. I diffusori sono in vetro soffiato, dai colori molto tenui e tramati con lavorazioni tipiche del vetro di Murano.

A name that brings back the past, to the unforgettable Italian Minerva matches, products that have characterized the daily life of millions of Italians for decades. This suspension comes to life taking inspiration from this simple source of fire. It is characterised by the position of the heat sink, designed to represent the key point of the entire item. The diffusers are in blown glass, in very soft colors, created with the typical Murano glass processing techniques.

Ein Name, der Erinnerungen weckt. Die unvergesslichen italienischen Minerva Wachsstreichhölzer. Produkte, die seit Jahrzehnten das tägliche Leben von Millionen Italienern geprägt haben. Diese Pendelleuchte wird zum Leben erweckt und inspiriert von dieser einfachen Feuerquelle. Sie ist charakterisiert durch die Position des Kühlkörpers, um den Schlüsselpunkt des gesamten Gegenstandes darzustellen. Der Diffusor ist aus geblasenem Glas, in samtweichen Farben, mit den typischen Verarbeitungstechniken muranesischer Glasbläserkunst hergestellt.

C'est un nombre qui rappelle le passé, les allumettes italiennes Minerva. Produits qui ont caractérisés la vie quotidienne des milliers d'Italiens pendant des décennies. La suspension prend vie de cette simple source de feu et de lumière ; elle se caractérise par l'emplacement du diffuseur de chaleur, pensé pour représenter le point focal de l'entière structure. Les diffuseurs sont en verre soufflé, couleurs intensément douces et modelés avec le façonnage typique du verre de Murano.

Es un nombre que lleva al pasado, a las cerillas italianas Minerva, que se produjeron durante décadas y que caracterizaron la cotidianidad de millones de italianos. Precisamente de esta simple fuente de fuego y luz, cobra vida una suspensión que se caracteriza por la colocación del disipador de calor, pensado para representar el punto focal de toda la estructura. Los difusores son de vidrio soplado, de colores suaves y con tramas, que llevan las elaboraciones típicas del vidrio de Murano.

Имя, которое относит нас в прошлое, к незабываемым итальянским спичкам Minerva, продукту характеризовавшему жизнь миллионов итальянцев, на протяжении десятилетий. Вдохновение на создание данного светильника, пришло от кого простого источника огня. Диффузоры из выдувного стекла в очень мягких цветах, выполнены с применением традиционных техник производства муранского стекла.

Struttura: rosone bianco, altre parti in metallo nelle colorazioni: nero opaco, oro opaco.

Diffusore: vetro soffiato SC e SS nelle colorazioni: bianco latte lucido, giallo topazio, fumè, cristallo e oro 24 Kt. Vetro soffiato SF: bianco latte satinato.

Frame: white canopy - other metal parts in the colors: matt black, matt gold.

Diffuser: blown glass SC and SS in the following colours: Glossy milk white, topaz yellow, smoke grey, crystal and gold 24 Kt. Blown glass SF: milk white satin finish.

Struktur: Baldachin: Weiß – Die anderen Metallteile in den Farben: Mattschwarz, Mattgold.

Diffusor: SC und SS geblasenes Glas in den Farben: glänzend Milchweiß, Gelbtapas, Fumè, Kristallglas und Gold 24 Kt - SF geblasenes Glas: Milchweiß satiniert.

Structure: rosette blanche – autres parties métalliques dans les couleurs: noir mat, or mat.

Diffuseur: verre soufflé SC et SS dans les couleurs: blanc lait brillant, jaune topaze, fumè, cristal et or 24 Kt. Verre soufflé SF: blanc lait satiné.

Estructura: florón blanco – otras partes de metal en los colores: negro mate, oro mate.

Difusor: vidrio soplado SC e SS en los colores: blanco leche brillante, amarillo topacio, gris ahumado, cristal y oro 24 Kt. Vidrio soplado SF: blanco leche satinado.

Структура: белый розон, остальные металлические части - матовый чёрный лилово-золотое.

Рассеиватель: Выдувное стекло SC и SS в следующих цветах: желтый топаз, дымчатый, хрусталь и Золото 24 карата. Выдувное стекло SF: Молочно-белое сатирированное стекло.



BI: Bianco latte lucido/
Glossy milk white



CO: Cristallo e oro 24 Kt/
Crystal and gold 24 Kt



FE: Fumè/
Smoke grey



TP: Giallo topazio/
Topaz yellow



07: Nero opaco/
Matt black



22: Oro opaco/
Matt gold



BI: Bianco latte lucido/
Glossy milk white



CO: Cristallo e oro 24 Kt/
Crystal and gold 24 Kt



FE: Fumè/
Smoke grey



TP: Giallo topazio/
Topaz yellow



BS: bianco latte satinato/
Milk white satin finish

SOSPENSIONI (CAVO STANDARD CM 250)/PENDANT LAMPS (STANDARD CABLE CM 250)

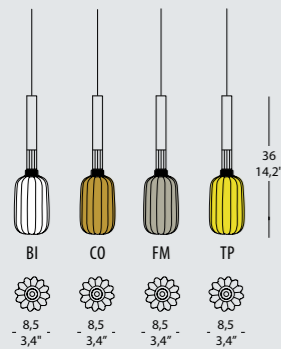

MINERVA SC

6,2W 666 Lm 2700K Cri>80 24Vdc LED

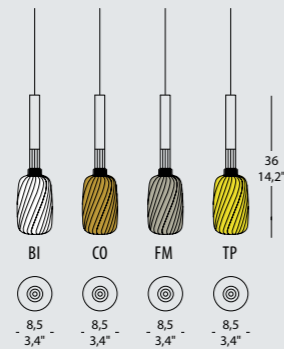

MINERVA SS

6,2W 666 Lm 2700K Cri>80 24Vdc LED

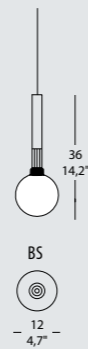

MINERVA SF

6,2W 666 Lm 2700K Cri>80 24Vdc LED



ESEMPI DI COMPOSIZIONE/ EXAMPLES OF COMPOSITION

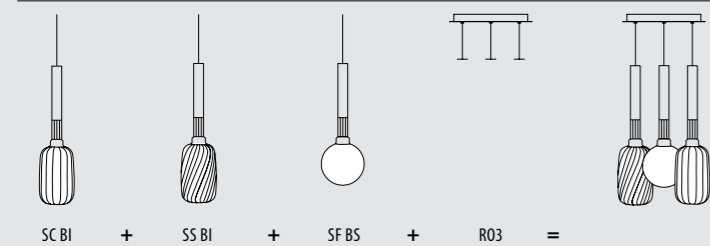
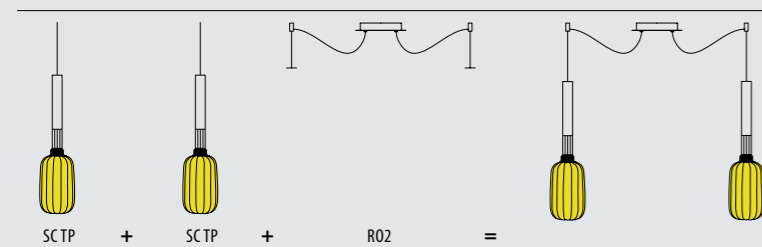

ROSONI/CANOPIES

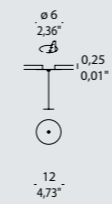

MINERVA IN-1

ROSONE A INCASSO A 1 LUCE CON DRIVER 220/240Vac 50-60 Hz
1-LIGHT RECESSED CANOPY WITH DRIVER 220/240Vac 50-60 Hz

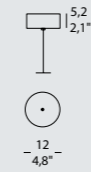

MINERVA R01

ROSONE A 1 LUCE CON DRIVER 220/240Vac 50-60 Hz
1-LIGHT CANOPY WITH DRIVER 220/240Vac 50-60 Hz

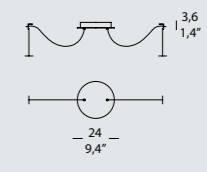

MINERVA R02

ROSONE A 2 LUCI CON DRIVER 220/240Vac 50-60 Hz
2-LIGHT CANOPY WITH DRIVER 220/240Vac 50-60 Hz

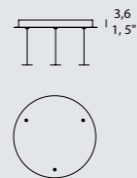

MINERVA R03

ROSONE A 3 LUCI CON DRIVER 220/240Vac 50-60 Hz
3-LIGHT CANOPY WITH DRIVER 220/240Vac 50-60 Hz

MINERVA R03 DIM PD

ROSONE A 3 LUCI CON DRIVER DIMMERABILE PUSH
220/240Vac 50-60 HZ
3-LIGHT CANOPY WITH PUSH DIMMABLE DRIVER
220/240Vac 50-60 HZ

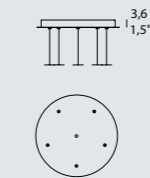

MINERVA R05

ROSONE A 5 LUCI CON DRIVER 220/240Vac 50-60 Hz
5-LIGHT CANOPY WITH DRIVER 220/240Vac 50-60 Hz

MINERVA R05 DIM PD

ROSONE A 5 LUCI CON DRIVER DIMMERABILE PUSH
220/240Vac 50-60 HZ
5-LIGHT CANOPY WITH PUSH DIMMABLE DRIVER
220/240Vac 50-60 HZ

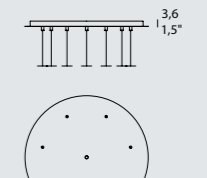

MINERVA R07

ROSONE A 7 LUCI CON DRIVER 220/240Vac 50-60 Hz
7-LIGHT CANOPY WITH DRIVER 220/240Vac 50-60 Hz

MINERVA R07 DIM PD

ROSONE A 7 LUCI CON DRIVER DIMMERABILE PUSH
220/240Vac 50-60 HZ
7-LIGHT CANOPY WITH PUSH DIMMABLE DRIVER
220/240Vac 50-60 HZ





memoria



Dima Loginoff

Art Deco in chiave
moderna e chic.

Art Deco on a modern
and chic take.



Memoria C1 A5 / S2 A5 + IN1



Memoria_ESEMPIO DI COMPOSIZIONE CON R07 / EXAMPLE OF COMPOSITION WITH R07



S1-A0 S1-A1 S1-A2 S1-A3 S1-A4 S1-A5 S1-A6



S2-A0 S2-A1 S2-A2 S2-A3 S2-A4 S2-A5 S2-A6



C1-A0 C1-A1 C1-A2 C1-A3 C1-A4 C1-A5 C1-A6



C2-A0 C2-A1 C2-A2 C2-A3 C2-A4 C2-A5 C2-A6

Dettagli/Details

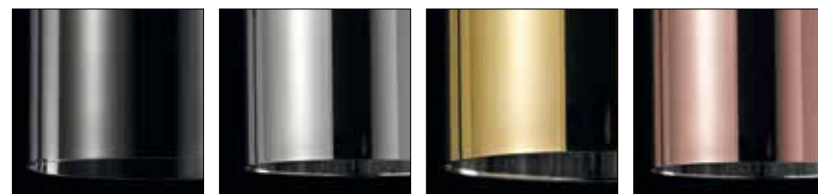

Trasparente/
Transparent Cromo/
Chrome Oro/
Gold Rame/
Copper

memoria

technical data

Stile internazionale e ricercatezza italiana, per una collezione di lampade a sospensione che rimanda all'estetica dell'Art Déco, rivisitata in chiave più moderna e chic. Disponibile in versione singola o multipla, sia circolare che lineare, Memoria può acquisire ulteriore esclusività giocando con i volumi dei suoi elementi e le diverse tonalità dei diffusori in vetro: trasparenti o metallizzati in oro, cromo e rame, abbinati a cavi rivestiti in calza metallica dello stesso colore. L'effetto ottenuto con i diffusori metallizzati, definito "trans-mirror", esalta il fascino della lampada generando a luce accesa sofisticate trasparenze. La versione con diffusore trasparente invece, racchiude al suo interno una luminosa sfera in vetro soffiato, testimone della cura del dettaglio tipica del brand. Tutta la collezione utilizza sorgenti a LED.

With a reference to Art Decò, revisited in a more modern and chic key, this collection of pendant lamps is the representation of International style and Italian preciousness. Available in single and multiple, as well as in circular and linear versions, Memoria can gain additional exclusivity playing with the volumes of its elements and the different shades of glass diffusers: transparent or metalized in gold, chrome and copper, combined with cables of the same color, coated with metal braid. The "trans-mirror" effect, obtained with the metalized diffusers, enhances the charm of the lamp creating sophisticated transparencies when the light is on. The version with the transparent diffuser, instead, contains within it a bright ball in blown glass, a witness of the attention to detail, that is a typical element of the brand. The entire collection uses LED sources.

Internationaler Stil und italienische Raffinesse für eine Lampenkollektion mit Abhängung, die sich an die Ästhetik des Art Deco in moderner und eleganter Form anlehnt. Sie ist erhältlich in einfacher oder mehrfacher Version, sowohl kreisförmig als auch linear. Memoria gewinnt zusätzliche Exklusivität durch das Spiel mit dem Volumen seiner Elemente und den unterschiedlichen Tonalitäten (transparent oder metallisiert in Gold, verchromt und Kupfer) der Glas-Lampenschirme im Einklang mit den umkleideten Kabeln in der gleichen Farbe. Der sogenannte "Spiegel-Effekt" der durch die metallisierten Diffusoren erzielt wird, erhöht den Charme der Lampe die bei eingeschaltetem Licht anspruchsvolle Transparenz erzeugt. Die Ausführung mit transparentem Diffusor hingegen, umschließt im Inneren eine helle Kugel in geblasenem Glas. Der Beweis für die Liebe zum Detail, typisch für unsere Marke. Die ganze Kollektion ist exklusiv mit LED-Lichtquellen ausgestattet.

Style international et raffinement italien, pour une collection de lampes à suspension qui renvoie à l'esthétique de l'Art Déco, revue sous un jour plus moderne et chic. Fournie dans la version simple ou multiple, circulaire et linéaire, Memoria peut devenir plus exclusive en jouant avec les volumes de ces éléments et les différentes tonalités des diffuseurs en verre: transparents ou métallisés en or, chrome et cuivre, associés à des câbles revêtus d'une gaine métallique de la même couleur. L'effet obtenu avec les diffuseurs métallisés, défini "trans-mirror", exalte le charme de la lampe en générant des transparences sophistiquées lorsqu'elle est allumée. En revanche, la version avec un diffuseur transparent, contient une sphère lumineuse en verre soufflé, témoignant du soin du détail typique de la marque. Toute la collection utilise des sources à LED.

Estilo internacional y elegancia italiana para una colección de lámparas de suspensión que recuerda la estética del Art Déco revisitada en clave más moderna y chic. Disponible en versión única o múltiple, tanto circular como lineal, Memoria puede adquirir más exclusividad jugando con los volúmenes de sus elementos y los varios tonos de los difusores en vidrio: transparentes o metalizados en oro, cromo y cobre, combinados con cables forrados en trenza metálica del mismo color. El efecto obtenido con los difusores metalizados, definido "trans-mirror", exalta el encanto de la lámpara generando sofisticadas transparencias con la luz encendida. La versión con difusor transparente en cambio, encierra en su interior una luminosa esfera de vidrio soplado, testigo del cuidadoso detalle, típico de la marca. Toda la colección utiliza fuentes de LED.

Интернациональный стиль и итальянская изысканность, для роскошной коллекции подвесных светильников, которая возвращает к эстетике стиля ар-деко, переосмысленной в современном ключе. Предоставлена в виде одиночного светильника или группы светильников, как с линейным, так и с круговым расположением, Memoria может приобрести дополнительную исключительность, играя с объемами своих элементов и разными оттенками своих рассеивателей из стекла: прозрачных или металлизированных, доступных в следующих цветах: золото, хром и медь; с проводами, в металлической оплетке такого же цвета. Эффект, полученный с применением металлизированных рассеивателей, названный "trans-mirror", подчеркивает обаяние светильника, создавая во включенном состоянии изысканную прозрачность. Версия с прозрачным рассеивателем, напротив, заключает внутри себя светящуюся сферу из дутого стекла - свидетеля заботы о деталях, типичной для бренда. Во всей коллекции в качестве источника света используется LED.

Struttura: metallo bianco opaco, con particolari in cromo, oro e rame. **Diffusore:** vetro trasparente, cromo, oro e rame, in diverse combinazioni.

Struktur: metall mattweiß, Details in Chrom, Gold und Kupfer. **Diffusor:** Glas transparent, Chrom, Gold und Kupfer, verschiedene Kombinationen möglich.

Estructura: metal blanco opaco, con detalles de cromo, oro y cobre. **Difusor:** vidrio transparente, cromo oro y cobre, en varias combinaciones.

Frame: matt white metal, with details in chrome, gold and copper. **Diffuser:** glass in transparent, chrome, gold and copper, in various combinations.

Structure: métal blanc opaque, avec des détails en chrome, or et cuivre. **Diffuseur:** verre transparent, chrome, or et cuivre, dans différentes combinaisons.

Структура: белый матовый металл с деталями, выполненными в следующих расцветках: хром, золото и медь. **Рассеиватель:** возможные расцветки: прозрачный, хром, золото и медь, в различных сочетаниях.

SOSPENSIONI (CAVO STANDARD CM 200)/PENDANT LAMPS (STANDARD CABLE CM 200)

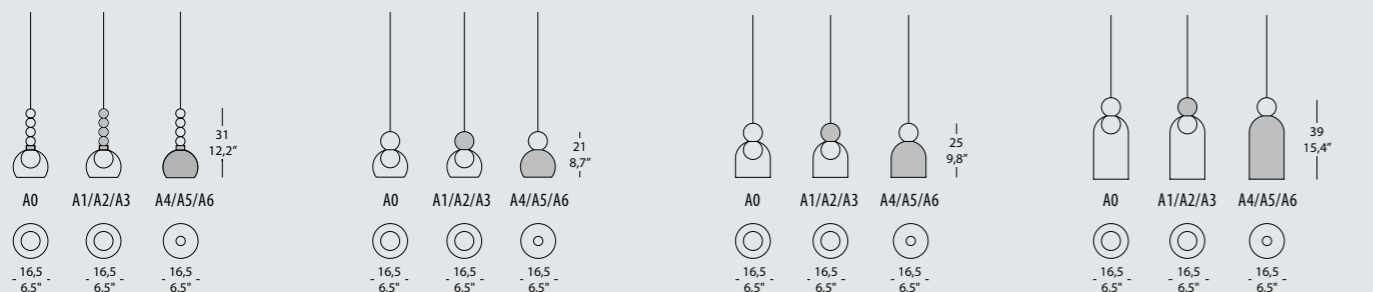

MEMORIA S1

4,7W 480 Lm 3000K Cri>80 500 mA LED

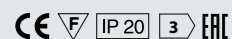

MEMORIA S2

4,7W 480 Lm 3000K Cri>80 500 mA LED

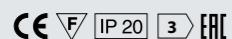

MEMORIA C1

4,7W 480 Lm 3000K Cri>80 500 mA LED

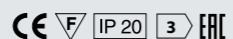

MEMORIA C2

4,7W 480 Lm 3000K Cri>80 500 mA LED

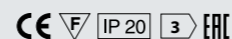

ESEMPI DI COMPOSIZIONE/EXAMPLES OF COMPOSITION

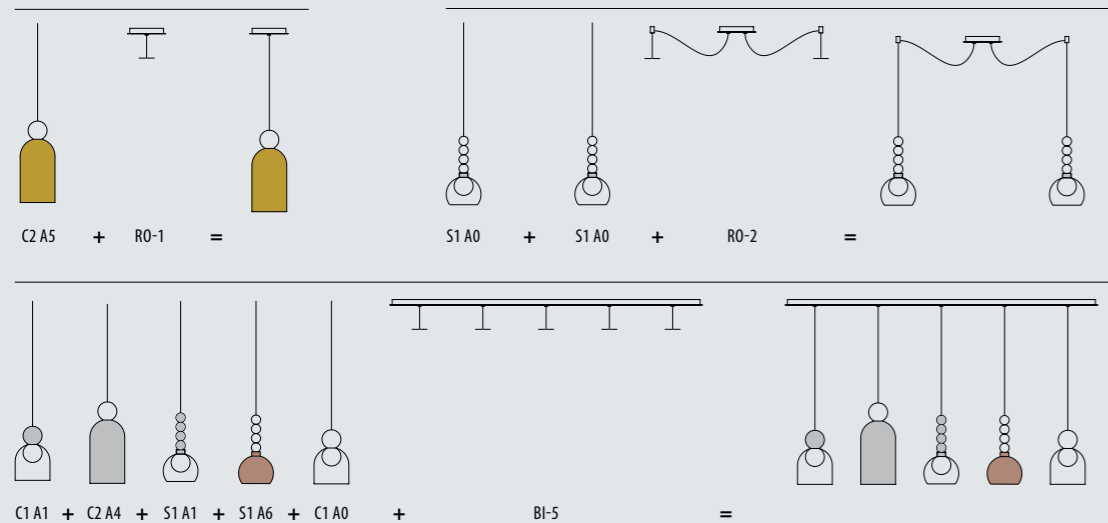

ROSONI/CANOPIES

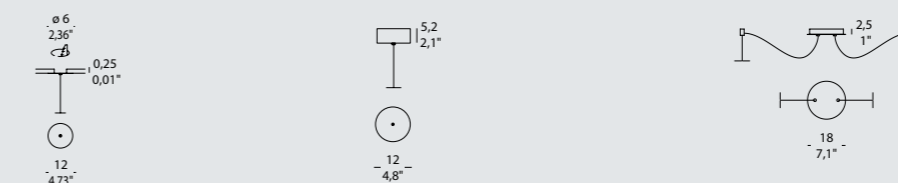

MEMORIA IN-1

ROSONE A INCASSO A 1 LUCE
CON DRIVER 220/240
1-LIGHT RECESSED CANOPY
WITH DRIVER 220/240



MEMORIA RO-1

ROSONE A 1 LUCE CON DRIVER 220/240V
1-LIGHT CANOPY WITH DRIVER 220/240V



MEMORIA RO-2

ROSONE A 2 LUCI CON DRIVER 220/240V
2-LIGHT CANOPY WITH DRIVER 220/240V

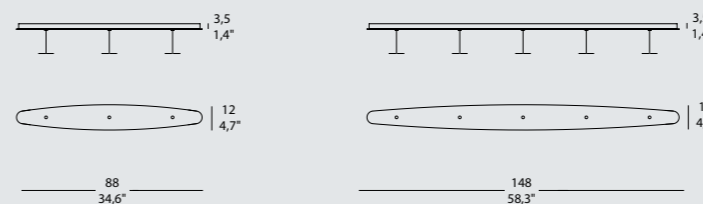

MEMORIA BI-3

BINARIO A 3 LUCI CON DRIVER 220/240V
3-LIGHT TRACK WITH DRIVER 220/240V



MEMORIA BI-5

BINARIO A 5 LUCI CON DRIVER 220/240V
5-LIGHT TRACK WITH DRIVER 220/240V

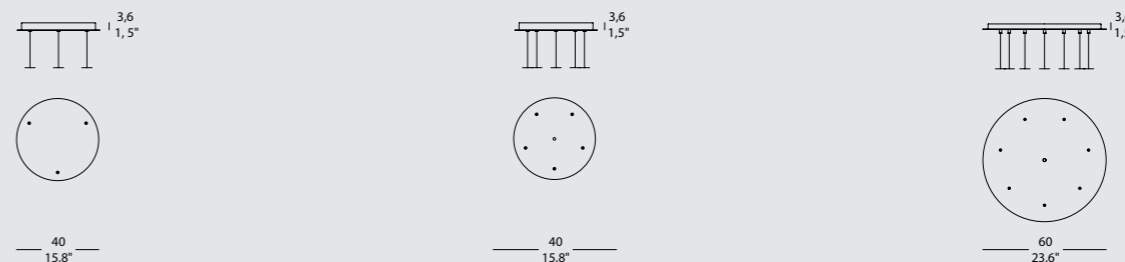

MEMORIA R03 C

ROSONE A 3 LUCI CON DRIVER 220/240Vac 50-60 Hz
3-LIGHT CANOPY WITH DRIVER 220/240Vac 50-60 Hz

MEMORIA R03 C DIM PD

ROSONE A 3 LUCI CON DRIVER DIMMERABILE PUSH
220/240Vac 50-60 HZ
3-LIGHT CANOPY WITH PUSH DIMMABLE DRIVER
220/240Vac 50-60 HZ



MEMORIA R05

ROSONE A 5 LUCI CON DRIVER 220/240Vac 50-60 Hz
5-LIGHT CANOPY WITH DRIVER 220/240Vac 50-60 Hz

MEMORIA R05 DIM PD

ROSONE A 5 LUCI CON DRIVER DIMMERABILE PUSH
220/240Vac 50-60 HZ
5-LIGHT CANOPY WITH PUSH DIMMABLE DRIVER
220/240Vac 50-60 HZ



MEMORIA R07

ROSONE A 7 LUCI CON DRIVER 220/240Vac 50-60 Hz
7-LIGHT CANOPY WITH DRIVER 220/240Vac 50-60 Hz

MEMORIA R07 DIM PD

ROSONE A 7 LUCI CON DRIVER DIMMERABILE PUSH
220/240Vac 50-60 HZ
7-LIGHT CANOPY WITH PUSH DIMMABLE DRIVER
220/240Vac 50-60 HZ



SU RICHIESTA È POSSIBILE AVERE ANCHE DRIVER DIMMERABILE 1/10V
1/10V DIMMABLE DRIVER CAN BE SUPPLIED BY REQUEST



vintage

•
Stefano Mandruzzato

Elegante, semplice, raffinata.
Elegant, simple, refined.



Una collezione di lampade di ispirazione d'antan dall'eleganza attuale e dall'essenza innovativa.

I paralumi, in tre forme dall'inconfondibile richiamo vintage, sono rivestiti con un esclusivo velluto stropicciato, che ne rinnova lo stile e arricchisce la lampada di un prezioso effetto cangiante, che li rende unici.

Disponibile in eleganti colorazioni e in diverse versioni a sospensione e da parete, Vintage si accosta in maniera raffinata all'arredamento classico, creando al contrario brillanti contrasti con l'arredo più moderno.

La variante a sospensione piccola viene impreziosita da un elemento in vetro soffiato con la tipica lavorazione Muranese del "rigadin".

Une collection de lampes d'antan d'une élégance actuelle et à l'essence innovante.

Les abat-jours, aux trois formes rappelant le vintage de façon remarquable, sont revêtus d'un velours froissé exclusif, qui en renouvelle le style et enrichit la lampe d'un effet chatoyant précieux qui en fait des objets uniques.

Fournie dans d'élégantes couleurs et dans différentes versions à suspension et murales, Vintage peut-être assortie avec raffinement à un ameublement classique, en créant des contrastes brillants avec la décoration plus moderne.

La variante à petite suspension est enrichie d'un élément en verre soufflé suivant la méthode de travail typique de Murano appelée le "rigadin".

Current elegance and innovative essence: a collection of lamps inspired by a d'antan style. The exclusive crumpled velvet, with which the three vintage lampshades are coated, renews the style and enriches the lamp of a precious iridescent effect, which makes the shade unique.

Available in stylish colors and in different pendant and wall versions, Vintage adapts elegantly to the classic furnishing, creating, on the contrary, brilliant contrasts with the more modern furniture.

The version with the small pendant lamp is enhanced by an element in blown glass created through the typical Murano processing technique "rigadin".

Una colección de lámparas de inspiración de antaño, de elegancia actual y de esencia innovadora.

Las pantallas en tres formas de inconfundible evocación de antaño están forradas con un terciopelo arrugado y exclusivo que renueva el estilo y enriquece la lámpara con un preciso efecto cambiante haciéndolas únicas.

Disponibile en elegantes colores y en varias versiones, de suspensión y de pared, Vintage se combina en modo refinado con la decoración clásica creando al contrario brillantes contrastes con el mobiliario más moderno.

La variante de suspensión pequeña es valorizada por un elemento de vidrio soplado con el típico trabajo de Murano del "rigadin".

Eine Lampenkollektion nach historischer Inspiration, mit aktueller Eleganz und innovativer Essenz.

Die Lampenschirme mit ihren 3 unverwechselbaren Vintage-Formen sind mit einem exklusiven und zerknitterten Samtstoff verkleidet. Dieser erneuert ihren Stil und bereichert die Lampe mit einem edlen und irisierenden Effekt. Das macht sie einzigartig. Sie ist erhältlich in eleganten Farben und diversen Versionen mit Abhängung und für die Wandapplikation. Vintage integriert sich in edler Art und Weise in die klassische Einrichtung und erzeugt im Gegensatz brillante Kontraste mit der modernen Einrichtung. Die Ausführung mit kleiner Abhängung wird durch ein Element in geblasenem "Rigadin"-Glas mit der typischen "Murano"-Verarbeitung aufgewertet.

Коллекция светильников, созданная под вдохновением прошлого, с актуальной элегантностью и инновационной сущностью.

Уникальный велюр с эффектом жатости, из которого выполнены три винтажных абажура, обновляет стиль и придает светильнику эффект «шанжан», делая его уникальными.

Коллекция предоставляется в элегантных расцветках и различных версиях: подвесной и настенной, Vintage приближается в утонченной манере к классической обстановке, создавая, наоборот, превосходный контраст с самой современной обстановкой.

Маленький подвесной светильник украшен элементом из типичного дутого муранского стекла "rigadin".

Struttura: metallo cromato.
Diffusore: paralume in velluto stropicciato nei colori: avorio, nero, rosso sultano, crema caffè, glicine, acquamarina e oro.

Frame: chromed metal.
Diffuser: shade in crumpled velvet in: ivory, black, sultan-red, coffee-cream, wisteria, aquamarine and gold.

Struktur: Metall verchromt.
Diffusor: Lampenschirm mit zerknittertem Samtstoff in den Farben: Elfenbein, Schwarz, Sultan Rot, Kaffeesahne, Glyzinie, Aquamarin und Gold.

Structure: métal chromé.
Diffuseur: abat-jour en velours froissé dans les teintes ivoire, noir, rouge sultan, crème café, glycine, aigue-marine et or.

Estructura: metal cromado.
Difusor: pantalla de terciopelo arrugado en los colores: marfil, negro, rojo sultán, crema de café, glicina, aguamarina y oro.

Структура: Хромированный металл.
Рассеиватель: Абажур из велюра с эффектом жатости предоставляется в следующих вариантах цвета: слоновая кость, черный, темно-красный, кремовый, глициниевый, цвет морской волны и золотой.

Campioni colore diffusore/Diffuser sample colors



AQ: Acquamare/
Aquamarine



GL: Glicine/Wisteria



AV: Avorio/Ivory



SR: Rosso sultano/
Sultan red

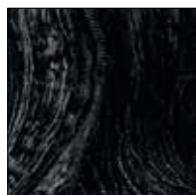

NE: Nero/Black



OR: Oro/Gold



CC: Crema caffè/
Coffee cream

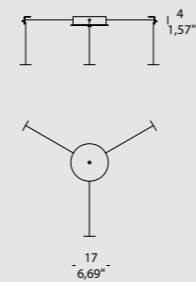

VINTAGE RO-3
ROSONE A 3 LUCI
3-LIGHT CANOPY

CE F IP 20 EAC

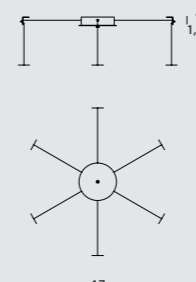

VINTAGE RO-6
ROSONE A 6 LUCI
6-LIGHT CANOPY

CE F IP 20 EAC

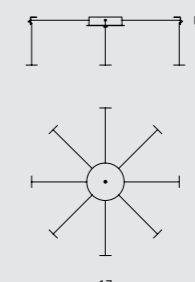

VINTAGE RO-8
ROSONE A 8 LUCI
8-LIGHT CANOPY

CE F IP 20 EAC

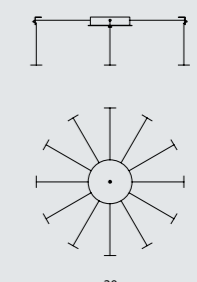

VINTAGE RO-12
ROSONE A 12 LUCI
12-LIGHT CANOPY

CE F IP 20 EAC

SOSPENSIONI (CAVO STANDARD CM 350 + DECENTRAMENTO)/PENDANT LAMPS (STANDARD CABLE CM 350 + DECENTRAMENTO)

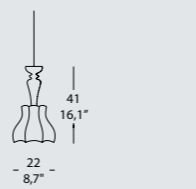

VINTAGE GLASS SO S/R PAGODA

1 x MAX 53W E27 alo. ENERGY SAVER
o/or
1 x MAX 8W E27 LED

CE F IP 20 1 EAC

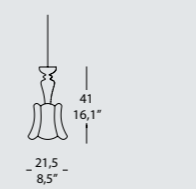

VINTAGE GLASS SO S/R BAROCCO

1 x MAX 53W E27 alo. ENERGY SAVER
o/or
1 x MAX 8W E27 LED

CE F IP 20 1 EAC

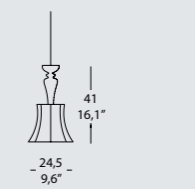

VINTAGE GLASS SO S/R CAMPANA

1 x MAX 53W E27 alo. ENERGY SAVER
o/or
1 x MAX 8W E27 LED

CE F IP 20 1 EAC

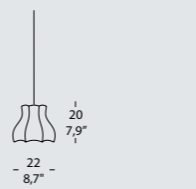

VINTAGE GLASS SO S/R PAGODA

1 x MAX 53W E27 alo. ENERGY SAVER
o/or
1 x MAX 8W E27 LED

CE F IP 20 1 EAC

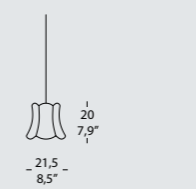

VINTAGE GLASS SO S/R BAROCCO

1 x MAX 53W E27 alo. ENERGY SAVER
o/or
1 x MAX 8W E27 LED

CE F IP 20 1 EAC

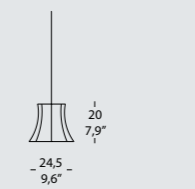

VINTAGE GLASS SO S/R CAMPANA

1 x MAX 53W E27 alo. ENERGY SAVER
o/or
1 x MAX 8W E27 LED

CE F IP 20 1 EAC

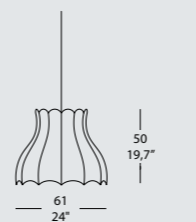

VINTAGE GLASS SO S/R PAGODA

1 x MAX 105W E27 alo. ENERGY SAVER
o/or
1 x MAX 21W E27 LED

CE F IP 20 1 EAC

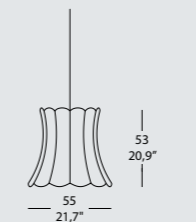

VINTAGE GLASS SO S/R BAROCCO

1 x MAX 105W E27 alo. ENERGY SAVER
o/or
1 x MAX 21W E27 LED

CE F IP 20 1 EAC

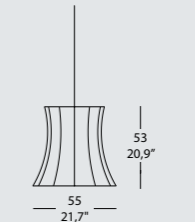

VINTAGE GLASS SO S/R CAMPANA

1 x MAX 105W E27 alo. ENERGY SAVER
o/or
1 x MAX 21W E27 LED

CE F IP 20 1 EAC

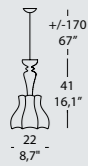

VINTAGE GLASS SO 1 PAGODA

1 x MAX 53W E27 alo. ENERGY SAVER
o/or
1 x MAX 8W E27 LED
CE F IP20 1 EAC

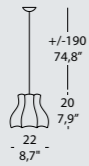

VINTAGE SO 1 PAGODA

1 x MAX 53W E27 alo. ENERGY SAVER
o/or
1 x MAX 8W E27 LED
CE F IP20 1 EAC

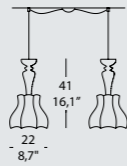

VINTAGE GLASS SO 2 PAGODA

2 x MAX 53W E27 alo. ENERGY SAVER
o/or
2 x MAX 8W E27 LED
CE F IP20 1 EAC

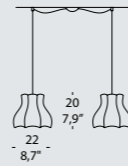

VINTAGE SO 2 PAGODA

2 x MAX 53W E27 alo. ENERGY SAVER
o/or
2 x MAX 8W E27 LED
CE F IP20 1 EAC

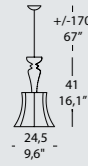

VINTAGE GLASS SO 1 CAMPANA

1 x MAX 53W E27 alo. ENERGY SAVER
o/or
1 x MAX 8W E27 LED
CE F IP20 1 EAC

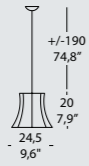

VINTAGE SO 1 CAMPANA

1 x MAX 53W E27 alo. ENERGY SAVER
o/or
1 x MAX 8W E27 LED
CE F IP20 1 EAC

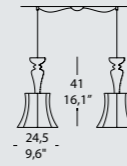

VINTAGE GLASS SO 2 CAMPANA

2 x MAX 53W E27 alo. ENERGY SAVER
o/or
2 x MAX 8W E27 LED
CE F IP20 1 EAC

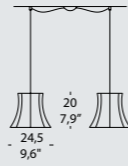

VINTAGE SO 2 CAMPANA

2 x MAX 53W E27 alo. ENERGY SAVER
o/or
2 x MAX 8W E27 LED
CE F IP20 1 EAC

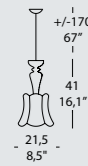

VINTAGE GLASS SO 1 BAROCCO

1 x MAX 53W E27 alo. ENERGY SAVER
o/or
1 x MAX 8W E27 LED
CE F IP20 1 EAC

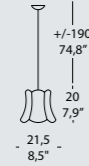

VINTAGE SO 1 BAROCCO

1 x MAX 53W E27 alo. ENERGY SAVER
o/or
1 x MAX 8W E27 LED
CE F IP20 1 EAC

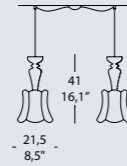

VINTAGE GLASS SO 2 BAROCCO

2 x MAX 53W E27 alo. ENERGY SAVER
o/or
2 x MAX 8W E27 LED
CE F IP20 1 EAC

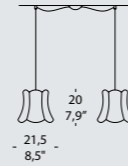

VINTAGE SO 2 BAROCCO

2 x MAX 53W E27 alo. ENERGY SAVER
o/or
2 x MAX 8W E27 LED
CE F IP20 1 EAC

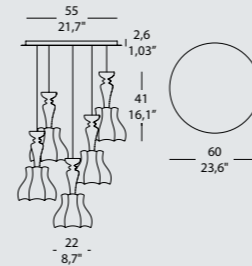

VINTAGE GLASS SO 5 PAGODA

5 x MAX 53W E27 alo. ENERGY SAVER
o/or
5 x MAX 8W E27 LED
CE F IP20 1 EAC

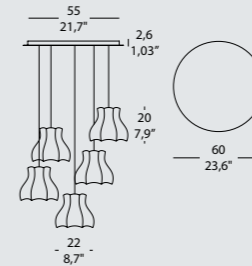

VINTAGE SO 5 PAGODA

5 x MAX 53W E27 alo. ENERGY SAVER
o/or
5 x MAX 8W E27 LED
CE F IP20 1 EAC

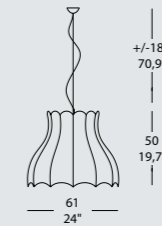

VINTAGE SO 60 PAGODA

1 x MAX 105W E27 alo. ENERGY SAVER
o/or
1 x MAX 21W E27 LED
CE F IP20 1 EAC

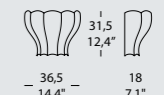

VINTAGE PA PAGODA

1 x MAX 70W E27 alo. ENERGY SAVER
o/or
1 x MAX 12W E27 LED
CE F IP20 1 EAC

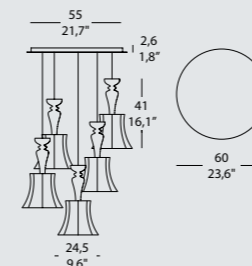

VINTAGE GLASS SO 5 CAMPANA

5 x MAX 53W E27 alo. ENERGY SAVER
o/or
5 x MAX 8W E27 LED
CE F IP20 1 EAC

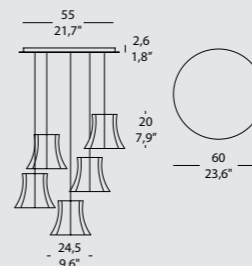

VINTAGE SO 5 CAMPANA

5 x MAX 53W E27 alo. ENERGY SAVER
o/or
5 x MAX 8W E27 LED
CE F IP20 1 EAC

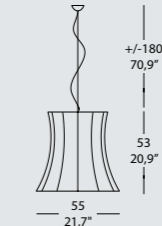

VINTAGE SO 55 CAMPANA

1 x MAX 105W E27 alo. ENERGY SAVER
o/or
1 x MAX 21W E27 LED
CE F IP20 1 EAC

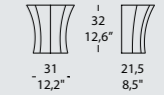

VINTAGE PA CAMPANA

1 x MAX 70W E27 alo. ENERGY SAVER
o/or
1 x MAX 12W E27 LED
CE F IP20 1 EAC

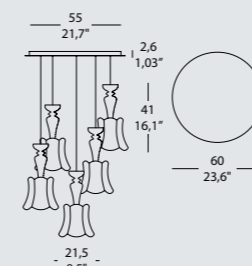

VINTAGE GLASS SO 5 BAROCCO

5 x MAX 53W E27 alo. ENERGY SAVER
o/or
5 x MAX 8W E27 LED
CE F IP20 1 EAC

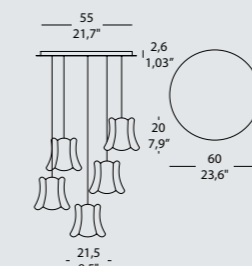

VINTAGE SO 5 BAROCCO

5 x MAX 53W E27 alo. ENERGY SAVER
o/or
5 x MAX 8W E27 LED
CE F IP20 1 EAC

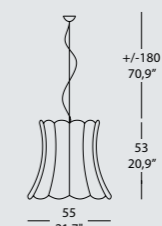

VINTAGE SO 55 BAROCCO

1 x MAX 105W E27 alo. ENERGY SAVER
o/or
1 x MAX 21W E27 LED
CE F IP20 1 EAC

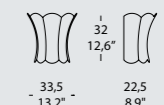

VINTAGE PA BAROCCO

1 x MAX 70W E27 alo. ENERGY SAVER
o/or
1 x MAX 12W E27 LED
CE F IP20 1 EAC



san marco

•
Romani Sacconi
Architetti Associati

L'anima di Venezia
che illumina i nostri tempi.

The soul of Venice
illuminates our time.



San Marco_ESEMPIO DI COMPOSIZIONE / EXAMPLE OF COMPOSITION





san marco

technical data

Un omaggio a Venezia, alla sua bellezza e alla sua arte vetraria. La collezione di lampade San Marco è una riedizione del classico chandelier Veneziano, qui destrutturato e solo riecheggiato dall'accostamento di semplici globi vitrei di diverso diametro, irrigiditi in successioni modulari con caratteristica goccia pendente. Sono proprio queste concatenazioni lineari a rimandare all'omonima piazza SAN MARCO e alle tondeggianti forme tracciate nello sky-line dalle cupole e dalla facciata della Basilica. La definizione dei 3 modelli base in vetro soffiato "torcion", ciascuno dotato di un proprio punto luce e di una propria sequenza-estensione, permette di allestire infinite composizioni multiple, per un prodotto contemporaneo e di facile personalizzazione.

Un hommage à Venise, à sa beauté et à son art verrier. La collection de lampes San Marco est une réédition du chandelier classique Vénitien, déstructuré ici et évoqué par l'assortiment de simples boules en verre de différents diamètres, raidis en successions modulaires avec le pendentif caractéristique en forme de goutte. Ce sont justement ces enchaînements linéaires qui renvoient à la place SAINT-MARC du même nom et aux formes arrondies tracées dans le sky-line par les coupoles et la façade de la Basilique. La définition des 3 modèles de base en verre soufflé "torcion", muni chacun d'un point lumineux propre et d'une propre séquence-extension, permet d'aménager d'infinies compositions multiples, pour un produit contemporain et facile à personnaliser.

An homage to Venice, to its beauty and the glass-making. The San Marco collection of lamps is a de-structured restyle of the classic Venetian chandelier where simple glass globes of various sizes are matched with a modular arrangement of glass pendants. The aligned arrangements recall the rounded domes and features of the facade of SAINT MARK'S basilica and the square of the same name. The 3 basic models in "torcion" blown glass - each equipped with own bulb and sequence-extension - are easy to customize with an infinite variety of arrangements that let you create your personal contemporary style.

Un homenaje a Venecia, a su belleza y a su arte del vidrio. La colección de lámparas San Marco es una reelaboración de la clásica araña veneciana, que se ha desestructurado para volver a surgir mediante la combinación de simples bolas de cristal de diferentes diámetros, combinadas en sucesiones de módulos con una característica gota colgante. Son exactamente estas concatenaciones lineales las que evocan la homónima plaza SAN MARCO y las formas redondeadas trazadas en la silueta por las cúpulas y fachadas de la Basilica. La definición de los tres modelos básicos de vidrio soplado "torcion", cada uno dotado con un punto de luz y con su secuencia-extension, permite realizar infinitas composiciones múltiples, para un producto contemporáneo y de fácil personalización.

Ein Tribut an die Stadt Venedig, ihre Schönheit und ihre Glaskunst. Die Lampenkollektion San Marco ist eine Neuaufgabe des klassischen venezianischen Kerzenständers, frei strukturiert und in Anordnung einfacher Glaskugeln verschiedener Durchmesser, die hängend als Tropfen angebracht sind. Genau diese Verkettungen sind es, die an den gleichnamigen Platz SAN MARCO und an die rundlichen Formen der Kuppeln und der Fassade der Basilika erinnern. Die Definition der 3 Basismodelle aus geblasenem "Torcion"-Glas, jedes mit einer eigenen Lichtquelle und Sequenz ausgestattet, ermöglicht unzählige und vielfältige Zusammensetzungen für ein modernes und leicht personalisierbares Produkt.

Подарок Венеции, ее красоте и ее стеклудвному искусству. Коллекция светильников San Marco - это переиздание классического Венецианского канделябра, здесь дефрагментированного и вновь созданного сочетанием простых стеклянных шаров различных диаметров, застывших в модульной последовательности с характеристикой падающей капли. Именно эти линейные сцепления напоминают об одноименной площади SAN MARCO и об округлых формах, чертящих в небе силуэты куполов и фасада Базилики. Представлена тремя базовыми модулями из дутого стекла "torcion", каждый из которых оснащен своим источником света и имеет возможность расширения последовательности, что позволяет создавать бесконечное число композиций с использованием современного и легко персонализированного продукта.

- Struttura:** metallo cromato. **Frame:** chromed metal.
- Diffusore:** vetro soffiato nei colori: ambr, cristallo trasparente e fumè. **Diffuser:** blown glass in these colors: amber, transparent crystal and smoke grey.
- Struktur:** Metall verchromt. **Diffusor:** Geblasenes Glas in den Farben: Bernstein, Kristall transparent und rauchig.
- Structure:** métal chrome. **Diffuseur:** verre soufflé dans les coloris ambr, cristal transparent et fumè.
- Estructura:** metal cromado. **Difusor:** vidrio soplado en los colores: ámbar, cristal transparente y ahumado.
- Структура:** хромированный металл. **Рассеиватель:** дутое стекло выполнено в следующих оттенках: янтарь, прозрачный хрусталь и дымчатый.

<p>SAN MARCO SO 13A 13 x MAX 42W G9 alo. ENERGY SAVER o/or 13 x MAX 3,5W G9 LED ENERGY SAVER CE F IP 20 1 EAC</p>	<p>SAN MARCO SO 13B 13 x MAX 42W G9 alo. ENERGY SAVER o/or 13 x MAX 3,5W G9 LED ENERGY SAVER CE F IP 20 1 EAC</p>	<p>SAN MARCO SO 9 9 x MAX 42W G9 alo. ENERGY SAVER o/or 9 x MAX 3,5W G9 LED ENERGY SAVER CE F IP 20 1 EAC</p>	<p>SAN MARCO SO 7 7 x MAX 42W G9 alo. ENERGY SAVER o/or 7 x MAX 3,5W G9 LED ENERGY SAVER CE F IP 20 1 EAC</p>
--	--	--	--

<p>SAN MARCO SO 3 3 x MAX 42W G9 alo. ENERGY SAVER o/or 3 x MAX 3,5W G9 LED ENERGY SAVER CE F IP 20 1 EAC</p>	<p>SAN MARCO SO 9B 9 x MAX 42W G9 alo. ENERGY SAVER o/or 9 x MAX 3,5W G9 LED ENERGY SAVER CE F IP 20 1 EAC</p>	<p>SAN MARCO SO 5B 5 x MAX 42W G9 alo. ENERGY SAVER o/or 5 x MAX 3,5W G9 LED ENERGY SAVER CE F IP 20 1 EAC</p>
<p>SAN MARCO PA 1 1 x MAX 42W G9 alo. ENERGY SAVER o/or 1 x MAX 3,5W G9 LED ENERGY SAVER CE F IP 20 1 EAC</p>	<p>SAN MARCO SO1G S/R 1 x MAX 42W G9 alo. ENERGY SAVER o/or 1 x MAX 3,5W G9 LED ENERGY SAVER CE F IP 20 1 EAC</p>	<p>SAN MARCO SO1M S/R 1 x MAX 42W G9 alo. ENERGY SAVER o/or 1 x MAX 3,5W G9 LED ENERGY SAVER CE F IP 20 1 EAC</p>
<p>SAN MARCO CO 1 x MAX 42W G9 alo. ENERGY SAVER o/or 1 x MAX 3,5W G9 LED ENERGY SAVER CE F IP 20 1 EAC</p>	<p>SAN MARCO SO 1G 1 x MAX 42W G9 alo. ENERGY SAVER o/or 1 x MAX 3,5W G9 LED ENERGY SAVER CE F IP 20 1 EAC</p>	<p>SAN MARCO SO 1M 1 x MAX 42W G9 alo. ENERGY SAVER o/or 1 x MAX 3,5W G9 LED ENERGY SAVER CE F IP 20 1 EAC</p>
<p>SAN MARCO SO 13A 13 x MAX 42W G9 alo. ENERGY SAVER o/or 13 x MAX 3,5W G9 LED ENERGY SAVER CE F IP 20 1 EAC</p>	<p>SAN MARCO SO 13B 13 x MAX 42W G9 alo. ENERGY SAVER o/or 13 x MAX 3,5W G9 LED ENERGY SAVER CE F IP 20 1 EAC</p>	<p>SAN MARCO SO 9 9 x MAX 42W G9 alo. ENERGY SAVER o/or 9 x MAX 3,5W G9 LED ENERGY SAVER CE F IP 20 1 EAC</p>



Tutte le lampade sono costruite secondo le norme europee EN 60598-1 e con materiali approvati da vari istituti di sicurezza.
All the lamps are made according to European standards EN 60598-1 and of materials approved by various safety institutes.



Apparecchio predisposto per il montaggio su superfici infiammabili.
Fixture ready for mounting on inflammable surfaces.



Apparecchio in classe II - Apparecchio nel quale la protezione contro la scossa elettrica non si basa unicamente sull'isolamento fondamentale, ma anche sulle misure supplementari di sicurezza costituite dal doppio isolamento o dall'isolamento rinforzato. Queste misure non comportano dispositivi per la messa a terra e non dipendono dalle condizioni d'installazione.

Class II appliance - appliance in which protection against electric shock is not only based on basic insulation, but also on additional safety measures, i.e. double insulation or reinforced insulation. These measures do not involve earthing devices and do not depend on the installation conditions.



Risparmio di energia.
Energy saving.



Grado di protezione - Stabilisce un sistema per la classificazione degli apparecchi elettrici in base al grado di protezione fornito dagli involucri degli stessi.







I simboli utilizzati per indicare questo grado di protezione sono costituiti dalle lettere "IP" seguite da due cifre caratteristiche:

- la prima cifra indica la protezione contro la penetrazione dei corpi solidi e della polvere;
- la seconda cifra indica la protezione contro la penetrazione dei liquidi.

Protection level - This establishes a classification system for electric appliances based on the protection level supplied by their casing. The symbols used to indicate the level of protection are the two letters, "IP" followed by two figures.

- The first figure indicates the protection against penetration by solid bodies and dust;
- The second figure indicates the protection against penetration by liquids.

Gradi di protezione IP - Protection degrees levels (IP)

1ª cifra protezione alla penetrazione di corpi solidi. 1st figure: protection against penetration by solid bodies.		2ª cifra protezione contro la penetrazione d'acqua. 2nd figure: protection against penetration by water.	
0	Non Protetto. No protection.	0	Non Protetto. No protection.
1	Protetto da corpi solidi superiori a 50 mm. Protected against solid matter (over 50 mm.).	1	Protetto contro lo stillicidio. Protected proof fixture. 
2	Protetto da corpi solidi superiori a 12 mm. Protected against solid matter (over 12 mm.).	2	Protetto da cadute d'acqua, inclinazione di 15. Protected against water falling at 15 angle.
3	Protetto da corpi solidi superiori a 2,5 mm. Protected against solid matter (over 2,5 mm.).	3	Protetto contro la pioggia. Rain proof fixture. 
4	Protetto da corpi solidi superiori a 1 mm. Protected against solid matter (over 1 mm.).	4	Protetto contro gli spruzzi. Splash proof fixture. 
5	Protetto contro la polvere. Dust proof. 	5	Protetto contro getti d'acqua. Water jet proof. 
6	Totalmente protetto contro la polvere. Fully dust proof. 	6	Protetto contro le ondate. Wave proof.



Articoli con moduli LED: consumo ridotto, lunga durata.
Articles with LED modules: low consumption, long life.

ETICHETTE ENERGETICHE DI PRODOTTO - PRODUCT ENERGY LABELS ENERGIE-EFFIZIENZETIKETTEN DES PRODUKT - ÉTIQUETTE D'ENERGIE DU PRODUIT ETIQUETAS ENERGÉTICAS DE PRODUCTO - ЭНЕРГЕТИЧЕСКАЯ МАРКИРОВКА ПРОДУКЦИИ.

Indicano la classe di efficienza energetica delle sorgenti luminose compatibili con l'apparecchio d'illuminazione.
Indicate the class of Energy-efficiency of light sources compatible with the lighting device.

Zeigen die Klasse der Energie-Effizienz der mit dem Beleuchtungsgerät kompatiblen Lichtquellen an.

Montrent la classe du rendement d'énergie des sources lumineuses compatibles avec l'appareil d'illumination.

Indican la clase de eficiencia energética de los surgentes luminosos compatibles con el aparato de iluminación.

указывают класс энергетической эффективности источников света совместимых с осветительным устройством.



Questo dispositivo è compatibile con lampadine di classi energetiche:
Diese Leuchte ist geeignet für Leuchtmittel der Energieklassen:
This luminaire is compatible with bulbs of the energy classes:
Ce luminaire est compatible avec des ampoules des classes énergétiques:
Esta luminaria es compatible con bombillas de las clases energéticas:
Этот прибор совместим с лампочками следующих классов энергетической эффективности:

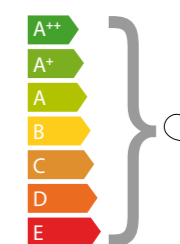

Questo dispositivo è compatibile con lampadine di classi energetiche:
Diese Leuchte ist geeignet für Leuchtmittel der Energieklassen:
This luminaire is compatible with bulbs of the energy classes:
Ce luminaire est compatible avec des ampoules des classes énergétiques:
Esta luminaria es compatible con bombillas de las clases energéticas:
Этот прибор совместим с лампочками следующих классов энергетической эффективности:



Questo dispositivo è munito di lampade a LED integrate.
Le lampade di questo dispositivo non sono sostituibili.

This luminaire contains built-in LED lamps.
The lamps cannot be changed in the luminaire.

Diese Leuchte enthält eingebaute LED-Lampen.
Die Lampen können in der Leuchte nicht ausgetauscht werden.

Ce luminaire comporte des lampes à LED intégrées.
Les lampes de ce luminaire ne peuvent pas être changées.

Esta luminaria lleva lámparas LED incorporadas.
Las lámparas de esta luminaria no son recambiables.

Этот прибор снабжен встроенным LED источником.
Лампочки этого прибора не подлежат замене.

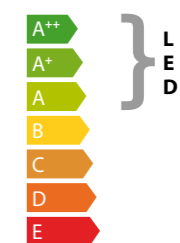

Certificazione di conformità valida per l'unione doganale EurAsEC.
Certification for Eurasian Customs Union.
Zertifizierung nach der europäischen Norm für die Eurasische Wirtschaftsgemeinschaft.
Certificat de conformité pour la Union douanière Eurasienne.
Certificado de conformidad con validez para la Unión Euroasiática.
сертификация соответствия действительна для таможенного союза ЕврАзЭС

DIRETTIVA EUP - ENERGY SAVER

Il regolamento comunitario 244/2009 del 18 marzo 2009 prevede l'uscita di produzione delle lampadine a incandescenza in 6 fasi successive, dal 1° settembre 2009 al 1° settembre 2016.

In ottemperanza a tale regolamento, si è reso necessaria l'implementazione nel nostro catalogo e listino delle indicazioni di lampadine di nuova generazione (indicate dal marchio ENERGY SAVER).

Tali lampadine consentono i seguenti benefici:

- minore consumo di energia elettrica (- 30%)
- maggiore durata delle ore di vita
- flusso luminoso costante per tutta la durata di vita della lampadina
- minore produzione di calore

EUP REGULATION- ENERGY SAVER

According to the commission regulation (EC) No 244/2009 dated 18th March 2009, incandescent light-bulbs will be removed from the market in 6 steps from 1st September 2001 to 1st September 2016.

Therefore, in compliance with this regulation, the new generation light-bulbs will be indicated in our catalogue and price list as ENERGY SAVER.

These light-bulbs have the following benefits:

- lower consumption of electric power (-30%)
- longer duration
- constant luminous flux
- less heat emission

DIRECTIVE EUP – ENERGY SAVER

Le règlement CE nr. 244/2009 du 18 mars 2009 prévoit que, en 6 phases successives du 1er septembre 2009 jusqu'au 1er septembre 2016, les lampes à incandescence ne seront plus produites.

Conformément a ce règlement, dans notre catalogue ainsi que dans notre tarif seront données les indications sur les lampes économiques de nouvelle generation (indiquées avec le marque ENERGY SAVER).

Ces ampoules donnent les avantages suivants:

- Moindre consommation d'électricité (- 30%)
- Durée de vie plus longue
- Flux lumineux constant pour toute la durée de vie de l'ampoule
- Moindre production de chaleur

RICHTLINIE EUP – ENERGY SAVER

Nach der EU Verordnung Nr. 244/2009 vom 18. März 2009, von 1. September 2009 bis 1. September 2016 in 6 folgenden Phasen, werden die Standardglühlampen nicht mehr weiter hergestellt.

Dieser Verordnung gemäß, werden die Anzeigen über die Energiesparlampen der neuen Generation (gekennzeichnet mit dem Zeichen ENERGY SAVER) in unserem Katalog sowie in unserer Preislisten mitgegeben.

Diese Energiesparlampen bieten folgende Vorteile an:

- weniger an Leistung aufnehmen (- 30%)
- längere Lebensdauer
- regelmäßige Lichtstrom während der ganzen Lebensdauer
- weniger Hitze

REGLAMENTO EUP- ENERGY SAVING

Según el reglamento comunitario 244/2009 aprobado en fecha 18 marzo 2009, las bombillas incandescentes saldrán gradualmente de producción en 6 fases desde el 1 de septiembre 2009 hasta el 1 de septiembre 2016. En conformidad con esta norma, ha sido necesario añadir en nuestro catálogo y tarifa indicaciones de las bombillas de nueva generación (señaladas como ENERGY SAVING)

Los beneficios de estas bombillas son los siguientes:

- menor consumo de energía eléctrica (-30%)
- mayor duración
- flujo luminoso constante
- menor producción de calor

ЕВРОПЕЙСКАЯ ПРОГРАММА ПО ЭНЕРГОСБЕРЕЖЕНИЮ

Согласно постановлению комиссии (ЕС) № 244/2009 от 18.03.2009, производство лампочек накаливания будет прекращаться в 6 этапов с 01.09.2001 до 01.09.2016.

В соответствии с этим постановлением, лампочки нового поколения будут обозначены в нашем каталоге и прейскуранте как ЭНЕРГОСБЕРЕГАЮЩИЕ.

Особенности энергосберегающих лампочек:

- низкое потребление электроэнергии (до 30%)
- более продолжительный срок службы
- постоянный люминесцентный поток
- низкая температура нагрева

LUCI ITALIANE SRL, ADERISCE AL CONSORZIO ECOR'IT (MILANO – ITALIA)**RAEE – DIRETTIVA 2002/96/CE, 2003/108/CE, RIFIUTI DI APPARECCHI ELETTRICI ED ELETTRONICI.**

La direttiva valida su tutto il territorio dell'Unione Europea definisce una serie di misure allo scopo di prevenire la produzione di rifiuti di apparecchiature elettriche ed elettroniche; di promuovere il riuso, il riciclo ed altre forme di recupero di queste tipologie di rifiuti; di limitare i rischi di impatto ambientale derivanti dal trattamento e dallo smaltimento dei rifiuti in questione; di armonizzare le misure nazionali di gestione dei rifiuti elettrici ed elettronici. Gli apparecchi di illuminazione marcati con l'apposito simbolo del cassonetto barrato  sono soggetti a raccolta differenziata e separata dal resto dei rifiuti urbani. Per la restituzione di un apparecchio dimesso, occorre servirsi dei sistemi di raccolta e restituzione messi a disposizione nei singoli paesi di utilizzo. RoHS – DIRETTIVA 2002/95/CE (Restriction of the use of certain Hazardous Substances in electrical and electronic equipment). Direttiva Europea che limita l'utilizzo di alcune sostanze pericolose come: piombo, cadmio, mercurio, cromo esavalente, bifenili polibromurati PBB, etere di difenile polibromurato PBDE. A partire dal 1 luglio 2006, tali sostanze non possono più essere impiegate nei prodotti elettrici ed elettronici, salvo deroghe su alcune applicazioni.

LUCI ITALIANE SRL, JOINS THE ASSOCIATION ECOR'IT (MILANO – ITALY)**WEEE – DIRECTIVE 2002/96/CE, 2003/108/CE, WASTE ELECTRICAL AND ELECTRONIC EQUIPMENT.**

This European Directive, applicable throughout the European Union, determines the precautions in order to prevent the production of waste electrical and electronic equipment; to promote the re-use, the recycle and other forms of reutilization of this kind of waste; to restrict the risk of impact on the environment as a result of the treatment and disposal of these equipments; to harmonize national measures of managing waste electrical and electronic equipment. Equipment marked with proper symbol of crossed rubbish container  may not be disposed of together with household rubbish. Waste equipment has to be returned through the waste collection systems available in every single country.

RoHS – DIRECTIVE 2002/95/CE (Restriction of the use of certain Hazardous Substances in electrical and electronic equipment). The European Directive restricts the use of some dangerous substances such as lead, cadmium, mercury, hexavalent chromium, polybrominated biphenyls PBB, polybrominated diphenyl ethers PBDE. Starting from July 1st 2006 such substances must not be used anymore in electrical and electronic equipment, apart exceptions on specific applications.

LUCI ITALIANE SRL, ADHERE A L'ASSOCIATION ECOR'IT (MILANO – ITALIE)**WEEE – DIRECTIVE 2002/96/CE, 2003/108/CE, WASTE ELECTRICAL AND ELECTRONIC EQUIPMENT.**

La directive, valable sur tout le territoire de l'Union Européenne, établi des mesures au fin d'éviter la production de déchets d'équipements électriques et électroniques, d'encourager la réutilisation des équipements usagés, le recycle ainsi que les autres formes de récupération de ces typologies de déchets; de limiter les risques pour l'environnement causés par le traitement de ces déchets et par la relative élimination; d'harmoniser les dispositions nationales de gestion des déchets électriques et électroniques. Les appareils d'éclairage, marqués avec le symbole du porte-poubelle barré , sont sujet à la collecte séparée des autres déchets urbains.

Pour la restitution d'un dispositif usagé il faut se servir des systèmes de restitution et de collecte disponibles dans chaque pays d'utilisation.

RoHS – DIRECTIVE 2002/95/CE (Restriction of the use of certain Hazardous Substances in electrical and electronic equipment).

La Directive Européenne, en limitant l'utilisation des certaines substances dangereuses - comme le plomb, le cadmium, le chrome hexavalent, le polybromobiphényles PBB et le polybromodiphénylêtres PBDE - prévoit que, à partir du 1er Juillet 2006, ces substances ne doivent plus être utilisées dans les nouveaux équipements électriques et électroniques.

LUCI ITALIANE SRL, HACE PARTE DEL CONSORCIO ECOR'IT (MILANO – ITALIA)**WEEE – DIRECTIVA 2002/96/CE, 2003/108/CE, WASTE ELECTRICAL AND ELECTRONIC EQUIPMENT.**

La Directiva es valida en toda la Union Europea y señala las medidas necesarias para prevenir la producción de residuos de aparatos eléctricos y electrónicos; para promover el reutilizo, reciclo y otras formas de recupero de estas tipologias de residuos; para limitar los efectos en el medio ambiente que vienen de los tratamientos y gestion de estos residuos; para armonizar las medidas nacionales de gestion de residuos de aparatos eléctricos y electrónicos.

El equipo de iluminación marcado con símbolo de contenedor tachado  no debe eliminarse junto con la basura urbana.

Para la devolución de antiguo dispositivo utilizar los sistemas de recogida y devolución disponible in cada país.

RoHS – DIRECTIVA 2002/95/CE (Restriction of the use of certain Hazardous Substances in electrical and electronic equipment). La Directiva impone que, a partir del 1 de Julio de 2006, los nuevos aparatos eléctricos y electrónicos que se pongan en el mercado no contengan plomo, mercurio, cadmio cromo hexavalente, polibromobifenilos PBB y polibromodifeniléteres PBDE.

LUCI ITALIANE SRL, GEHÖRT DER GENOSSENSCHAFT ECOR'IT (MILANO – ITALIEN)**WEEE – RICHTLINIE 2002/96/CE, 2003/108/CE, WASTE ELECTRICAL AND ELECTRONIC EQUIPMENT.**

Die EU Richtlinie stellt die EU-weit gültigen Maßnahmen fest, um die Produktion von Elektro- und Elektronikgeräte zu verhindern, um die Wiederverwendung sowie andere Formen von Bergung zu fördern; um die Risiken gegen die Umwelt einzuschränken, die von der Entsorgung diesen Abfälle verursacht wird; um die Ländermaßnahme bez. der Entsorgung den elektrischen und elektronischen Abfälle zu übereinstimmen. Das Gerät gezeigt mit der bestimmten Kennzeichnung  muß nicht mit dem Siedlungsabfall entsorgt werden. Für die Rückgabe eines Altgeräts muss man die in jenem Land verfügbare Rückgabe- und Sammelsysteme nützen.

RoHS – RICHTLINIE 2002/95/CE (Restriction of the use of certain Hazardous Substances in electrical and electronic equipment). Die EU Richtlinie schränkt die Verwendung einigen gefährlichen Stoffe ein, wie z.B. Blei, Cadmium, sechswertiges Chrom, polybromiertes Biphenyl PBB bzw. Polybromierten Dipheylether PBDE; ab 1. Juli 2006 müssen solche Stoffe für die Herstellung von Elektro- und Elektronikgeräte nicht mehr verwendet werden.



MOROSINI
t. +39 041 5952772
f. +39 041 5956175
info@luciitaliane.com
www.morosinisrl.com

EVI STYLE
Passion for Light
t. +39 041 5951544
f. +39 041 5956175
info@luciitaliane.com
www.evistyle.com

Brands of **Luci Italiane** srl
via delle Industrie, 70
30020 Marcon (VE) - Italy

