

No. 01
exenia magazine

Exenia collection 2019/2020_

indoor & outdoor



Exenia
collection
2019/2020_
indoor & outdoor

No. 01

exenia magazine

La luce: le fasi progettuali // The light: the project phases.....	4
Portfolio	6
Indoor.....	28
Exenia indoor collection.....	30
Novità indoor // Indoor news.....	38
Outdoor.....	56
Nuovi prodotti outdoor // New outdoor products	58

**Stabilire
l'identità del
luogo, per una
progettazione
della luce
coerente e
rispettosa_**

**// To know the
identity of each
space, enabling
you with the
ability to create
a coherent
and respectful
lighting
design_**



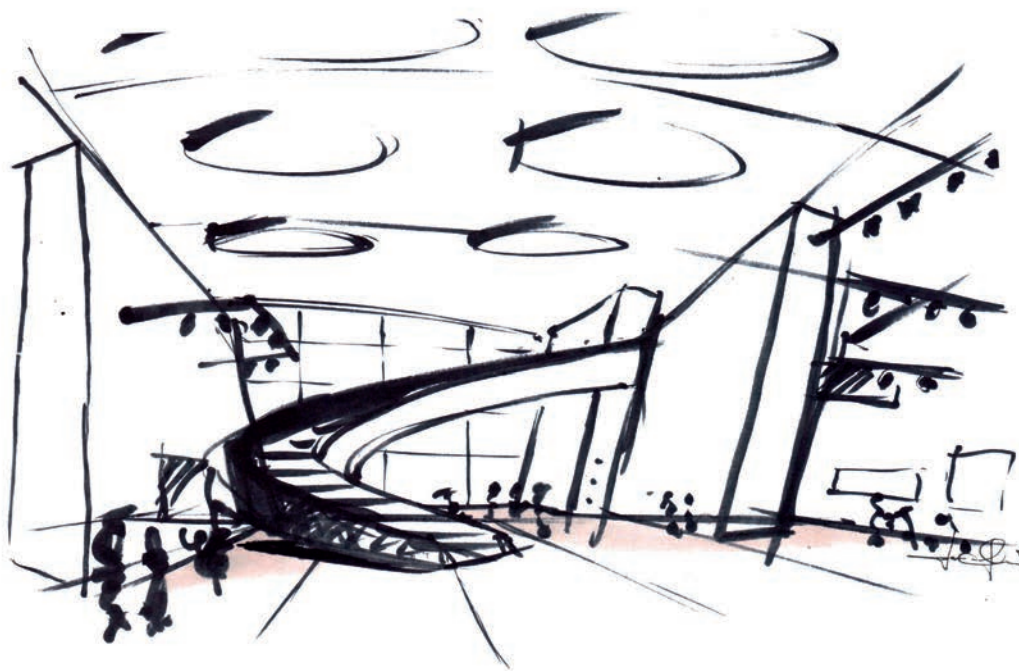

Exenia interviene acquisendo in primis gli elementi di conoscenza essenziali a stabilire l'identità del luogo, favorendo una progettazione della luce coerente e rispettosa.

Tecnologie d'avanguardia in ottica di prodotto e di soluzioni. L'obiettivo è sviluppare apparecchi "intelligenti" nel design e sofisticati nelle prestazioni, capaci di illuminare lo spazio senza inquinarlo con la sua presenza e di esaltare le diverse espressioni di utilizzo per una corretta lettura preservando l'integrità del luogo nella sua funzione.

Approccio sartoriale per valorizzare l'unicità. Non esiste un luogo o un allestimento uguale all'altro. Exenia supporta il lighting designer con strumenti di illuminazione su mi-

sura, tarati sugli obiettivi propri del progetto, le specificità del luogo e le sue destinazioni d'uso.

Abbiamo sperimentato tante volte, come gruppo, la magia di questo connubio.

// Exenia provides solutions that respect the essential elements of the identity of each space, enabling you with the ability to create a coherent and respectful lighting design.

Advanced technological solutions. Our goal is to provide luminaires that are sophisticated in design and performance; fixtures that are able to illuminate a space without disrespecting it, while also creating a presence that showcases and pays homage to the original intention of the space.



Tailored to be original. No setting is the same. Exenia provides solutions for lighting designers through highly flexible luminaires, luminaires that can be individually calibrated to the objectives of each project and the specific features of each spaces intended use. We have years of experience in orchestrating harmonies between light and space.

La luce: le fasi progettuali_ // The light: the project phases_

EXENIA_magazine



Fotografia: Creative Republic



Fotografia: Joonas Puhakka - Northern Images

Un'illuminazione rispettosa deve evidenziare l'architettura senza stravolgerla, deve riconoscere la gerarchia dei luoghi e sottolinearla con misura, aiutando le persone a vivere l'ambiente nel modo più appropriato.

La luce, detto altrimenti, deve poter essere percepita come elemento naturale dello spazio, senza "aggredire" chi guarda. Laddove possibile, dovrebbe mostrarsi nel suo divenire, non nel suo punto di origine. Il che suggerisce l'utilizzo di corpi illuminanti poco invasivi, di forma essenziale, con finiture di colore il più vicine possibile alle superfici o agli elementi su cui saranno installati e ottiche di precisione dalle elevate prestazioni.

Riferirsi a procedure standard, adattandole di volta in volta alle specificità del caso, può essere di grande aiuto. Occorre quindi definire i criteri dell'intervento progettuale, trasformare le linee guida in obiettivi concreti, ipo-

tizzare i contrasti, i livelli di illuminamento e quelli di luminanza.

Fondamentale risulterà quindi la verifica illuminotecnica, passaggio essenziale per stabilire la potenza e l'apertura dei fasci dei corpi illuminanti. La regia luminosa, infine, servirà a realizzare le scenografie specifiche più idonee.

// Respectful lighting highlights the architecture without distorting it, while also helping people to experience and enjoy the building and its context "in a new light".

In other words, artificial light, when at its best, can be perceived as a natural element of the space. Whenever possible, the source of light, like the steps of a good magic trick, should be hidden from view. The use of non-invasive, high-performance lighting fixtures, with precision optics along with minimal, soft shapes and colour finishes matched to the surface on which

they are installed, let light do its real magic.

Adapting to each specific project is an obvious strength when you're a lighting designer.

The first step of many designers is to study and analyse every detail: the existing constraints of the architecture, its context, conservatory laws, and usages are only some of the many elements to consider. To fulfil the hopes of any lighting design, illuminance and optics are three elementary key components every designer considers.

On-site luminaire testing is often done. It is here that the power and the optics choices of the lighting fixtures can truly be tried.

Portfolio: retail_

Bang & Olufsen - Helsinki | Finland

Lighting designer: DECOLight OY

Fotografia: Joonas Puhakka - Northern Images



The Schoffa - Helsinki | Finland
Lighting designer: Kaisa Lindstedt (Ramboll)
DECOLight OY



Showroom_

TERRATINTA Group - Fiorano Modenese | Italia
Progetto: Enrico Bergamini Studio, Lucetrend,
Quarta Dimensione

EXENIA_ magazine





Automotive_

CARS - Aarhus | Denmark
Lighting designer: DECOLight OY
Fotografia: Creative Republic



La luce per questo showroom è un investimento importante, per intensità e temperatura del colore.

// The light for this showroom is an important investment, for the intensity and colour temperature.



Uffici_ // Workplace_

ONDATEL - Matera | Italia

Progetto: Manca Studio

Lighting designer: Arch. Loredana Mobilia

Fotografia: Pierangelo Laterza

AREALUCE



I corpi illuminanti seguono una filosofia di linearità e modularità: il sistema Led Runner sospeso nelle aree comuni, sui tavoli e sulle scrivanie di lavoro enfatizza gli spazi e crea suggestive atmosfere luminose.

// The light fixtures are based on a philosophy of linearity and modularity: the suspended Led Runner system in the common areas and over the work tables and desks underlines spaces and creates evocative atmospheres with light.



Meeting_

TECHEDGE Group - Milano | Italia
Progetto: BBMDS

Un open-space dal feeling accogliente, che cattura lo spirito di Techedge e promuove l'incontro e lo scambio tra le persone. Il progetto dei nuovi spazi di lavoro, caratterizzati da un'alternanza di postazioni operative e aree più informali per meeting e brainstorming.

// The design of the new working spaces for this international IT company is characterised by an alternation of operative benches and areas for spontaneous meetings.



PRVA GROUP headquarters - Ljubljana | Slovenia
Progetto: Kragelj Architects
Fotografia: Davor Kralj



Istruzione_ // Culture_

LUISS Hub - Milano | Italia
Lighting designer: FABBRICANOVE
Fotografia: Paolo Stroppa
AGENZIA & GO

EXENIA_magazine





Spazio polifunzionale dedicato alla formazione, allo sviluppo d'impresa, alla creatività digitale, alla cultura dell'innovazione e all'autoimprenditorialità 4.0.

// A new multifunctional space for training, business development, digital creation, innovation culture and entrepreneurship 4.0.

L'industria_ // The factory_

Roshen chocolate factory offices - Kiev | Ukraine

Progetto: Cyrill Matias

Lighting designer: MAASS





Canteen_

ALD Automotive canteen - Roma | Italia
Progetto: GLA - Genius Loci Architettura

Il nuovo concept per la realizzazione di un'area
Staff Canteen per i dipendenti.

// The new concept for the creation of a Staff Can-
teen area for employees.



ALD Automotive canteen - Torino | Italia
Progetto: Liquidostudio+arch.Fabrizio Varvaro
Committente: Tierra S.p.A.

Nell'ex Centro Direzionale Fiat Engineering di Torino, un grande open space di 1.800 mq riconvertito nella nuova sede di Tierra.

// In the former Fiat Engineering Headquarters of Turin, a large 1.800 square meter open space converted into the new Tierra headquarters.



Hospitality_

Japs! cucina giapponese - Torino | Italia

Progetto: Lamatilde

Lighting designer: FABBRICANOVE

Fotografia: PEPE fotografia

The Birdwood - Christchurch | New Zealand

Interior designer: Nic Curragh - Objects Ltd

Lighting designer: Mark Jansen - Energylight

Fotografia: Sarah Rowlands



Il tema degli opposti: il buio e la luce creano una divisione ideale dello spazio che distingue le due modalità di fruizione Japs!, la sua doppia anima fast and slow.

// The theme of opposites: darkness and light create an ideal division of space that distinguishes the two modes of fruition Japs!, its double soul fast and slow.



Abitazioni private_ // Private home_

Casa privata - Helsinki | Finland

Lighting designer: DECOLight OY

Interior design - Fotografia: Elisa Manninen

EXENIA_magazine

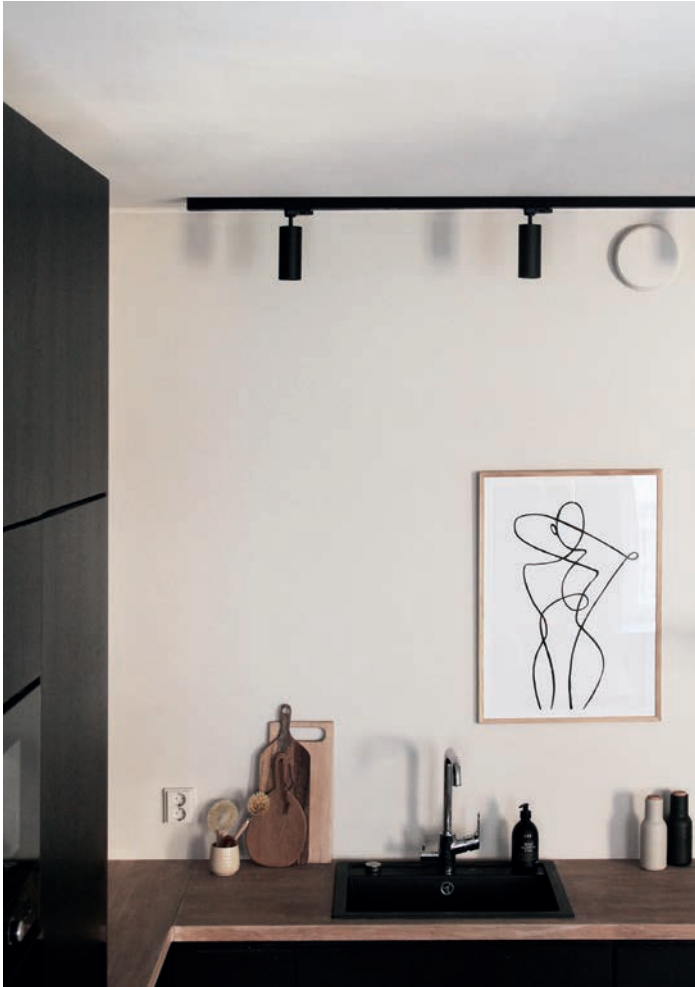

Casa privata - Helsinki | Finland
Lighting designer: DECOLight OY
Interior design - Laura Seppänen Design Agency





Casa privata Escalonada - Madrid | Spagna
Progetto: Decop design studio

Beni artistici_ // Historical context_

Tra Campo de' Fiori e Largo di Torre Argentina, a Roma, si trova uno splendido esempio di barocco romano: Palazzo Cavallerini Lazzaroni, costruito nel 1676 dall'architetto Giovanni Antonio De Rossi.

La soluzione adottata consiste in una serie di binari montati alla base delle volte su staffe metalliche

distanziatrici. Su questo sistema di supporto si sono collocati proiettori professionali a tecnologia LED.

// Between Campo de 'Fiori and Largo di Torre Argentina, in Rome, sits a splendid example of a Baroque Roman estate: The Cavallerini Lazzaroni

Palace, which was built in 1676 by the architect Giovanni Antonio De Rossi.

The lighting design consists of a series of LED projectors that were track-mounted at the base of the vaults. The tracks were mounted on metal brackets. The projectors are extremely flexible.

EXENIA_magazine



La Certosa di Calci. L'installazione studiata per la Cappella dimostra come un'adeguata progettazione della luce possa valorizzare opere del patrimonio artistico rispettandone i vincoli di tutela attraverso i più sofisticati sistemi di controllo a tecnologia LED.

// The Certosa of Calci. The lighting design illustrates how good illumination can enhance works of artistic heritage while also respecting the constraints of conservation through the use of a sophisticated LED control system.



Indoor_

Naturale o artificiale che sia, la luce illumina lo spazio, lo configura, forma e trasforma la materia modificandone la percezione. In architettura s'impone come elemento vivo e vibrante del progetto in grado di definire, enfatizzare, raccontare l'identità dei luoghi.

Oggi Exenia si contraddistingue in un panorama sconfinato come quello dell'illuminazione, grazie alla ricerca tecnologica e al design. TEC-DEC, è l'approccio attraverso il quale è possibile condensare tutte le declinazioni del fare Design Tecnologico.

// Whether natural or artificial, light illuminates space, configures it, shapes and transforms it, and ultimately modifies our perception. With architecture, light imposes itself as a vibrant element that helps define a structure, emphasising, narrating, and preserving the space. Lighting can do this in a number of ways, in a variety of different spaces.

Today, Exenia differentiates itself in the market place by creating the perfect union of stunning aesthetics and sophisticated technology within the product. We call this approach TEC-DEC. Through this design approach, Exenia has developed into a unique and iconic brand.



TRAIN YOUR MIND TO SEE THE GOOD IN EVERY SITUATION

FOCUS ON THE PROBLEM NOT THE SOLUTION

DO NOT WORRY ABOUT THE FUTURE

EXENIA_magazine

Exenia indoor collection_

2019/2020

EXENIA_magazine

Crayon box_

Exenia vanta nel suo stabilimento un sistema di verniciatura che segue tecniche sofisticate e procedure rigorose. È possibile realizzare qualsiasi colore su richiesta.

// Our paint shop, the eco-sustainable heart of our production! We can make any bespoke colour to satisfy our demanding customers.



CORTEN



EFFETTO CORTEN
RUST EFFECT BROWN



CARTA ZUCCHERO
BABY BLUE



GRIGIO CEMENTO
CONCRETE GREY



BIANCO INTONACO
PARGET WHITE
RAL. 9003 matt



BIANCO OPACO
MATT WHITE
RAL. 9003 matt



ARANCIO OPACO
MATT ORANGE



ROSSO MATTONE
BRICK RED



BIANCO LUCIDO
GLOSSY WHITE
RAL. 9003 gloss



ROSSO
RED



NERO OPACO
MATT BLACK
RAL. 9005 matt



MARRONE OPACO
MATT BROWN



BIANCO LEGNO
WHITE WOOD



LEGNO CHIARO
CLEAR WOOD



VERDE PRIMAVERA LUCIDO
GLOSS SPRING GREEN



CROMO
CROME



NERO LUCIDO
GLOSS BLACK
RAL. 9005 gloss



ROSSO LACCA
LACQUERED RED



NERO TEXTURIZZATO
MATT BLACK TEXTURED
RAL. 9005 matt



BIANCO TEXTURIZZATO
MATT WHITE TEXTURED
RAL. 9003 matt



GIALLO GRANO
CORN YELLOW



ORO TEXTURIZZATO
GOLD TEXTURED
NEW



RAME TEXTURIZZATO
COPPER TEXTURED
NEW



BRONZO TEXTURIZZATO
DARK BRONZE TEXTURED
NEW



BLU OCEANO
OCEAN BLUE
RAL. 5012 matt
NEW



ARANCIO FUOCO
FIRE ORANGE
NEW



GRIGIO ANODIZZATO
ANODIZED GREY



VERDE PRIMAVERA
SPRING GREEN

Indoor_

Sospensioni-plafoniere // Pendants-ceiling

EXENIA_magazine



Sospensioni-plafoniere // Pendants-ceiling



SPACE



STEP



STEP MAXI



STEP 3



PLURIEL MICRO



PLURIEL



PLURIEL PLUS



PLURIEL PLUS BAR



PIANO SPOT



PIANO



LINO



TRATTO



RIGHA



ROCK

NEW



KITE



MUFFIN



YOMA

NEW



FLIK



FLAT



BILUX



TOB NARROW



TOB



TOB MAXI



TOB WIDE

Indoor_

Sistemi // Systems



LED RUNNER



LED RUNNER TRIMLESS



spot



spot plus



unit LED



BRIDGE



unit LED



TRACK 48-EVO

NEW



TRACK 48



TRACK 48 TRIMLESS



glotto 48

NEW



go! 48



jam 48

NEW



plnko 48

NEW



tube 48

NEW



pluriel 48



willy 48

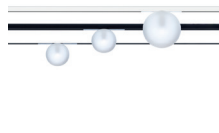

giotto 48

NEW



jam 48

NEW



zik



r2 48

NEW



spot 48



TRACK 48-RT



glotto 48-RT

NEW

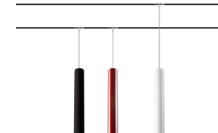

go! 48-RT



jam 48-RT

NEW



plnko 48-RT

NEW



tube 48-RT

NEW

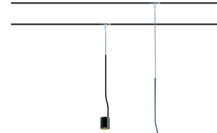

pluriel 48-RT



willy 48-RT

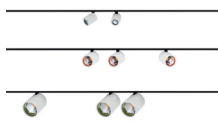

spot 48-RT

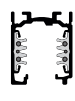

UNITRACK

NEW

Proiettori // Projectors



R2
NEW



M2



M3



M4



BILUX



CR-1



ZEN COMPACT



ZEN



NIO



PLURIEL



TRATTO



LED RUNNER



MUSEO MICRO



MUSEO MINI



MUSEO SMALL



MUSEO COMPACT



MUSEO

Indoor_

Incassati // Downlights

Opale // Opal white

Piantane // Floor lamps



BLOG SMALL

NEW



BLOG

NEW



BLOG SMALL TRIMLESS

NEW



BLOG TRIMLESS

NEW



GHOST



PIN

NEW



ORGANIC

NEW



NIO SMALL

NEW



NIO

NEW



BAT



PLURIEL MICRO



PLURIEL



PLURIEL PLUS



JAM

NEW



GIOTTO

NEW



TEDDY



IO



RONDA



ISLA



LADRILLO



ACCADEMIA

DURATA LED // LED LIFE

I LED utilizzati da Exenia S.r.l. hanno una durata stimata di 100.000 ore. Questi sono certificati LM80 e TM21. Ad eccezione dei LED 230V, che hanno una durata stimata di 40.000 ore.

// All LEDs used by Exenia S.r.l. have 100.000 hours of expected life. They are LM80 and TM21 certificated. Except the LED 230V, they have an expected life of 40.000 hours.

CARATTERISTICHE LED // LED KEY FEATURES

I prodotti Exenia S.r.l. presenti nel catalogo utilizzano sorgenti LED dei brand leader nel settore, quali: CITIZEN™, PANASONIC™, CREE™ e BRIDGELUX™.

Exenia S.r.l. inoltre garantisce che i propri LED COB sono selezionati con caratteristiche SDCM (standard deviation of colour matching/deviazione standard della corrispondenza del colore) all'interno del terzo step dell'ellisse di Mac Adam. Tuttavia rispetto ai dati di targa dichiarati dai produttori esistono pur sempre delle tolleranze dovute agli aspetti produttivi delle sorgenti LED, che comportano piccole differenze tra una sorgente e l'altra e tra un produttore ed un altro.

// The Exenia S.r.l. products in the catalogue use LED lights of the leading brand in the industry, such as CITIZEN™, PANASONIC™, CREE™ and BRIDGELUX™.

In addition, Exenia S.r.l. ensures that its LED COB are selected with SDCM features (standard deviation of colour matching) inside the third step Mac Adam ellipse.

However, compared to the plate data reported by manufacturers you should consider the tolerances that are due to LED manufacturing process. Such tolerances involve small differences between the various sources and manufactures.

COLORI FINITURE // FINISHES COLOURS

I colori degli articoli illustrati si intendono indicativi.

// The colours of the illustrated articles are simply indicative of the real nuance.

⚡ I nostri prodotti in materia di sicurezza elettrica rispettano i requisiti essenziali delle direttive comunitarie 73/23 CEE - 93/68 CEE - 89/336 CEE e la marcatura è apposta sull'imballo.

// ⚡ Our products enforce the European Community Rules 73/23 CEE - 93/68 CEE - 89/336 CEE and the CE mark is printed on the packaging.

I prodotti illustrati in questo magazine sono coperti da uno o più brevetti italiani o internazionali. L'azienda promuoverà azioni legali nei confronti di eventuali imitatori.

// The products illustrated in this magazine are covered by one or more Italian or international patents. The company will take legal action against any imitators.

CONSORZIO ECOLIGHT

Exenia S.r.l. aderisce al Consorzio Ecolight costituito nel 2004 per adempiere a quanto disposto dalla Direttiva Europea 2002/96/CE-RAEE recepita nell'ordinamento giuridico italiano con il Decreto Legislativo No.151 del 25/07/2005 per la gestione, il recupero ed il trattamento delle apparecchiature elettriche ed elettroniche a fine vita, nel rispetto di tutte le normative vigenti in materia ambientale.

Exenia S.r.l. si riserva la facoltà di modificare, in qualsiasi momento e senza preavviso, le caratteristiche tecniche dei modelli illustrati.

// Exenia S.r.l. reserves the right to change, at any time and without prior warning, the technical specification of any product.

RISCHIO FOTOBIOLOGICO // PHOTOBIOLOGICAL RISK

Tutti i LED utilizzati da Exenia S.r.l. appartengono al gruppo "RG1" (rischio basso), secondo la classificazione del rischio fotobiologico della norma EN 62471:2008.

// The LED used belongs to the "RG1" (low risk) group according to the photobiological risk rating of EN 62471: 2008.

Novità indoor_ // Indoor news_

EXENIA_magazine

Suardò - Civitanove Marche | Italia
Progetto e foto: Alberto Vallesi Design Studio



Track 48 a tutta tecnologia_

// At full technology_

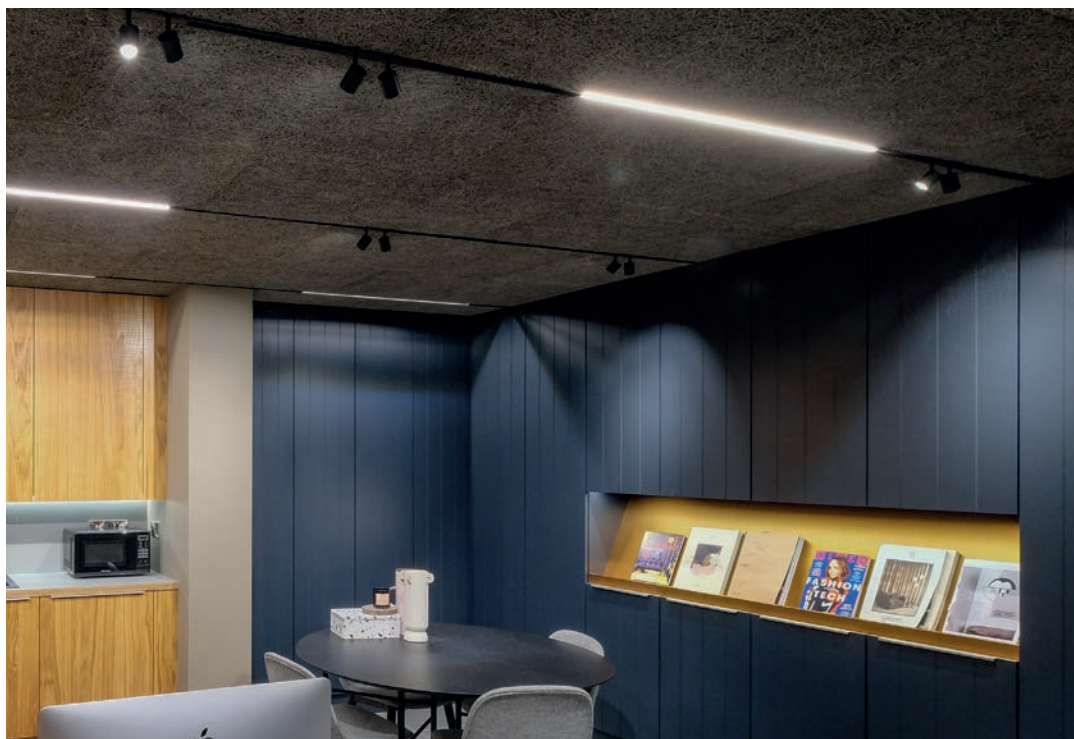

Maven Offices - Belfast | Ireland
Progetto: Lloyd Crawford - CROMA
Fotografia: Catherine and Patricia McGinnis

Il Sistema 48V di Exenia è un esempio eccellente di come la tecnologia LED possa applicarsi idealmente a una serie di apparecchi facendone degli strumenti di progettazione flessibili e performanti.

La miniaturizzazione delle componenti nulla toglie alla qualità delle ottiche, che sono anzi fra i risultati migliori della ricerca continua in innovazione in termini tanto estetici quanto funzionali. Il fine ultimo era creare un sistema universale semplice e aperto, pensato e costruito per illuminare gli spazi domestici così come un museo o un ambiente retail. L'idea "furba", in questo caso, consiste nell'aver integrato dettagli decorativi in un sistema d'ispirazione tecnica, conferendo all'insieme una nota di appeal e riconoscibilità perfettamente coerente con la filosofia Exenia.

// 48VDC System by Exenia is a perfect example of how LED technology can ideally be applied to a set of lighting fixtures, making them flexible and performing design tools.

The miniaturization of its components doesn't take anything away from optics' quality, which are indeed one of the best results of continuous research in innovation in terms of both aesthetics and function.

The ultimate goal was to create a simple and open universal system, designed and built to light up domestic spaces as well as a museum or a retail environment.

The crafty idea, in this case, consists in integrating decorative details in a technical inspiration system, giving the whole a unique character which is perfectly coherent with Exenia philosophy.

C'è una Naboo per ogni spazio, grande o piccolo che sia. Merito del suo DNA trasformista, del suo essere segno geometrico, prima ancora che corpo illuminante.

Disponibile in più diametri per adattarsi ad ambienti di dimensioni anche molto diverse, Naboo è una sospensione essenziale e impattante allo stesso tempo. Le nuovissime versioni a installazione verticale ne accentuano il dinamismo, ribaltando non solo le logiche del flusso luminoso, ma la stessa identità di un apparecchio capace di integrarsi da protagonista nell'architettura d'interni.

// There is a Naboo for every space, large or small. It's all thanks to its transforming power, its being a geometric sign besides an illuminating body.

Naboo is an essential suspension with a significant impact. It is available in several diameters to adapt to very different dimensions contexts. The brand-new vertical installation versions enhance its dynamism, reversing not only the logic of luminous flux, but the very identity of a luminaire born to integrate as a protagonist into interior architecture.



R2, forma e sostanza_

// Form and substance_

Il design del proiettore R2 è caratterizzato da un volume cavo che lo attraversa nella sua parte posteriore.

// Innovative design language, including a hole in the body of the luminaire.

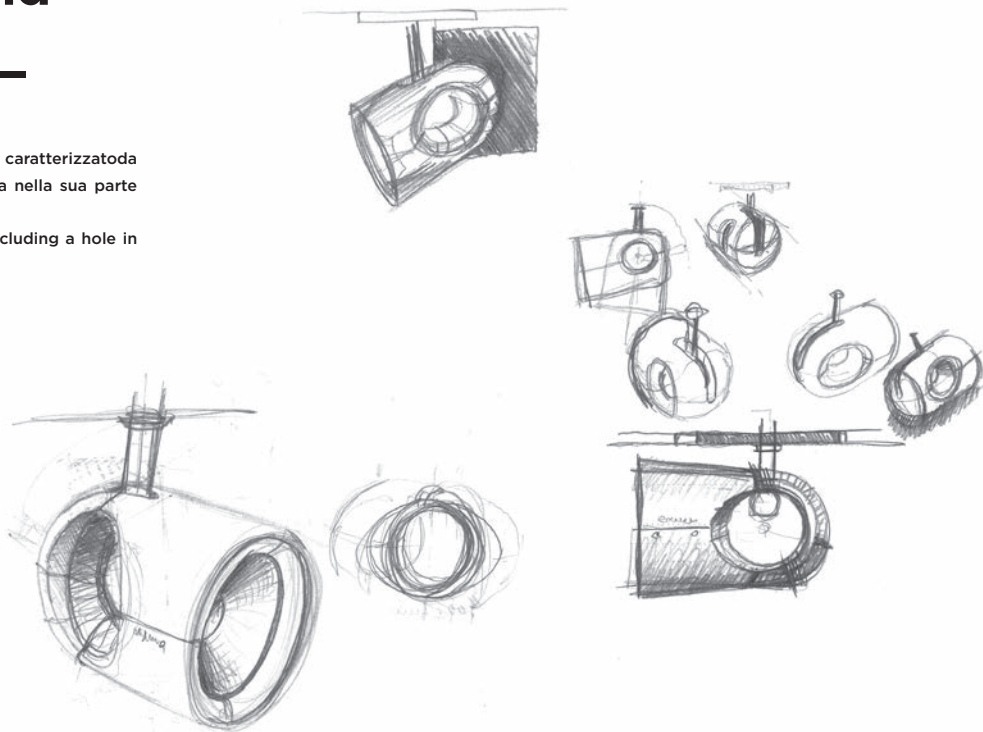

Design e performance si fondono nel proiettore R2 raggiungendo livelli inediti di sintesi. La chiave di volta è una camera di ventilazione trasversale, progettata per migliorare la dissipazione passiva del calore e il rendimento generale dell'apparecchio mantenendo dimensioni contenute.

Un concept depositato che permette di coniugare estetica e funzione diventando un segno grafico caratterizzante. Innovative ottiche in alluminio e lenti TIR a spessore ridotto garantiscono fasci controllati e un'eccellente stabilità cromatica. Lo zoom ottico a lente mobile permette inoltre di regolare l'apertura del fascio da 9° a 35° in tutte le potenze di gamma.

Altro plus di R2 è il suo eclettismo, la possibilità di configurarlo a piacere sfruttando l'ampia gamma di finiture disponibili. Se le versioni in tinta unita esaltano il suo design compatto permettendo di mimetizzarlo nell'ambiente, le combinazioni a tinte vivaci possono farne un estroso complemento di arredo, riconoscibile anche al buio grazie alle ghiera accessorie che si accendono di colore.

// Design and performance merge into R2 projector, achieving new levels of synthesis. The key is a transverse ventilation chamber designed to improve passive heat dissipation and overall performance of the fixture while maintaining compact sizes. It is a registered concept that allows to combine aesthetics and function becoming a characteristic graphic sign.

Innovative aluminum optics and reduced thickness TIR-lenses guarantee controlled light beams and excellent chromatic stability. The optical zoom with mobile lens also allows the beam to be adjusted from 9° to 35° in all the powers of the range.

Eclecticism is another plus of R2, the possibility to change it at will thanks to the wide choice of available finishes. Solid colour versions enhance its compact design and make R2 become one with the environment, whilst bright colour combinations can make it an original piece of furniture. You can appreciate it even in the dark thanks to accessory rings brightening in colour.

12/17/25/31W - 230V

12/17/25W - 48V

CRI 85 - 3000K

CRI 95 - 2700/3000/4000K

SPOT/MEDIUM/WIDE

ON-OFF / DALI

IP₂₀

● ● ● body

 ● ● ● eye - arm

 ● ● ● ring



Incassati colore, mimesi e comfort_ // Downlights colour, mimesis and comfort_

Questa è la nostra visione, apportare divertimento e colore nelle installazioni ad incasso.

// It is our vision to put the 'fun' back into downlighting and to add a splash of colour.

Dimensioni ridotte e prestazioni sorprendenti per le linee di incassati Pin, Blog e Nio.

A prima vista elementare, **Pin** è in realtà un downlight sofisticato, intelligente perché facilissimo da installare e versatile perché capace di mostrarsi oppure di scomparire a seconda della finitura scelta. Se il colore è il suo linguaggio naturale - con i nuovi classici bronzo, rame e oro a completare la gamma - la sua vera forza è il mimetismo, esaltato da inedite **forme organiche**. Tra i suoi plus anche il grado di protezione IP45 e un livello eccellente di comfort visivo.

Non è da meno la linea **Blog**, che propone incassati orientabili, fissi e trimless in due diverse dimensioni ugualmente contenute. La forma morbida quadrangolare e le ottiche arretrate sono elementi fortemente caratterizzanti, così come la possibilità di personalizzare ogni versione con cover colorate in PMMA traslucido divertenti anche a luce spenta.

La famiglia **Nio**, infine, si arricchisce con le versioni a incasso grandi e piccole, che vanno a unirsi a quelle orientabili.

Tutte queste famiglie di prodotto sono compatibili con il controllo Bluetooth per le versioni Dali.

// Small size and astonishing performance for for Pin , Blog and Nio downlight families.

At first glance, **Pin** is basic, elementary. It is a sophisticated fixture, actually: clever as it's extremely easy to be installed, and versatile because it can show itself or disappear depending on the chosen finish. Colour is its natural language - with the new classics bronze, copper and gold to complete the range - but its true strength is mimicry, enhanced by **unusual organic shapes**. Other plus- es are a protection degree IP45 and the great level of visual comfort.

The **Blog** line is no exception, with its range of adjustable, fixed and trimless recessed fixtures in two different sizes, both of which reduced. You can recognize it from the softly quadrangular shape and backward optics, as well as from the possibility to customize each version with colourful translucent PMMA covers which are fun even with the light off.

And last but not least, the **Nio** family of products is now complete with the new fixed downlight range.

All these families are now also available with Bluetooth control.

1,2W 350mA - PIN MICRO
4,2W 250mA - PIN SMALL
10W 300mA - PIN MEDIUM/ORGANIC
CRI 85 - 3000K
CRI 95 - 2700/3000/4000K
ON-OFF / DALI / PUSH / 1..10V



**Pin,
il punto
luce_
// Pin,
the light
point_**



Nio, la famiglia_

// Nio, the family_

Due proiettori di dimensioni differenti, di cui uno miniaturizzato e di grande potenza, permettono flessibilità e la migliore integrazione nel contesto architettonico. I corpi illuminanti si arricchiscono di appeal estetico grazie agli anelli colorati, tipici della filosofia del marchio.

// The Nio range includes a larger, high power fitting as well as a miniaturized version which makes this range an ideal tool for both large and small-scale architectures. The coloured ring is an aesthetic detail that can make the luminaire 'pop' or blend into the design around it.

EXENIA_magazine



13W 350mA / 18W 500mA - NIO SMALL
SPOT/MEDIUM/LARGE

18W 500mA - 53W 1400mA - NIO
SPOT/MEDIUM/WIDE

CRI 85 - 3000K

CRI 95 - 2700/3000/4000K

ON-OFF / DALI-PUSH / T. FASE

IP₂₀   

○ ● body
● ● ● ● ring



Blog, una meraviglia_

// Blog, a wonder_

"Certo qualche cosa di meraviglioso mi accade ogni qual volta bevo o mangio," disse fra sé; "vediamo dunque che cosa produrrà questo liquore. Spero che mi farà crescere di nuovo, perchè sono proprio stanca di vedermi così piccina!"

Alice nel paese delle meraviglie.

// "I know something interesting is sure to happen," she said to herself, "whenever I eat or drink anything; so I'll just see what this bottle does. I do hope it'll make me grow large again, for really I'm quite tired of being such a tiny little thing!"

Alicès Adventures in Wonderland.

EXENIA_magazine



6W 350mA - BLOG SMALL / TRIMLESS

MEDIUM/LARGE/WIDE

13W 350mA - BLOG / TRIMLESS

SPOT/MEDIUM/LARGE

CRI 85 - 3000K

CRI 95 - 2700/3000/4000K

ON-OFF / DALI / PUSH-1..10V / T. FASE

IP₂₀   

  body
     ring



Giotto, semplicemente perfetto_ // Giotto, simply perfect_

Distribuzione omnidirezionale ottenuta dalla sfera
in vetro acidato disponibile nelle misure di 100mm
e 150mm.

// Omni-directional light distribution, made from
frosted glass and available with a diameter of
100mm or 150mm.

EXENIA_magazine



6W - GIOTTO
CRI 85 - 3000K
CRI 95 - 2700/3000/4000K
ON-OFF
IP₂₀  
 cover



Jam nudo o vestito_ // Jam naked or dressed_

È possibile abbinare una cover come accessorio decorativo, oppure ottenere una distribuzione omnidirezionale senza.

// Jam cylindrical element with omni-directional light distribution, made from frosted glass.

EXENIA_magazine



6W - JAM

CRI 85 - 3000K

CRI 95 - 2700/3000/4000K

ON-OFF

IP₄₀  

 cover



Pinko, forma e colore_ // Shape and colour_

È possibile ottenere combinazioni di colore uniche, grazie all'ampia scelta di colori del corpo e dell'anello.

// Unique colour combinations can be created for this luminaire with the wide choice of inner bezel and housing finishes.

EXENIA_magazine



6,5W - PINKO

CRI 85 - 3000K

CRI 95 - 2700/3000/4000K

ON-OFF / DALI / PUSH / 1..10V / T. FASE

IP₄₀  

 body ring



Outdoor_

L'essenza della funzione, il tecnico-decorativo. La nuova collezione outdoor di Exenia si organizza in queste due macro-famiglie, mantenendo l'ispirazione giovane ed eclettica che ha portato l'azienda ad affermarsi nell'illuminazione d'interni con apparecchi per luoghi di culto e spazi residenziali, hospitality e ambienti retail.

L'exterior lighting rappresenta per Exenia un'evoluzione naturale, l'apertura a un mercato sempre più esigente e sensibile al patrimonio di tecnologia ed equilibrio formale di cui il brand è portatore.

// Dec-tech and the essence of function. The new Exenia outdoor collection is declined in these two macro-families, maintaining the young and eclectic inspiration that allowed the company to succeed in interior lighting with appliances for places of worship and residential spaces, hospitality and retail.

For Exenia, exterior lighting is a natural evolution, the interest in an increasingly demanding market that is sensitive to the mix of technology and formal equilibrium which the brand is the witness of.



Nuovi prodotti outdoor_ // New outdoor products_

EXENIA_magazine

Fotografia: Josh Wilburne - Unsplash



Crayon box_

La serie dei prodotti outdoor di Exenia sono disponibili in una gamma di finiture naturali che consentiranno agli apparecchi di integrarsi perfettamente nel loro habitat naturale o architeturale. Queste finiture sono realizzate con vernici a polvere appli-

cate elettrostaticamente, adatte per l'uso in applicazioni esterne.

// Exenia outdoor luminaires come in a range of newly created natural textured finishes that will

allow the luminaires to blend seamlessly into their natural habitat. These finishes are electrostatically applied powder coat finishes, suitable for use in exterior applications.

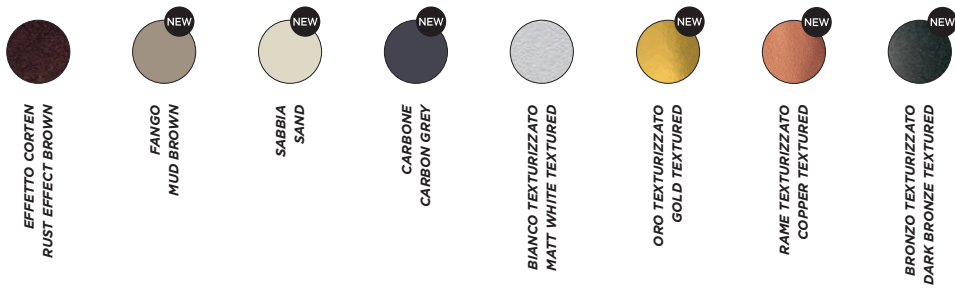

Colori x ESTERNI OPACHI / RUVIDI

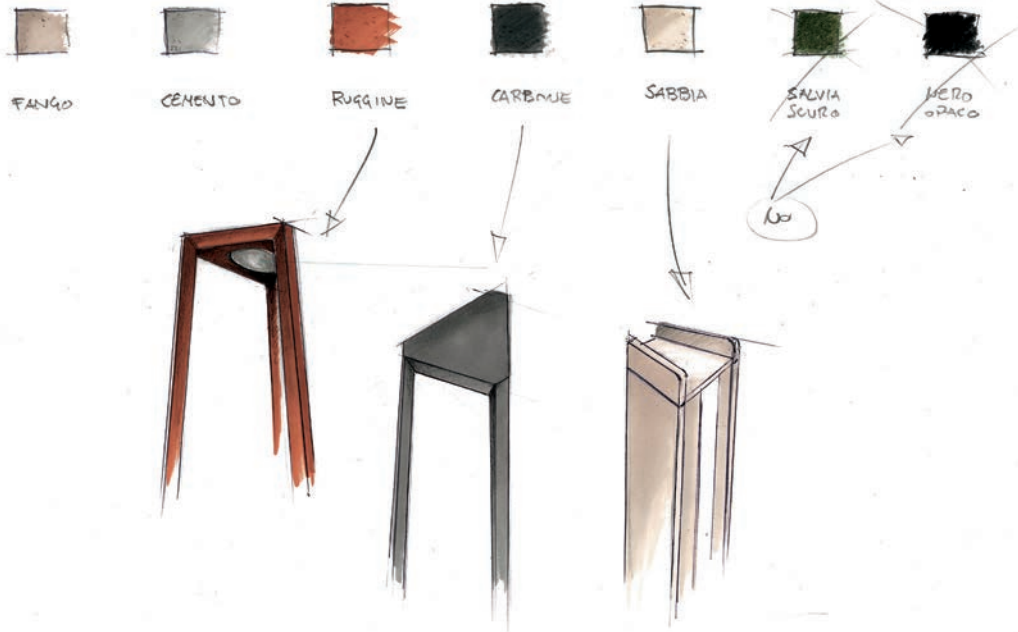



**Fleur a
fior di luce _
// Light flowers_**



Rendere aggraziato un prodotto a vocazione tecnica è una sfida intrigante. Exenia questa sfida l'ha vinta con Fleur, romantica creazione nel nome e nell'aspetto, irresistibile in ogni possibile accezione. Piegato, torto o allungato, Fleur non si scompone mai. Merito di tecnologie di rado associate all'illuminazione, che gli ingegneri Exenia hanno avuto invece l'intuito di applicare allo sviluppo di un apparecchio originale nel concept, attraente allo sguardo e divertente nelle sue molteplici composizioni.

// Making a basically technical product graceful is an intriguing challenge. Exenia won this challenge with Fleur, a romantic creation by name and by appearance, irresistible in every meaning of the word. Folded, twisted or stretched, Fleur never breaks down. This is due to technologies seldom associated with lighting, which Exenia engineers happily applied to the development of an eye-catching luminaire, original in the concept and fun in its multiple compositions.

1,2W - FLEUR
CRI 85 - 2700/3000/4000K
ON-OFF
IP₆₅ $\frac{1}{2}$
● ● ● ● body



Wolf & Cactus doppia pelle_ // Double skin_



Miniaturizzato e supertecnologico, Wolf è il proiettore di Exenia concepito per soddisfare le richieste più insolite. Una soluzione versatile capace di combinare doti di robustezza e solidità - e un grado di protezione IP65 - con le qualità estetiche e funzionali proprie di un apparecchio da interni.

I numerosi accessori a disposizione e il vasto range di ottiche (da 15° a 50°) e temperature colore (2700K, 3000K e 4000K) ne fanno uno strumento di progettazione sofisticato nelle possibilità, semplice nell'utilizzo.

Da proiettore a bollard. Montato a palo, il proiettore Wolf diventa Cactus, soluzione di illuminazione che sembra elementare e non lo è. Ogni dettaglio è infatti il risultato di uno studio attentissimo - dal posizionamento libero sul palo alla possibilità di montare fino a tre corpi illuminanti, dal robusto ancoraggio a terra, alla doppia emissione con inserimento di strip LED sul retro.

// A miniaturized and super-technological projector. Designed to meet the most unusual requests, Wolf by Exenia is a versatile luminaire capable of combining strength and resilience - and an IP65 degree of protection - with the aesthetic and functional qualities of an indoor lighting fixture.

The numerous accessories and the wide range of optics (from 15° to 50°) and colour temperatures (2700K, 3000K and 4000K) make it a sophisticated design tool very easy to be used. From projector to bollard. Mounted on a pole, Wolf projector becomes Cactus, a lighting solution that seems elementary and is not. Every detail is the result of careful study, in fact - from free positioning on the pole to the possibility of mounting up to three fixtures, from the sturdy anchorage to the ground, to the double emission with insertion of LED strips on the back.

CACTUS



5/13W - WOLF
CRI 85 - 3000K
CRI 95 - 2700/3000/4000K
SPOT/FLOOD/MEDIUM/WIDE
ON-OFF
IP₆₅ ≡
● ● ● ● ● body
○ ● ● ● ● ring

5/13W - CACTUS h = 600mm, 1000mm e 2000mm
CRI 85 - 3000K
CRI 95 - 2700/3000/4000K
SPOT/FLOOD/MEDIUM/WIDE
ON-OFF
IP₆₅ ≡
● ● ● ● ● body
○ ● ● ● ● ring

Play, un gioco di composizione_ // Composition game_

Si chiama Play l'appliche di Exenia capace di inserirsi in ogni progetto con la necessaria discrezione. Di scomparire, se occorre, grazie a finiture naturali e a sorgenti per luce diretta o indiretta - decide quali il progettista - posizionate per garantire il massimo del comfort visivo in ogni condizione.

Play è un prodotto e tanti prodotti insieme, grazie ad accessori come lo snoot, il visore o la lente ellittica che consente di coprire con la luce estensioni differenti. O ancora, la cover li-

neare che contiene l'apparecchio tagliando perfettamente il fascio di luce.

// The Exenia applique able to discreetly fit into any project is called Play. It can even disappear, if necessary, thanks to natural finishes and sources for direct or indirect lighting placed to ensure maximum visual comfort in all conditions. It depends from the designer.

Play is a product and many products at the same time, due to accessories such as the snoot, the visor or the el-

liptical lens that allow you to cover different extensions with light. Another accessory is the linear cover that encloses the luminaire by perfectly cutting the light beam.



Play bianco opaco texturizzato, a fianco con cover finitura effetto corten.

// Matt textured white Play, by side with rust effect brown cover.



6,7W - PLAY DIR.

2x6,7W - PLAY DIR./IND.

CRI 85 - 3000K

CRI 95 - 2700/3000/4000K

SPOT/FLOOD/MEDIUM/WIDE

ON-OFF

IP₆₅ $\frac{1}{2}$

- body
- ring
- cover

Rock into the box_

Gli oggetti preziosi, il più delle volte, sono racchiusi in una scatola piccola piccola. Il gioiello, in questo caso, è la scatola stessa, un involucro di appena 112 mm x 80 mm x 30 mm da cui si diffonde una luce morbida che seduce e non offende, perché la sorgente è volutamente arretrata. Exenia sperimenta con Rock il nude look, dando

vita a un'applicare da esterni essenziale senza compromessi, impalpabile e lieve come un battito d'ali.

// Precious things are often enclosed in a small small box. The jewel, in this case, is the box itself, a casing of just 112 mm x 80 mm x 30 mm from which a soft light spreads that seduces and

doesn't offend because the source is deliberately set back. With Rock, Exenia experiences the "nude look", giving life to an outdoor wall light which is essential without compromise, intangible and gentle as a butterfly's flap.



4,5W - ROCK
CRI 85 - 2700/3000/4000K

DIFFUSA 180°

ON-OFF

IP₆₅ $\frac{1}{2}$

● ● ● ● ● body



Trim & Mark, concentrato di valore_ // Pure value_

EXENIA_ magazine

Non tragga in inganno l'essenzialità della forma. I downlight da terra e parete Trim e Mark, coerentemente con lo stile Exenia, sono un concentrato di efficienza funzionale e versatilità stilistica, grazie a finiture colorate o di ispirazione industriale come il grigio carbone e l'effetto ruggine e all'ampia disponibilità di ottiche: spot, media, larga ed ellittica.

// The essential shape must not mislead. Trim and Mark floor and wall downlights are icons of functional efficiency and stylistic versatility in perfect line with Exenia philosophy. The range includes coloured or industrial-inspired finishes such as charcoal-gray and the rust effect, and different optics: spot, medium, wide and elliptical.

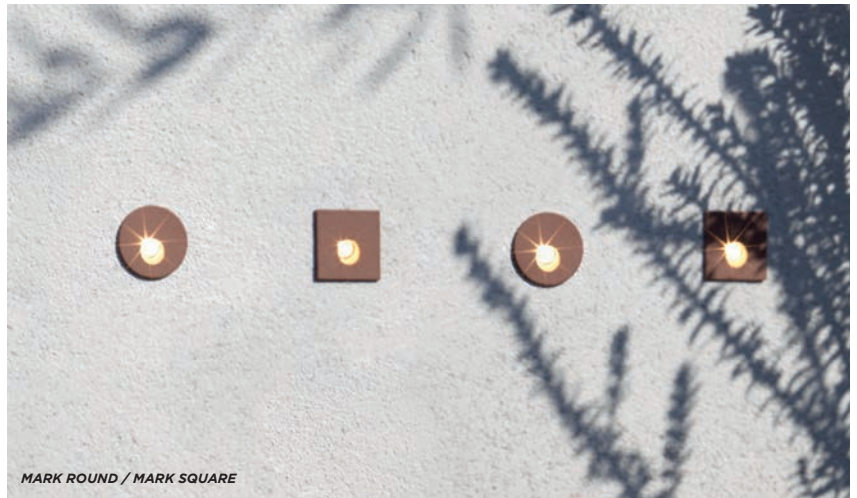

MARK ROUND / MARK SQUARE



TRIM

1,2W - MARK ROUND
1,2W - MARK SQUARE
CRI 85 - 2700/3000/4000K

DIRETTA

ON-OFF

IP₆₅

body

1,2W - TRIM

4W - TRIM NANO

CRI 85 - 2700/3000/4000K

SPOT/MEDIUM/WIDE/ELLIPSE 5°x60°

ON-OFF

IP₆₅

body

Yoma, estro su misura_ // Tailored genius_

Yoma è un plafone di piccole dimensioni per luce generale diffusa. Al suo interno batte un cuore tecnologico a LED, ma è la sua anima estrosa ad attrarre e conquistare, il suo saper essere sempre diverso e unico allo stesso tempo. Basta un anello decorativo e la luce che, attraversandolo, ne assorbe le nuances per farsi ancora più bella.

// Yoma is a small-sized ceiling light for diffused general lighting. A technological LED heart beats inside it, but it is its fanciful soul that attracts and conquers, its ability to always be different and unique at the same time. Just need a decorative ring and the light that crosses it and absorbs its nuances, thus becoming even more beautiful.



4,5/8,6W - YOMA
CRI 85 - 2700/3000/4000K
DIFFUSA
ON-OFF
IP₆₅ $\frac{\square}{\square}$
● ● ● ● ● body
● ● ● ● ● cover

CREDITS

Designer

Lorenzo Querci

Grafica e Layout

Michela Spatola
Gaia Orbignizzi

Contenuti // Contents

Beatrice Santini
Anja Stolte
Lorenzo Querci
Michela Spatola
Monica Luzzi

Foto // Photography

Le Officine S.r.l.

Stampa // Printing

Conti Tipocolor S.p.A.
Firenze | Marzo 2019

In-place photography

© Alberto Vallesi
© Creative Republic
© Catherine McGinnis
© Davor Kralj
© Elisa Manninen
© Joonas Puhakka
© Josh Wilburne
© Laura Seppänen
© Le Officine
© Paolo Stroppa
© Patricia McGinnis
© PEPE fotografia
© Pierangelo Laterza
© Sarah Rowlands
© Varvara Verbitskaya

Thanks to

Clorinda Shoes Firenze
Stefania Caramelli

© Copyright 2019
Tutti i diritti riservati Exenia S.r.l.
All rights reserved Exenia S.r.l.

exenia
part of the lumenpulse
GROUP

Exenia S.r.l.
via della Chiesa 38
50041 Calenzano
Firenze | Italia
T +39 055 54 17 54
F +39 055 54 17 575

exenia.eu
lumenpulsegroup.com

