

ITAMA  
THE  
DESIGN  
OF LIGHT

itama

A voyage  
between  
Italian art  
and design  
to discover  
the scenographic  
atmosphere  
of light  
and shadow.

**Itama**  
the Design  
of Light.

Dotini

itama  
*by Light4*







Arriving from	Status
VENICE	LANDED
VENICE	LANDED
NEW YORK	CONTACT
NEW YORK	CONTACT

*landing at the real heart  
of art, culture  
and Italian design*

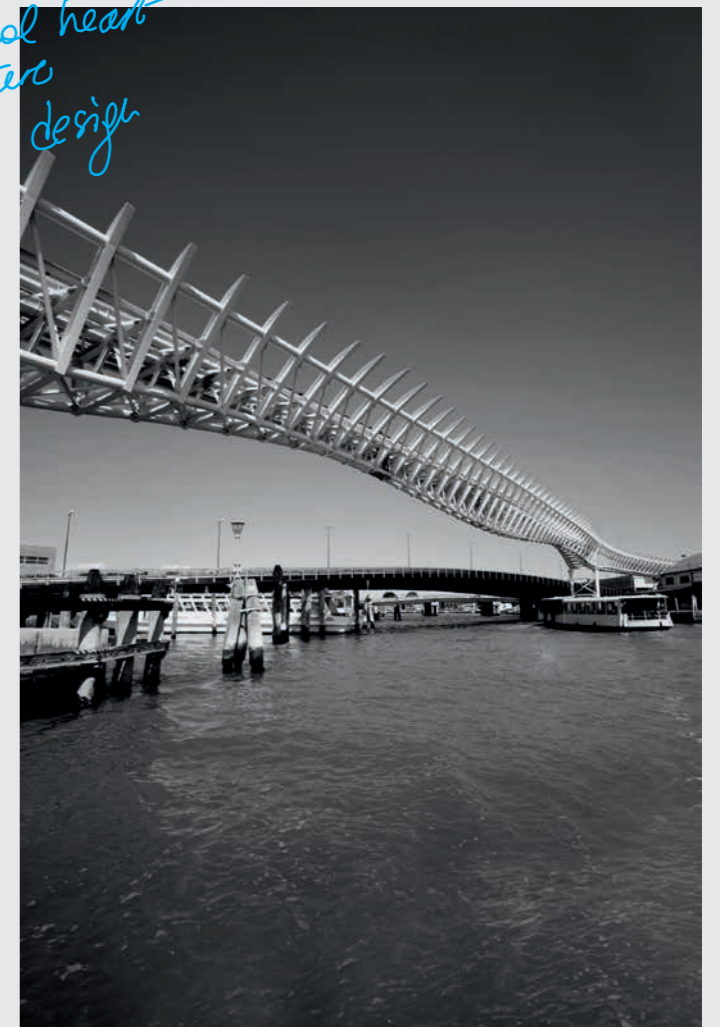



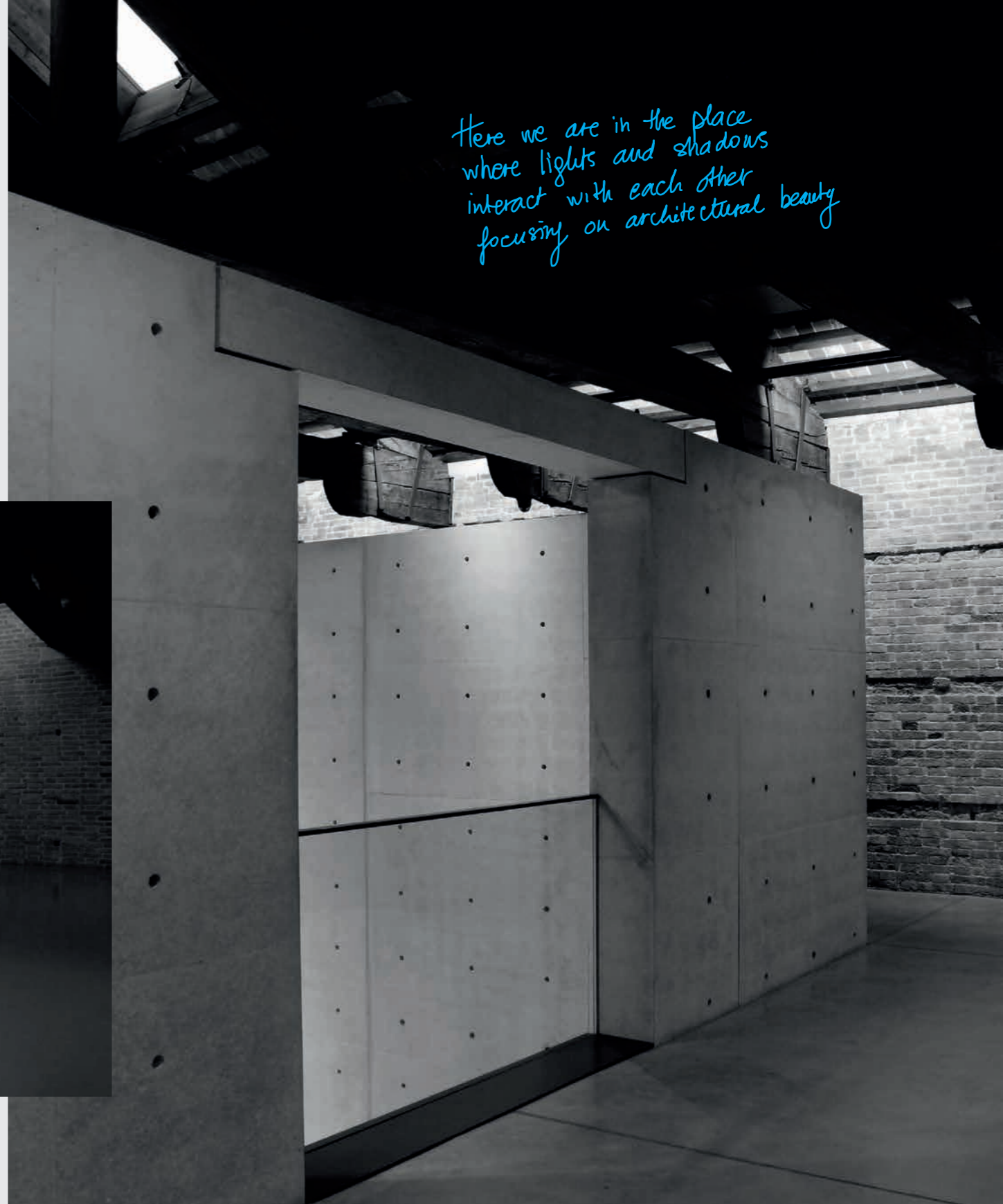

*Here we are in the place  
where lights and shadows  
interact with each other  
focusing on architectural beauty*

## The Design of Light



[En] → ITAMA is the LIGHT4 brand that distinguishes itself for the technological content and functionality of its products. Light is, in every product, the main player and all choices made are done so to value and optimise the light source. Care in choice of lightsource and the search

for utmost quality of light emission goes hand in hand with the minimal design, attention to detail and finishes of all ITAMA collections. The technical evolution of light sources allows us new possibilities in lighting design, moving the traditional boundaries a little further away. All ITAMA products are 100% made in Italy.

[It] → ITAMA è il marchio LIGHT4 che si distingue per l'aspetto tecnologico e funzionale delle sue creazioni. La luce, in ogni prodotto è protagonista e le scelte formali sono concepite solo in funzione della valorizzazione e ottimizzazione della sorgente luminosa. L'attenzione e la ricerca per quanto riguarda la qualità della luce si sposa perfettamente con il design minimale e l'attenta cura dei dettagli e finiture delle collezioni ITAMA. L'evoluzione tecnica delle sorgenti luminose consente di esplorare nuove possibilità nel campo del lighting design mettendone in discussione i parametri tradizionali. Tutti i prodotti ITAMA sono al 100% made in Italy.



[De] → ITAMA ist eine der Marken von LIGHT4, die für das technologische und funktionelle Aussehen seines Schaffens steht. Das Licht ist der Star in jedem Produkt und die Formen sind nur in Bezug auf die Weiterentwicklung und Optimierung der Lichtquelle konzipiert. Die Aufmerksamkeit und Forschung in Bezug auf die Qualität des Lichtes passt in ITAMA perfekt zu dem minimalistischen Design mit der Liebe zum Detail und Ausführungen. Die technische Entwicklung der Lichtquellen verhilft neue Möglichkeiten im Bereich der Lichtgestaltung zu erforschen und führt zur Befragung der traditionellen Parameter. Alle Produkte von ITAMA sind 100% Made in Italy.

[Ru] → Itama от LIGHT4 это бренд, выделяющийся своей технологичностью и функциональностью. Свет – это главное в каждой модели, все остальное только подчеркивает источник света. Постоянный поиск новых решений, улучшающих качество света, идеально сочетается с минималистским дизайном и вниманием к деталям и отделкам. Техническая эволюция источников света позволяет добавлять новые возможности в области дизайна освещения, не опираясь на традиционные параметры. Вся продукция Itama на 100% сделана в Италии.

[Ar] → تصميم الإضاءة

ITAMA هي الماركة من LIGHT4 أن يميز نفسه عن محتوى التكنولوجي و وظائف منتجاتها. الإضاءة في كل منتج وهو المثل الرئيسي وجميع الخيارات التي تحسن مصدر الضوء. الرعاية في اختيار مصدر الضوء والبحث عن الجودة القصوى ل انبعاث الضوء يسير متطابقة مع بساطة التصميم. تطور تقنية إنتاج مصادر الضوء يسمح لنا بتوفير إمكانيات جديدة في تصميم الإضاءة ، وتجاوز الحدود التقليدية قليلا. جميع المنتجات ITAMA 100% مصنوعة في إيطاليا.





p. Product / Prodotto

012 **aluled**

062 **back**

076 **drop**

090 **easy**

100 **frame**

120 **io**

132 **noir**

144 **one**

152 **itashades**

170 **smoke**

180 **multi4**

188 **colors and fabrics**

# LET LIGHT LIVE ALULED





**ALULED** collection

[En] → **Solid light.** The essentiality of ALULED becomes a shape that transforms itself into a container for the light-source. The functional character of the object, that allows users to interact with it, was fundamentally important for the choice of the shapes: ergonomically sound and minimal. The detailing and the color range make the object contemporary and easy to use in any kind of room set.

**Solid light**

[It] → L'essenzialità in ALULED diventa forma traducendosi in contenitore della sorgente luminosa. Il carattere funzionale dell'oggetto, che consente all'utente di interagire con esso, è stato di fondamentale importanza per la scelta e lo studio della forma: ergonomica e minimale. I dettagli e la gamma cromatica contribuiscono a rendere l'oggetto contemporaneo e facilmente collocabile in ogni contesto.

**Massives Licht**

[De] → Die Wesentlichkeit in ALULED wird Form und Behälter der Lichtquelle. Die funktionelle Natur des Objekts ermöglicht dem Benutzer, damit zu interagieren. Dieses Merkmal war auch von grundlegender Bedeutung für die Auswahl und die Untersuchung der Form: ergonomisch und minimal. Details und Farbpalette machen es zeitgemäß und einfach in jedem Kontext zu platzieren.

**Осязаемый свет**

[Ru] → Модель ALULED предельно лаконична: источником и регулятором света служит весь корпус лампы, достаточно дотронуться до него рукой. Именно эта функциональная особенность и подсказала дизайнерам его эргономичную и минималистскую форму. Детали и цветовая гамма делают эту лампу современной и легко вписывающейся в любой интерьер.

**الضوء الصلب**

[Ar] → انها تحول نفسها الى وعاء لمصدر للضوء ALULED الهامة وضرورة ان الطابع الوظيفي للجسم، والتي تتنح للمستخدمين التفاعل معها، وأهمية أساسية لأختبار الأشكال : سليم هندسيا والحد الأدنى. تفصيل ولون طائفة تجعل الكائن المعاصرة وسهلة الاستخدام في اي نوع من الغرف.





**AP 200**  
wall lamp

**dimensions**  
W 20 x DPT 5 x H 2.5 cm

**color**  
white 9010



## **ALULED** → **bar zero**

[En] → ALULED BAR ZERO is a simple volume that seems projected from the wall. Due to its light, it gives a material perception to the surface. The lighting fixture is available in two versions: one fixed on the longer side with minimal protrusion. The other version is fixed on the short side, thus increasing the protrusion.

[It] → ALULED BAR ZERO si presenta come un semplice volume estruso dalla parete, che dona, grazie alla sua luce, matericità alla superficie. La lampada è disponibile in due versioni: una fissata alla superficie sul lato lungo con sporgenza minima, e un'altra che, al contrario, viene montata sul lato corto, aumentando così la sporgenza.

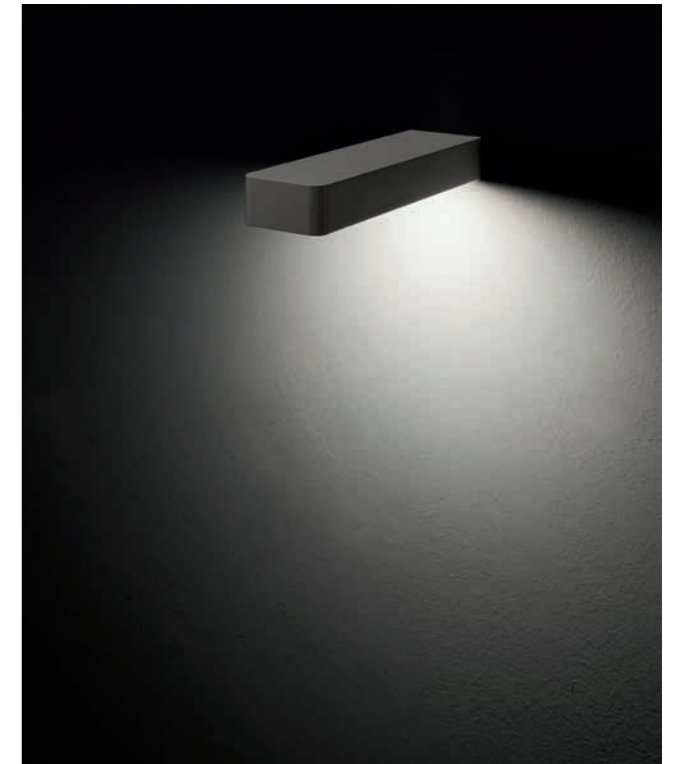

**AP 165**  
wall lamp

**dimensions**  
W 5 x DPT 16.5 x H 2.5 cm

**color**  
white 9010





## ALULED bar zero

AP 165  
wall lamp

dimensions  
W 5 x DPT 16.5 x H 5 cm

colors  
concrete + black 9005

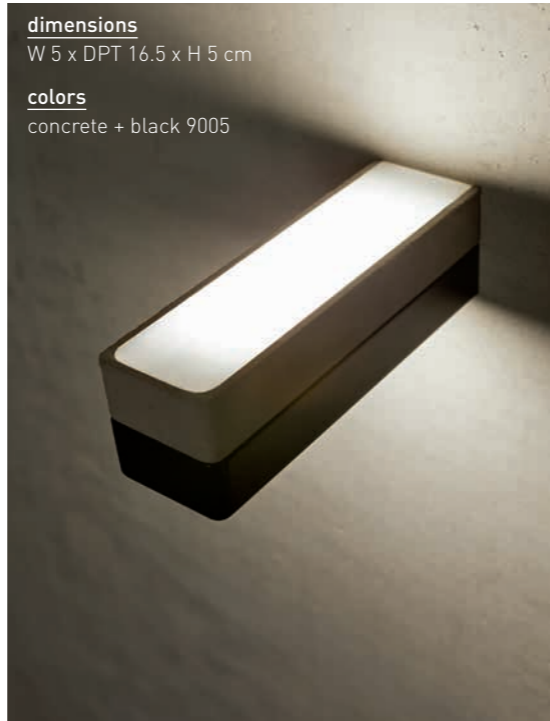

[En] → Joining two ALULED BAR ZERO allows to get a double light source lighting fixture. It is also possible to get various compositions combining various finishes.

[It] → L'accoppiamento di due elementi di ALULED BAR ZERO, permette di ottenere una lampada a doppia emissione. È possibile inoltre ottenere svariate soluzioni compositive accostando finiture diverse.

## ALULED bar zero

AP 165  
wall lamp

dimensions  
W 5 x DPT 16.5 x H 5 cm

colors  
dove 1019 + grey 7031







[En] → The cohesion between the powder-coated carved solid aluminium and the satin PMMA diffuser, creates an object with an elegant contemporary design. The careful study of the details, gives to the lighting fixtures a simple stylish effect.

[It] → L'unione tra l'alluminio ricavato dal pieno verniciato a polveri e il diffusore in PMMA satinato, crea un oggetto dal design contemporaneo e raffinato. Questa unione, che si caratterizza per l'attento studio dei dettagli, fa sì che la lampada si presenti pulita ed elegante.

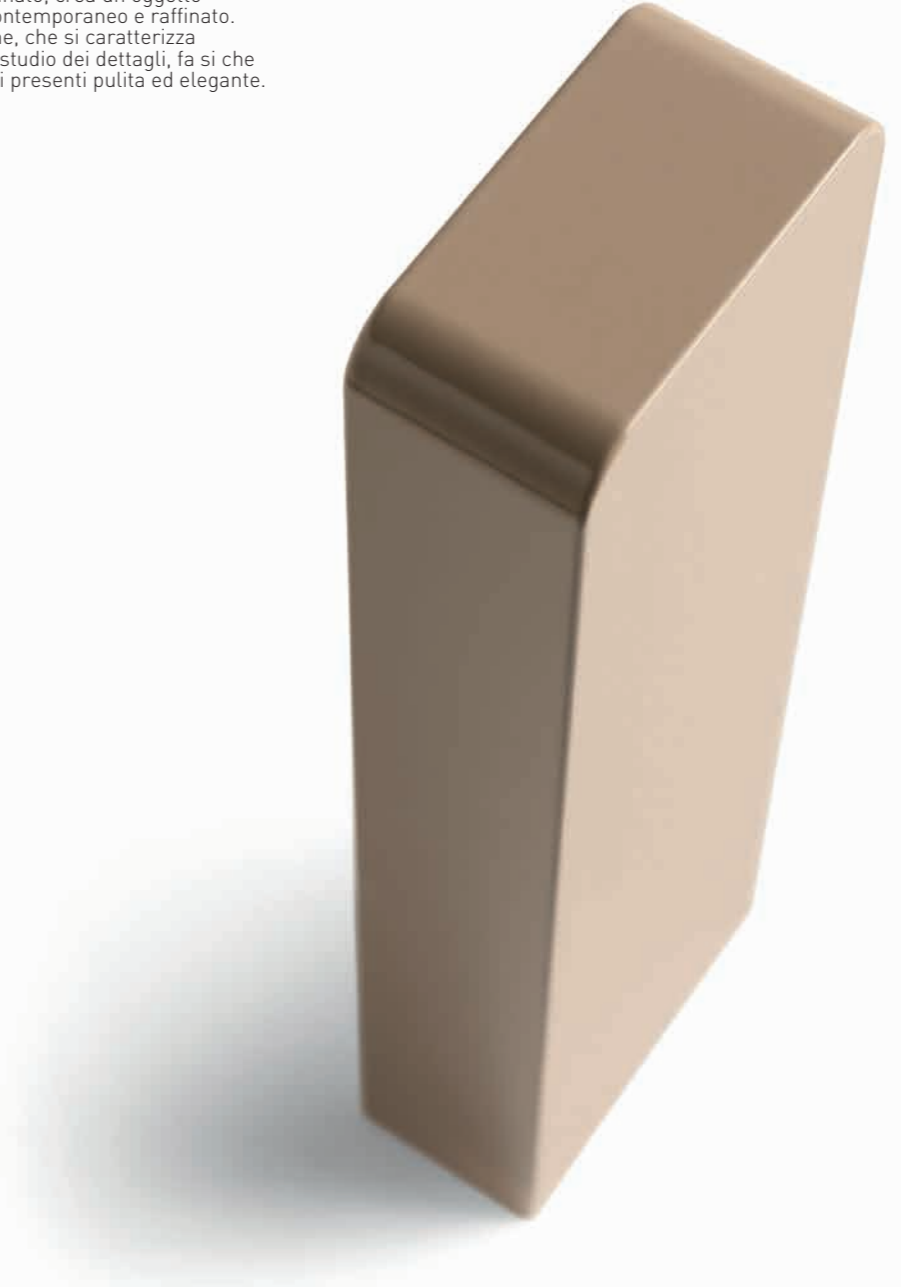

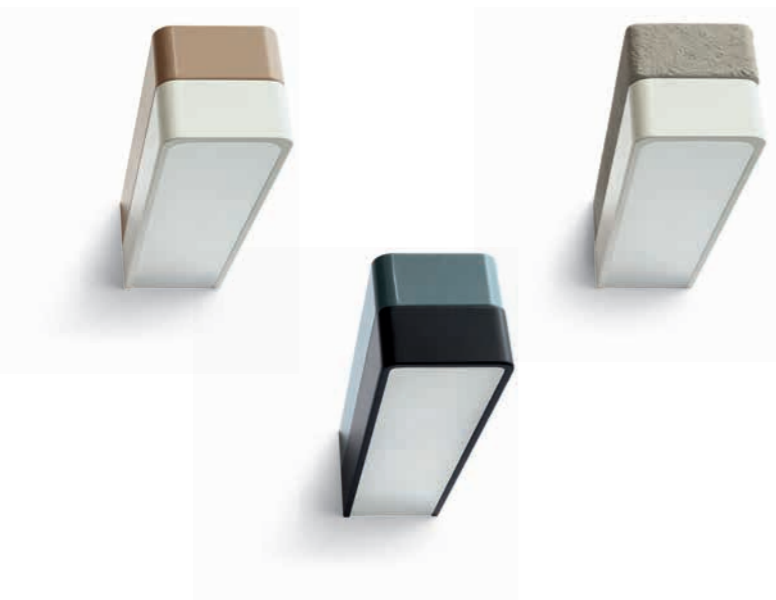

## ALULED bar zero collection

design L4B

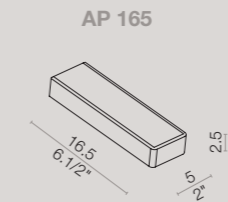
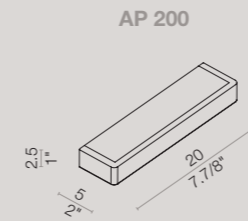

[En] → Lighting fixture in carved solid aluminium, powder-coated available in 4 colors and concrete finish. White PMMA diffuser. LED 220-240V. Not-adjustable version as wall lamp. Frame in powder-coated aluminium, available in 4 colors.

[It] → Corpo illuminante in alluminio ricavato dal pieno verniciato a polveri nei 4 colori disponibili e finitura cemento. Diffusore in PMMA bianco. Sorgente LED 220-240V. Versione fissa solo parete. Montatura in alluminio verniciato a polveri nei 4 colori disponibili.

## material

aluminium  
alluminio

## light source

LED 220-240V  
120V for  
NORTH AMERICADimmer not included  
Dimmer non incluso

## equipment

**BAR ZERO AP 200**  
13.5W LED 3000°K lm1450**BAR ZERO AP 165**  
13.5W LED 3000°K lm1450

Available 4000°K / Disponibile 4000°K

## symbols



## colors

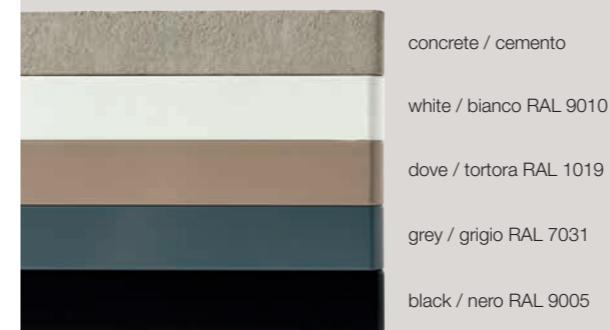

## photometric test BAR

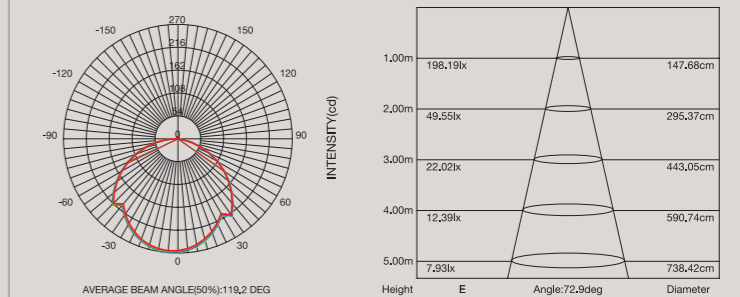





**PL 10 2L**  
ceiling lamp

**dimensions**  
L 38.5 x H max 12.5 cm

**colors**  
concrete + white 9010

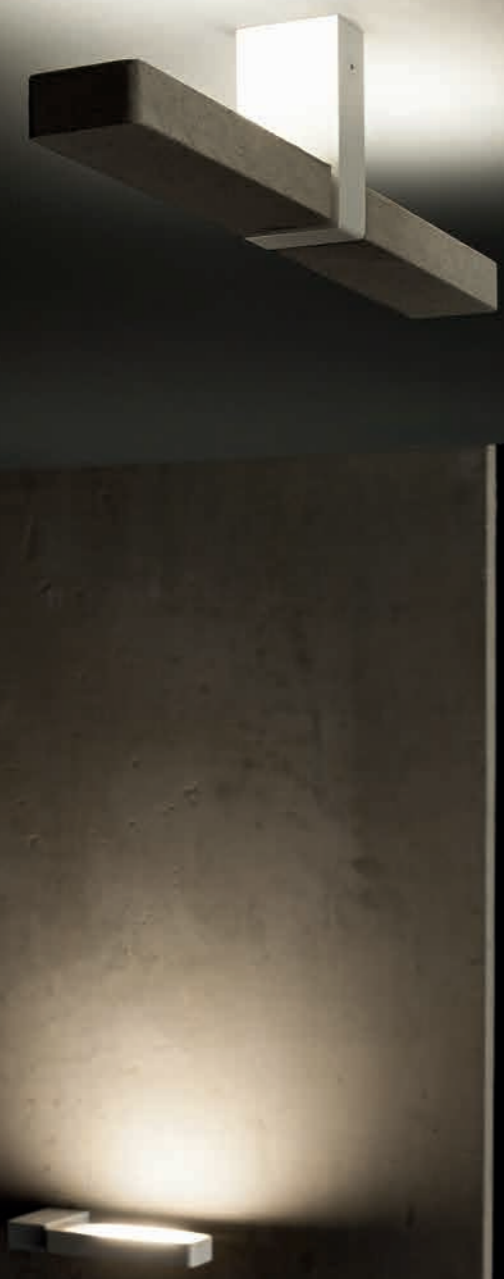

**ALULED**  
→ **bar**

[En] → Among the various available finishes, the concrete effect version is enhanced by a consistent texture, which contrasts with the minimalist design of the fixtures. This feature is emphasized in the version with junction, because by rotating its structure it is possible to touch and feel the roughness of concrete.

[It] → Tra le varie finiture disponibili, la versione effetto cemento è arricchita da una texture materica che contrasta con il design minimale della lampada. Questa caratteristica viene sottolineata nella versione snodabile in cui è possibile toccare e sentire la rugosità del cemento nel momento in cui il corpo illuminante viene ruotato.





[En] → The junction version of ALULED BAR has a 359 degrees rotation, directing the light at wish.

[It] → La versione snodabile di ALULED BAR permette la rotazione di 359 gradi del corpo illuminante, direzionando in questo modo la luce.



**ALULED bar**

**AP 1L**  
wall lamp

**dimensions**  
W 23 x DPT 12.5 cm

**colors**  
white 9010

## **ALULED bar**

**AP 1L**  
wall lamp

**dimensions**  
W 23 x DPT 12.5 cm

**color**  
black 9005



[En] → Both the junction and lighting element of ALULED BAR can be fitted in different ways: structure and single lighting fixture, or structure and double lighting fixture. It is possible to change the finishes of these parts, obtaining in this way several combinations.

[It] → Snodo ed elemento luminoso di ALULED BAR possono essere composti in diversi modi: montatura e corpo illuminante singolo oppure montatura e corpo illuminante doppio. Inoltre è possibile variare le finiture di queste parti ottenendo molteplici combinazioni.



**ALULED bar** collection

design L4B

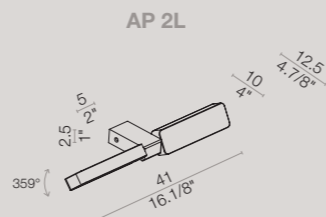
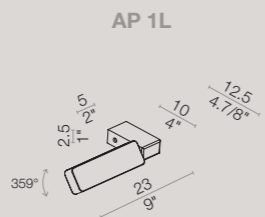
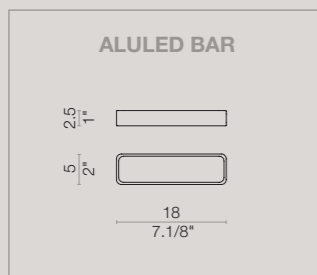

[En] → Lighting fixture in carved solid aluminium, powder-coated available in 4 colors and concrete finish. White PMMA diffuser. LED 220-240V. 359° adjustable version as wall/ceiling lamp. Frame in powder-coated aluminium, available in 4 colors. Chromed metal joint.

[It] → Corpo illuminante in alluminio ricavato dal pieno verniciato a polveri nei 4 colori disponibili e finitura cemento. Diffusore in PMMA bianco. Sorgente LED 220-240V. Versione orientabile 359° parete e plafoniera. Montatura in alluminio verniciato a polveri nei 4 colori disponibili. Snodo metallo cromato.

**PL 10 1L**

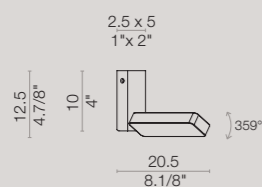

**PL 30 1L**

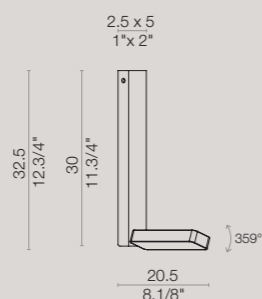

**PL 70 1L**



**PL 10 2L**

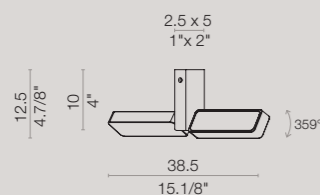

**PL 30 2L**

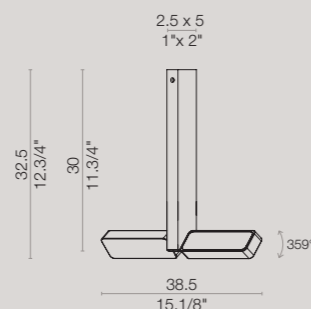

**PL 70 2L**



**material**

aluminium  
alluminio

**light source**

LED 220-240V

120V for  
NORTH AMERICA

Dimmer not included  
Dimmer non incluso

**equipment**

**AP 1L / PL 10 - 30 - 70 1L**  
13.5W LED 3000°K lm1450

**AP 2L / PL 10 - 30 - 70 2L**  
27W LED 3000°K lm2900

Available 4000°K /  
Disponibile 4000°K

**symbols**



**photometric test BAR**

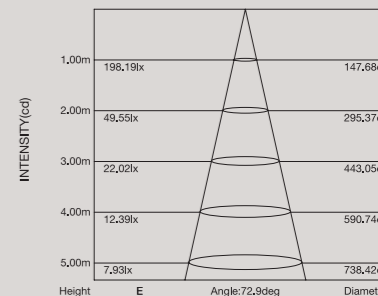
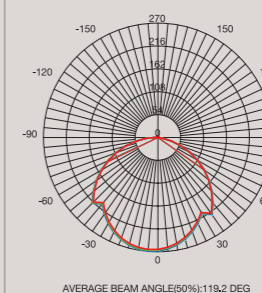

**colors**





**ALULED**  
→ **disc**

[En] → ALULED DISC is defined by the circular shape of the lighting fixture. The LED lighting source fits in a block of a carved solid aluminium which is a feature of this lamp and it is also at the same time a heat sink.

[It] → ALULED DISC, si caratterizza per la forma circolare del corpo illuminante. La sorgente luminosa LED, alloggiata in un volume di alluminio pieno che dà spessore, peso e importanza alla lampada e fa sì che quest'ultima, funga anche da dissipatore di calore.





## ALULED disc

**AP 1L**  
wall lamp

**dimensions**  
W 18 x DPT 15.5 cm

**colors**  
white 9010 + black 9005

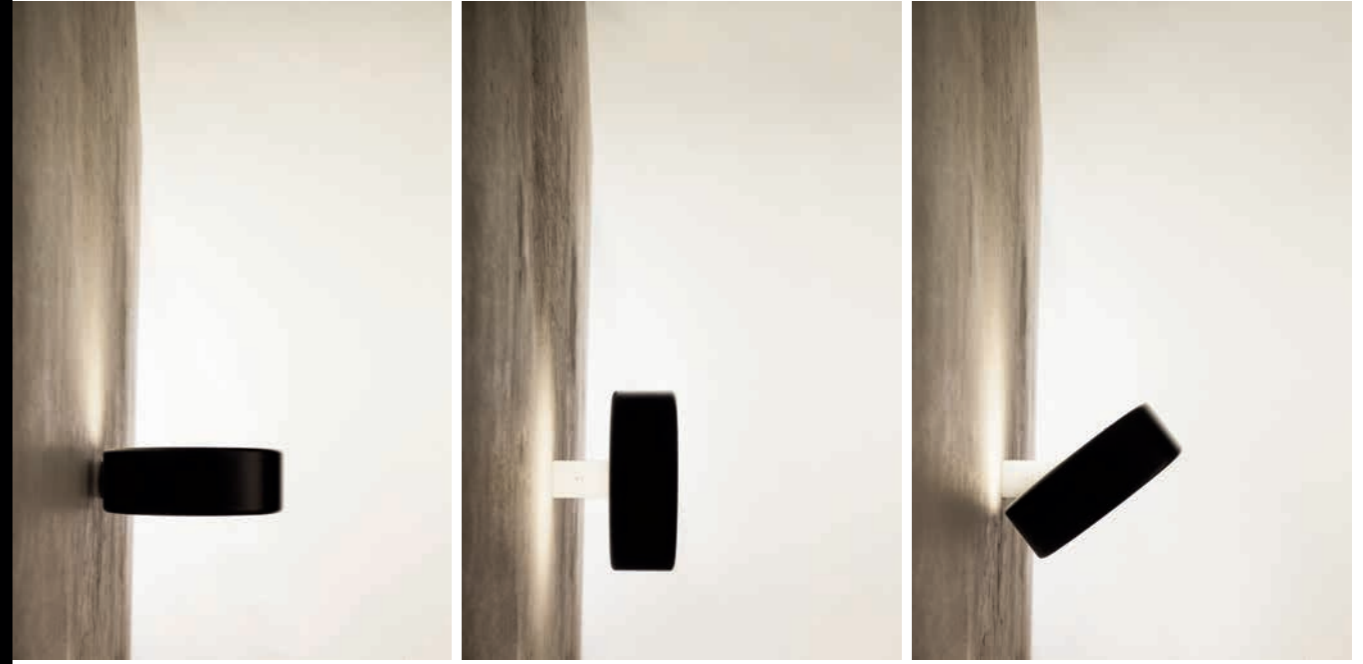

[En] → The aluminium support and chrome plated metal joint allow the lighting fixture 359° rotation. The length of the frame has been calculated in order to minimize the projection of this lighting fixture.

[It] → Il supporto in alluminio e lo snodo in metallo cromato, permettono al corpo illuminante di ruotare di 359 gradi. La lunghezza della montatura è stata calcolata in modo tale da ridurre al massimo la sporgenza della lampada.





**ALULED disc**

**PL 70 1L**  
ceiling lamp

**dimensions**  
L 15.5 x H max 75.5 cm

**colors**  
white 9010 + grey 7031

**ALULED disc**

**PL 30 1L**  
ceiling lamp

**dimensions**  
L 15.5 x H max 35.5 cm

**colors**  
white 9010 + grey 7031



**ALULED disc**

**PL 70 2L**  
ceiling lamp

**dimensions**  
L 28.5 x H max 75.5 cm

**colors**  
white 9010 + grey 7031

**ALULED disc** collection

design L4B

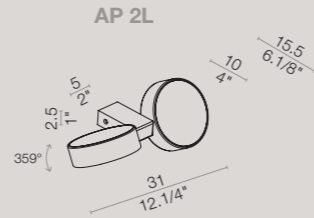
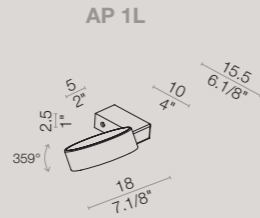
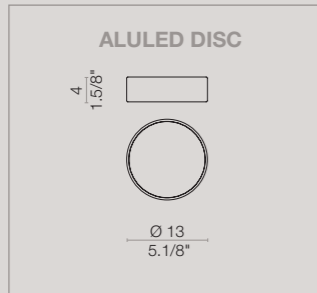

[En] → Lighting fixture in carved solid aluminium, powder-coated available in 4 colors and concrete finish. White PMMA diffuser. LED 220-240V. 359° adjustable version as wall/ceiling lamp. Frame in powder-coated aluminium, available in 4 colors. Chromed metal joint.

[It] → Corpo illuminante in alluminio ricavato dal pieno verniciato a polveri nei 4 colori disponibili e finitura cemento. Diffusore in PMMA bianco. Sorgente LED 220-240V. Versione orientabile 359° parete e plafoniera. Montatura in alluminio verniciato a polveri nei 4 colori disponibili. Snodo metallo cromato.

**PL 10 1L**

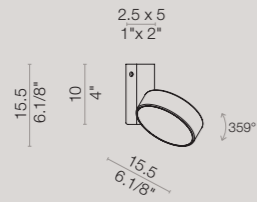

**PL 30 1L**

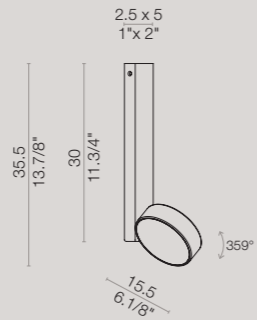

**PL 70 1L**



**PL 10 2L**

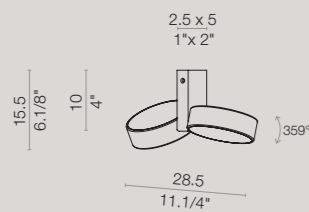

**PL 30 2L**

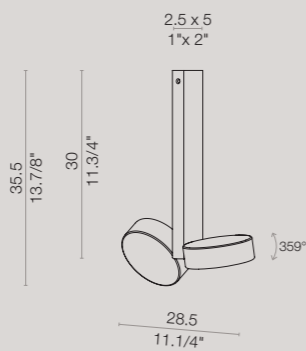

**PL 70 2L**



**material**  
aluminium  
alluminio

**light source**  
LED 220-240V  
120V for  
NORTH AMERICA  
Dimmer not included  
Dimmer non incluso

**equipment**  
**AP 1L / PL 10 - 30 - 70 1L**  
21W LED 3000°K lm1850  
**AP 2L / PL 10 - 30 - 70 2L**  
42W LED 3000°K lm3700

**symbols**  
F CE IP 20 DIM TRIAC eco

**photometric test DISC**

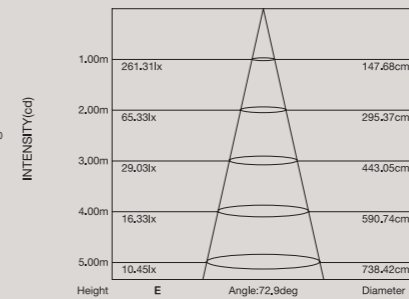
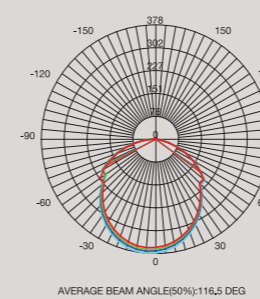

**colors**

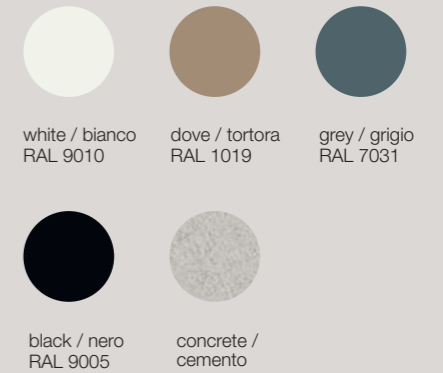





**AP 1L**

wall lamp

**dimensions**

W 17 x DPT 15 cm

**colors**

white 9010 + dove 1019



## **ALULED**

### → **square**

[En] → ALULED SQUARE is composed of a square element, a pure and regular shape softened by rounded edges. The lighting fixture is assembled in a single or double version with a powder coated aluminium support allowing installation of the fixture either on ceilings or on walls.

[It] → ALULED SQUARE, si compone di un elemento quadrato dalla forma pura e regolare ingentilita dall'arrotondamento degli spigoli. Il corpo illuminante è applicato, in versione singola o doppia a un supporto in alluminio verniciato a polveri consentendo l'utilizzo della lampada sia a soffitto che a parete.

**PL 30 1L**

ceiling lamp

**dimensions**

L 14.5 x H max 35 cm

**color**

dove 1019

**PL 70 2L**

ceiling lamp

**dimensions**

L 26.5 x H max 75 cm

**colors**

white 9010 + dove 1019

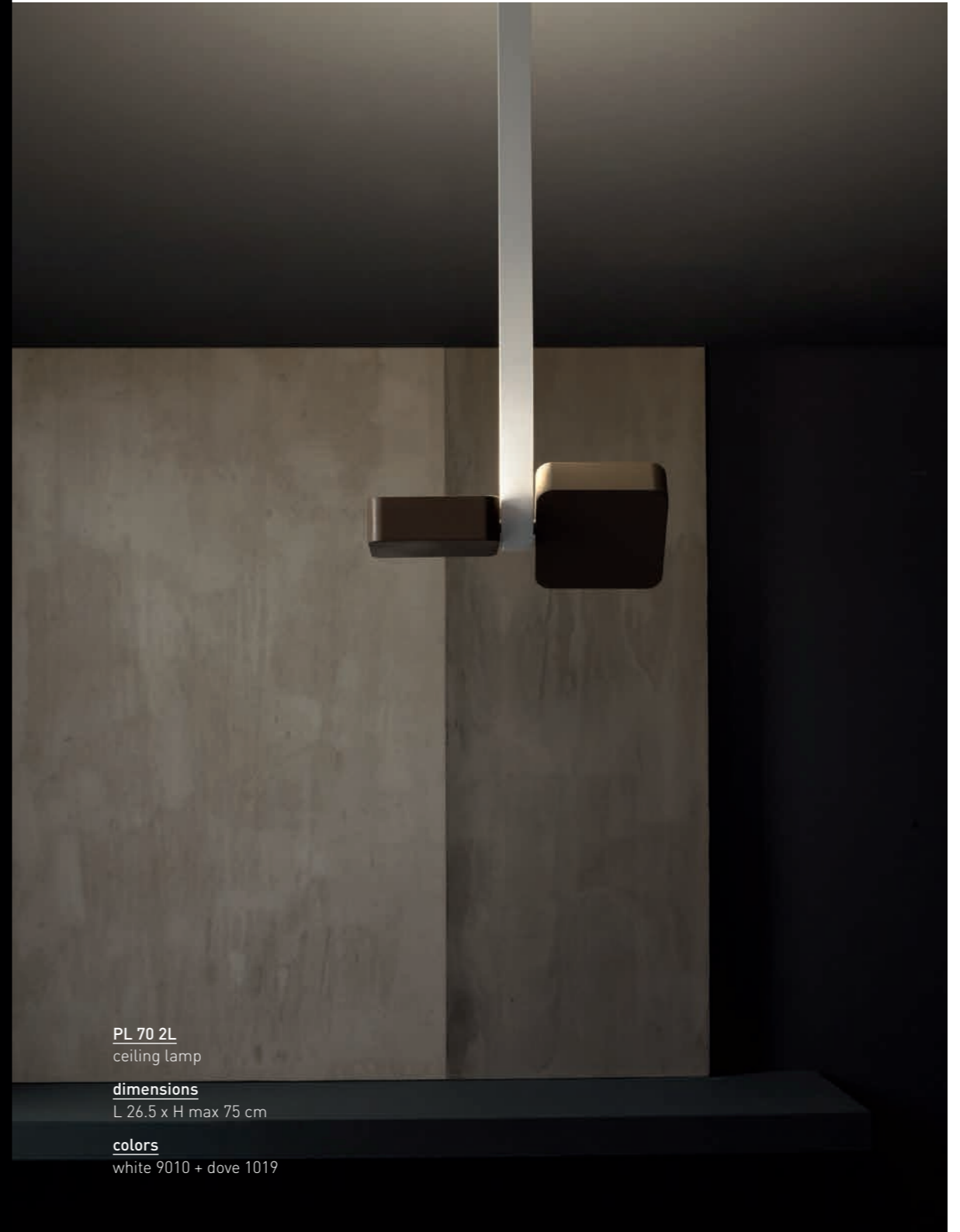



[En] → The chrome plated joints of ALULED SQUARE allow a 359° independent rotation of the lighting fixtures. The fixtures are assembled with a powder coated aluminium support available in three different lengths.

[It] → Gli snodi cromati di ALULED SQUARE, consentono la rotazione indipendente di 359 gradi dei corpi illuminanti. Questi ultimi, sono applicati ad un supporto in alluminio verniciato a polveri disponibile in tre lunghezze.

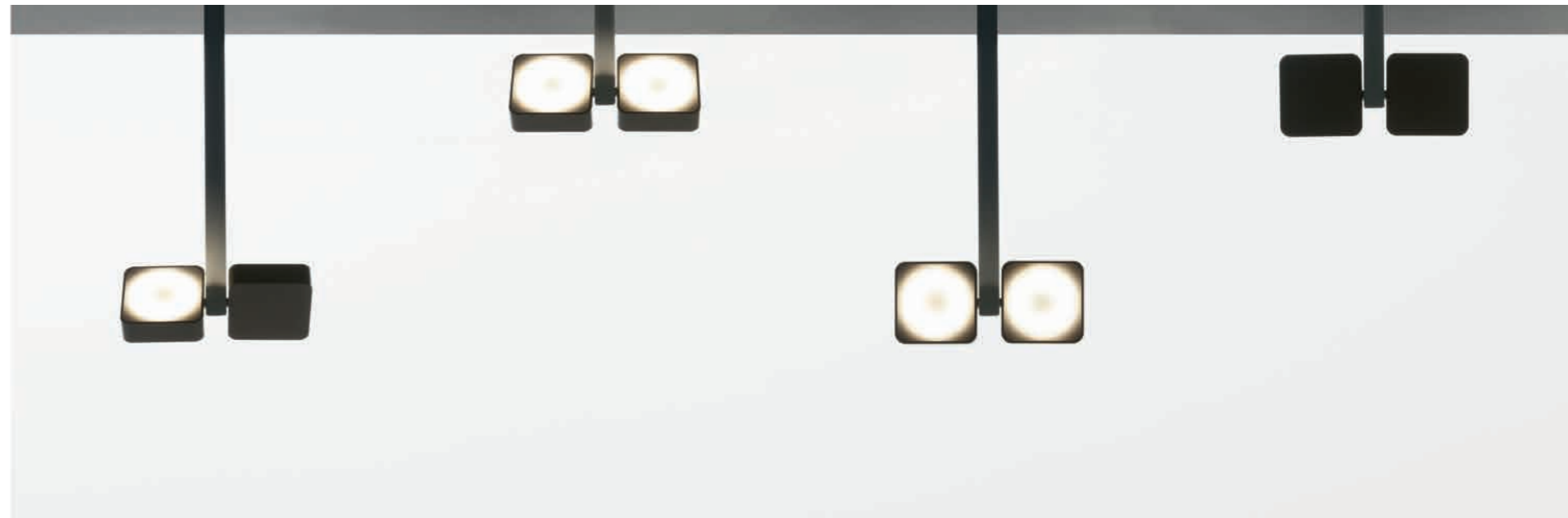

## **ALULED square**

**PL 30 2L**  
ceiling lamp

**dimensions**  
L 26.5 x H max 35 cm

**colors**  
grey 7031 + white 9010

[En] → The precision given by CNC machining, which is used to manufacture both the lighting fixture made from carved solid aluminium and the PMMA diffuser, allow the fixing system of the two parts with no visible mechanical elements.

[It] → La precisione data dalle lavorazioni a controllo numerico, con cui vengono prodotti sia il corpo illuminante ricavato da un pieno in alluminio, sia il diffusore in PMMA, permettono un fissaggio delle due parti, privo di elementi meccanici a vista.

## **ALULED square**

**PL 30 1L**  
ceiling lamp

**dimensions**  
L 14.5 x H max 35 cm

**colors**  
grey 7031 + white 9010





**ALULED square** collection

design L4B

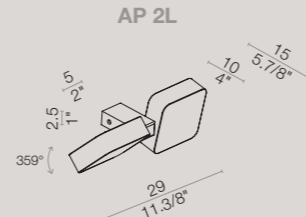
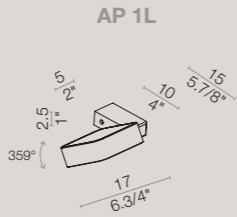
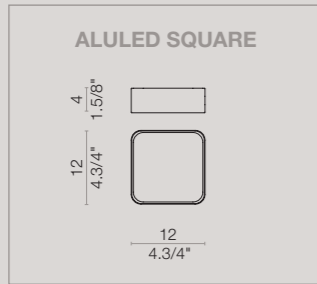

[En] → Lighting fixture in carved solid aluminium, powder-coated available in 4 colors and concrete finish. White PMMA diffuser. LED 220-240V. 359° adjustable version as wall/ceiling lamp. Frame in powder-coated aluminium, available in 4 colors. Chromed metal joint.

[It] → Corpo illuminante in alluminio ricavato dal pieno verniciato a polveri nei 4 colori disponibili e finitura cemento. Diffusore in PMMA bianco. Sorgente LED 220-240V. Versione orientabile 359° parete e plafoniera. Montatura in alluminio verniciato a polveri nei 4 colori disponibili. Snodo metallo cromato.

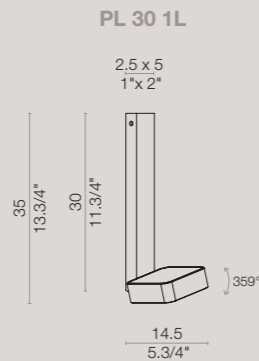
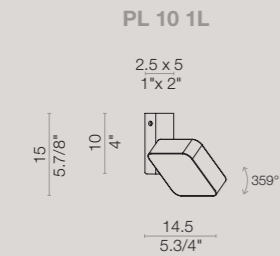

material

aluminium  
alluminio

light source

LED 220-240V  
120V for  
NORTH AMERICA  
Dimmer not included  
Dimmer non incluso

equipment

**AP 1L / PL 10 - 30 - 70 1L**  
21W LED 3000°K lm1850

**AP 2L / PL 10 - 30 - 70 2L**  
42W LED 3000°K lm3700

symbols

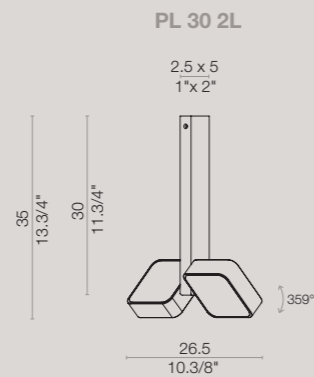
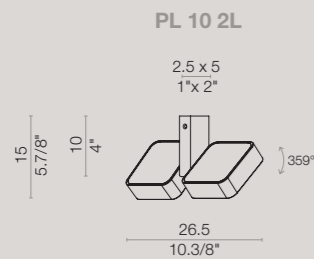
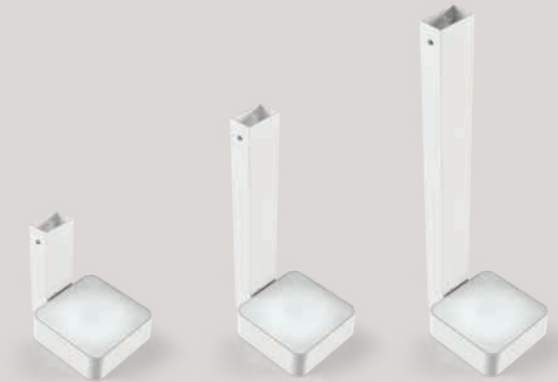

photometric test SQUARE

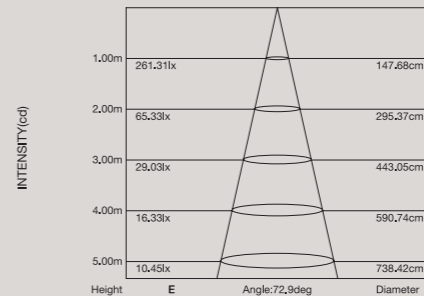
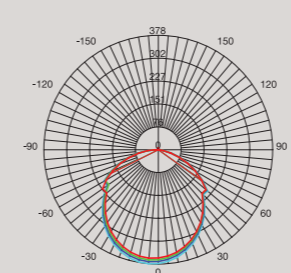

colors



**ALULED**  
→ **ring**

[En] → The large lighting fixture with the shape of a ring, made from a carved solid aluminium, fits perfectly around the LED lighting source, giving volume and shape to the light.

[It] → Il grande corpo luminoso a forma di anello, ricavato da un pieno in alluminio, avvolge perfettamente la sorgente luminosa a LED, dando volume e forma alla luce.





**ALULED ring**

**PL 30 2L**  
ceiling lamp

**dimensions**  
L 40.5 x H max 38 cm

**color**  
white 9010



**ALULED ring**

**PL 30 1L**  
ceiling lamp

**dimensions**  
L 19 x H max 38 cm

**color**  
white 9010







[En] → Due to its size, ALULED RING is only available in the ceiling version, with single or double lighting sources, both adjustable.

[It] → ALULED RING, date le sue dimensioni, è disponibile solo nella versione a soffitto, con singolo o doppio corpo illuminante ruotabile.

**ALULED ring** collection

design L4B

photometric test RING

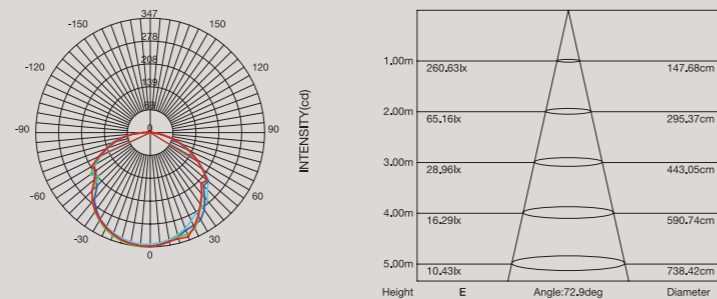

colors



[En] → Lighting fixture in carved solid aluminium, powder-coated available in 4 colors and concrete finish. White PMMA diffuser. LED 220-240V. 359° adjustable version as ceiling lamp. Frame in powder-coated aluminium, available in 4 colors. Chromed metal joint.

[It] → Corpo illuminante in alluminio ricavato dal pieno verniciato a polveri nei 4 colori disponibili e finitura cemento. Diffusore in PMMA bianco. Sorgente LED 220-240V. Versione orientabile 359° plafoniera. Montatura in alluminio verniciato a polveri nei 4 colori disponibili. Snodo metallo cromato.

material

aluminium  
alluminio

light source

LED 220-240V  
  
120V for  
NORTH AMERICA  
  
Dimmer not included  
Dimmer non incluso

equipment

**PL 10 - 30 - 70 1L**  
19W LED 3000°K lm1500  
  
**PL 10 - 30 - 70 2L**  
38W LED 3000°K lm3000

symbols



dimensions

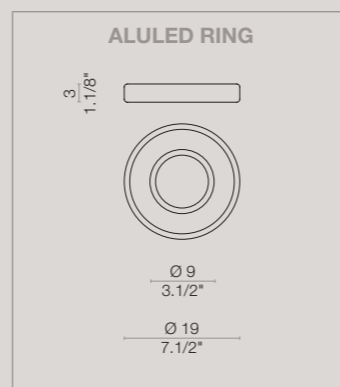

PL 30 1L

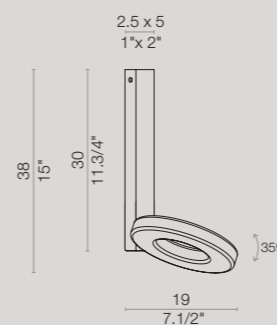

PL 70 1L

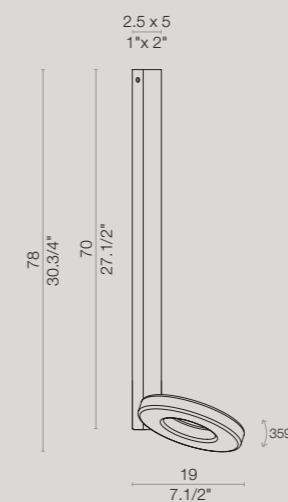

PL 30 2L

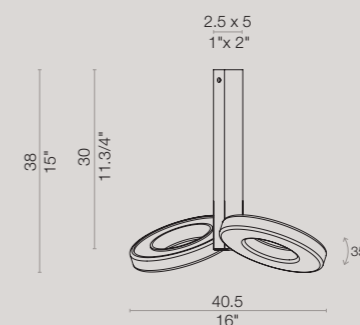

PL 70 2L

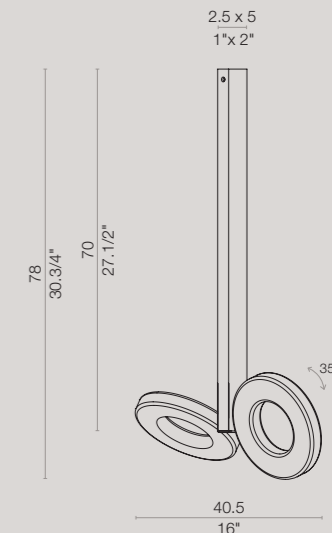

# BACK TO THE LIGHT







**BACK** collection

[En] → **The eclipse.** The simple gesture of overlapping two circular shapes, inserting a light source between them, gives this lamp the suggestive light of a lunar eclipse. The effect can be personalized and pointed for the wall light as one of the two discs is adjustable. The contrast of the reflecting element, always in white, and the darker disk is also underlined by the different color options for the second disc.

**L'eclisse**

[It] → Il semplice gesto di accostare due forme circolari, inserendo tra loro la sorgente luminosa, conferisce a questa lampada le suggestioni luminose di un'eclisse di luna. L'effetto può essere personalizzato e direzionato nella versione a parete, in cui uno snodo consente il movimento di uno dei due dischi. Il contrasto tra l'elemento riflettente, sempre bianco, e l'elemento in penombra è sottolineato dalle diverse colorazioni di quest'ultimo.

**Die Eklipse**

[De] → Der einfache Akt der Kombination von zwei Kreisformen, wo wir die Lichtquelle einfügen, gibt dieser Lampe das suggestive Licht einer Mondfinsternis. Der Effekt kann in die Wandleuchte personalisiert und gelenkt werden. In der Version ermöglicht ein Gelenk die Bewegung einer der zwei Kreisformen. Der Kontrast zwischen dem Reflexionselement, immer weiß, und das Element in der Dämmerung, wird durch unterschiedliche Farben dieses Elementes markiert.

**Затмение**

[Ru] → Единение двух дисков и встроенный между ними источник света, придает свечению этой лампы эффект затмения Луны. При креплении к стене этот эффект может быть персонализирован. По желанию два диска смещаются между собой. Контраст белого отражающего элемента подчеркивается элементом, находящимся в полутени, возможным в различных отделках.

**باك**

[Ar] → **BACK** هو عبارة عن إضاءة يتم تداخل اثنين من الأشكال الدائرية ، وإدراج مصدر الضوء بينهما، ويعطي هذا المصباح ضوء مستوحي من خسوف القمر. تأثير يمكن تخصيصه وتوجيه الضوء نحو الجدار باعتباره واحدا من اثنين من الأقراص الغير قابلة للتعديل.





## **BACK**

**AP 15 / AP 30**

wall lamp

### **dimensions**

W 18 x DPT min 10 - max 15 x H 21 cm

W 30 x DPT min 13 - max 26 x H 33 cm

### **color**

black 9005

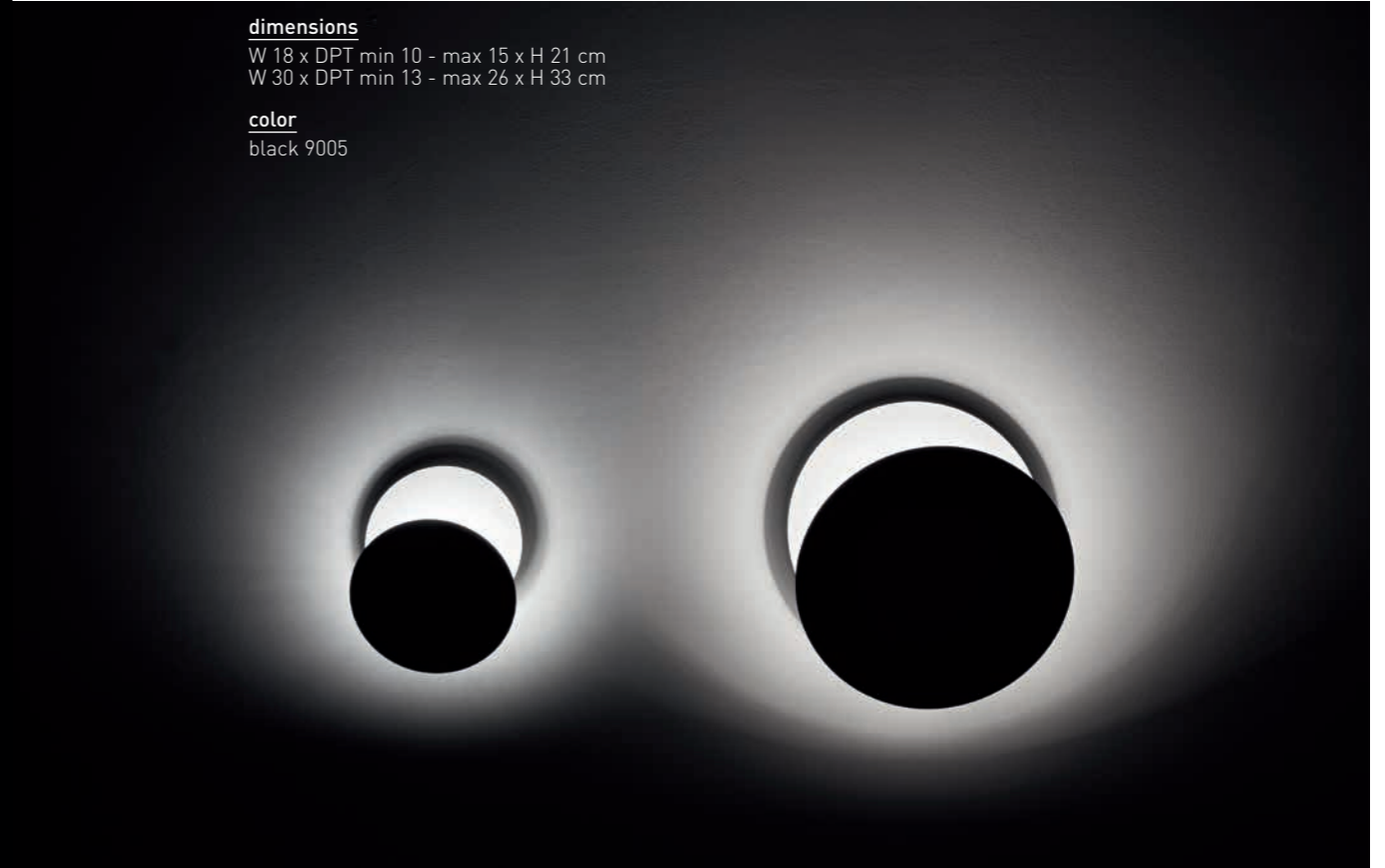

[En] → The light source placed inside the polished metal element, is shielded by a prismatic PMMA diffuser which ensures uniformity of light emission.

[It] → La sorgente luminosa collocata all'interno dell'elemento tornito in metallo, è schermata da un disco in PMMA prismatico che garantisce uniformità all'emissione della luce.





white 9010



dove 1019



black 9005

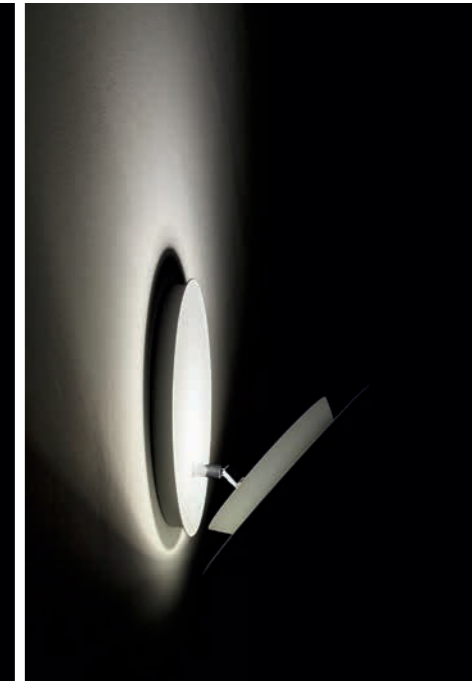
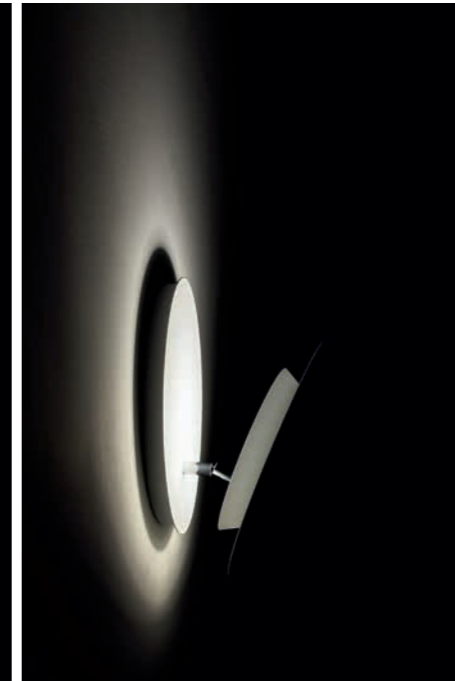

[En] → The joint allows a 60 degrees rotation from the diffuser, so that it is possible to change the direction of the light. The front reflector is available in three powder coated colors; the back reflector installed on the wall or on the ceiling comes only in white for greater reflectivity.

[It] → Lo snodo consente alla sorgente luminosa una rotazione di 60 gradi rispetto al diffusore: questo rende possibile variare la direzione dell'emissione luminosa. Il disco frontale è disponibile in tre colori verniciati a polveri, mentre quello montato a parete o soffitto è sempre di colore bianco per riflettere al meglio la luce.



[En] → The chrome plated metal cylinder is a structural part of the lamp, that connects the ceiling diffuser and frontal element. It also contains the wiring for the lighting source placed inside the polished plate.

[It] → Il cilindro in metallo cromato è un componente strutturale che collega il diffusore a soffitto all'elemento frontale, inoltre contiene il cavo di alimentazione della sorgente luminosa collocata all'interno del disco tornito.

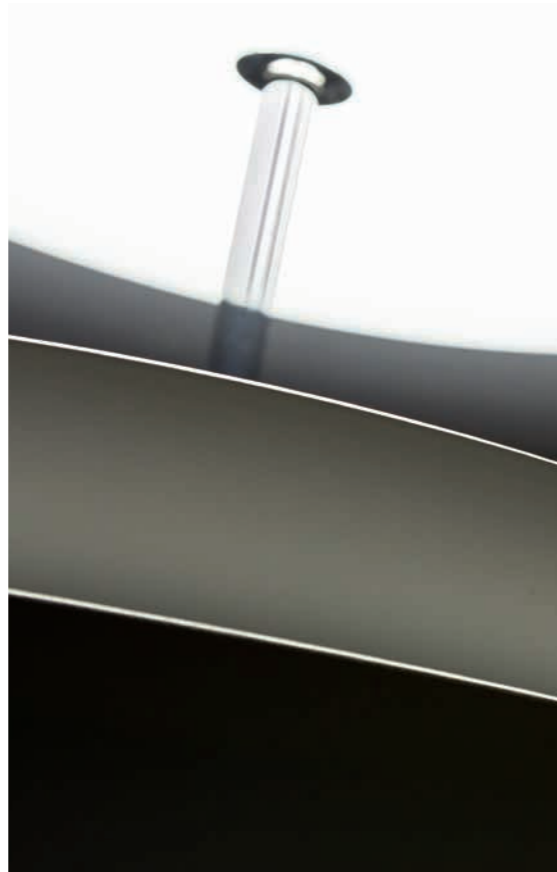

## BACK

PL  
ceiling lamp

dimensions  
Ø 50 x H 24.5 cm

colors  
dove 1019  
white 9010





**BACK** collection

design Massimo Tonetto



[En] → White powder-coated metal structure, RAL 9010. Powder-coated front reflector available in 3 colors. Only for the wall version it is adjustable by a chromed joint. Prismatic PMMA diffuser; LED 220-240V installed inside a polished element.

[It] → Struttura in metallo verniciato a polveri bianco RAL 9010. Disco frontale in metallo verniciato a polveri nei 3 colori disponibili regolabile con snodo cromato solo per versione a parete. Diffusore in PMMA prismatico e sorgente LED 220-240V posti all'interno dell'elemento tornito.

**AP 15**

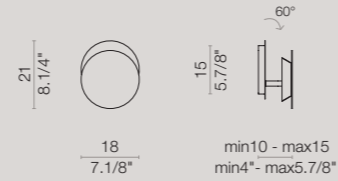

**AP 30**

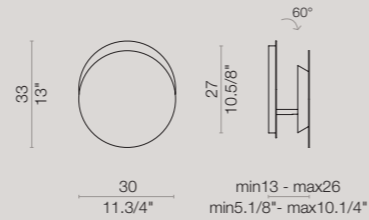

**PL**

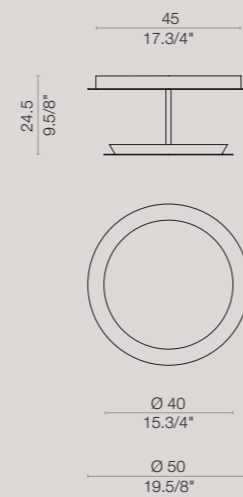

**material**

metal  
metallo

**light source**

LED 220-240V  
120V for  
NORTH AMERICA

Dimmer not included / Dimmer non incluso

**equipment**

**AP 15**  
12W LED 3000°K Im1200

**AP 30**  
21W LED 3000°K Im1850

**PL**  
38W LED 3000°K Im3000

**symbols**



**colors**



**photometric test**

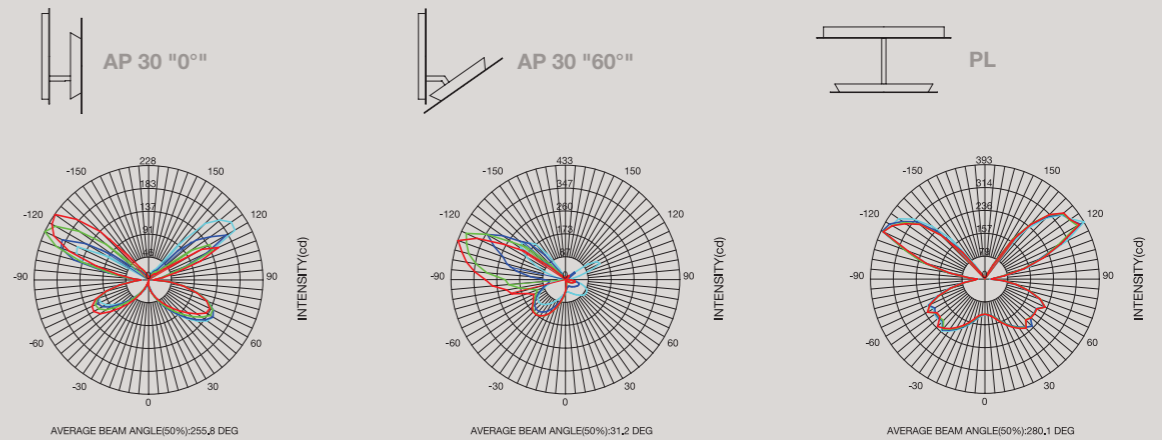



# LIGHT DROP BIG RIPPLE







## **DROP** collection

[En] → **A drop in the sea.** Like a stone thrown into water stirs waves and reverberation, light transforms and brings DROP to life. The glass diffuser, decorated by several layers of serigraphy, gives the product a decoration that can only be seen when the lamp is illuminated. The diffuser is also wrapped in a structural prismatic PMMA element that spreads the light in a uniform manner all around.



### **Una goccia nel mare**

[It] → Come il sasso lanciato in uno specchio d'acqua la anima di onde e riverberi, così la luce trasforma e dà vita a DROP. Il diffusore in vetro, decorato da diversi strati serigrafati, conferisce all'oggetto una decorazione luminosa visibile solamente accendendo la lampada. Quest'ultimo è avvolto da un elemento strutturale in PMMA prismatico che diffonde la luce in modo omogeneo nell'ambiente.

### **Ein Tropfen im Meer**

[De] → Ein Stein ins Wasser geworfen, lebt mit Wellen und konzentrischen Kreisen, so wie das Licht. Der Glasdiffusor, mit mehreren siebgedruckten Schichten dekoriert, gibt dem Objekt ein helles Erscheinen, das nur durch die Beleuchtung der Lampe sichtbar wird.

### **Морские капли**

[Ru] → Как камешек, брошенный на зеркальную поверхность воды, оставляет за собой круги, так и свет дает жизнь и трансформируется в модели DROP. Стеклоный рассеиватель с несколькими наложенными слоями трафаретной печати придает лампе при ее включении декоративный светящийся характер. Структурный элемент, сделанный в полиметилметакрилате, равномерно рассеивает свет в пространстве.

دروب  
قطرة في بحر

[Ar] → تحفة تتألق و ذلك نتيجة استخدام عنصر PMMA في تغليف الناشر مما يؤدي لانتشار الضوء بشكل موحد في كل مكان ، تجذب اهتمام الناظر عندما يضاء المصباح حيث تعطى زخرفة جميلة مثل حجر القفي في الماء فيثير التموجات والصدى.



**DROP**

**S0 45**  
suspension

**dimensions**  
Ø 48 x H 10 cm





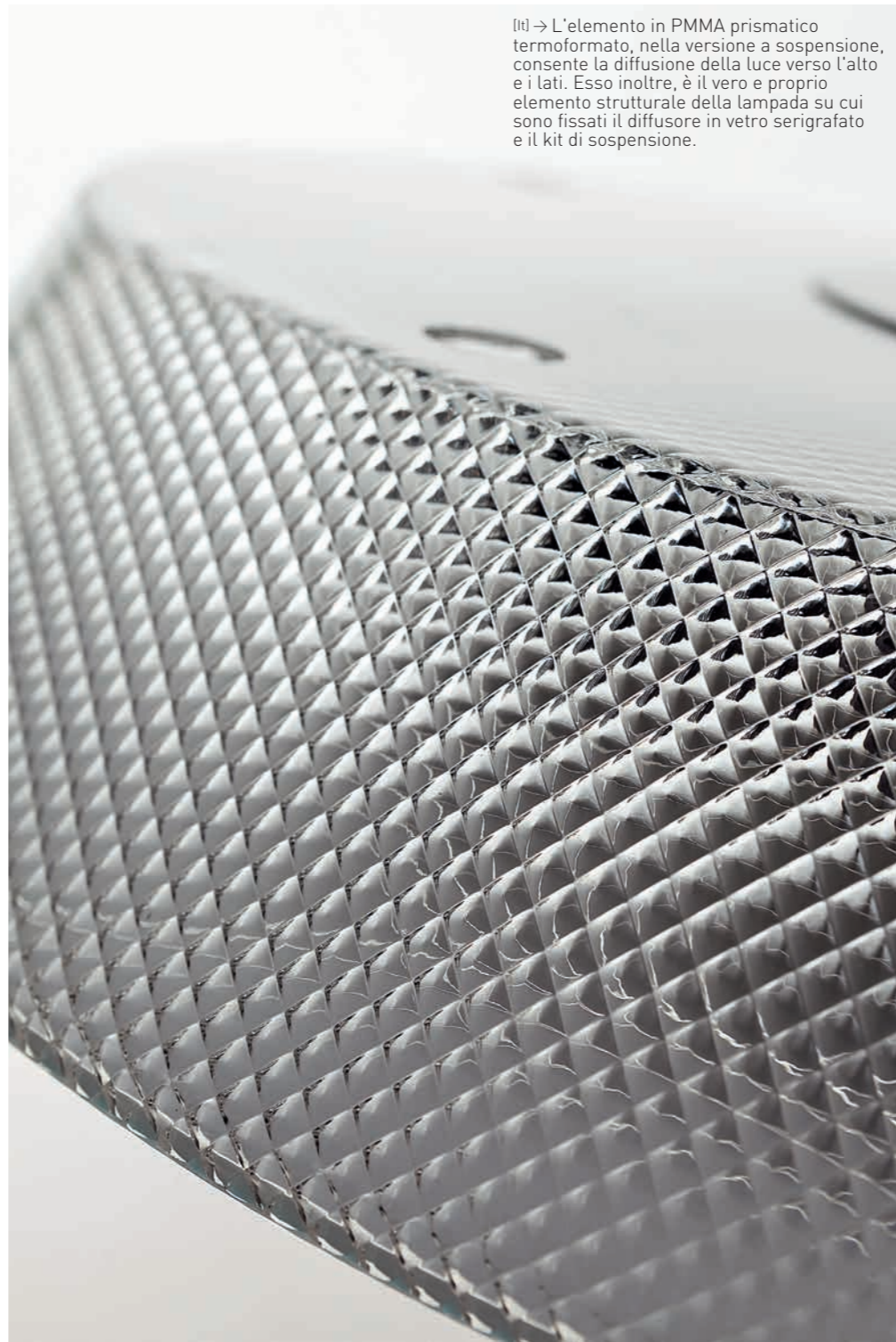

[En] → The prismatic thermoformed PMMA element in the hanging lamp allows the diffusion of indirect light to the top and to the sides. It is also the real structural element of the lighting fixture on which the silkscreened glass diffuser and the hanging kit are fixed.

[It] → L'elemento in PMMA prismatico termoformato, nella versione a sospensione, consente la diffusione della luce verso l'alto e i lati. Esso inoltre, è il vero e proprio elemento strutturale della lampada su cui sono fissati il diffusore in vetro serigrafato e il kit di sospensione.

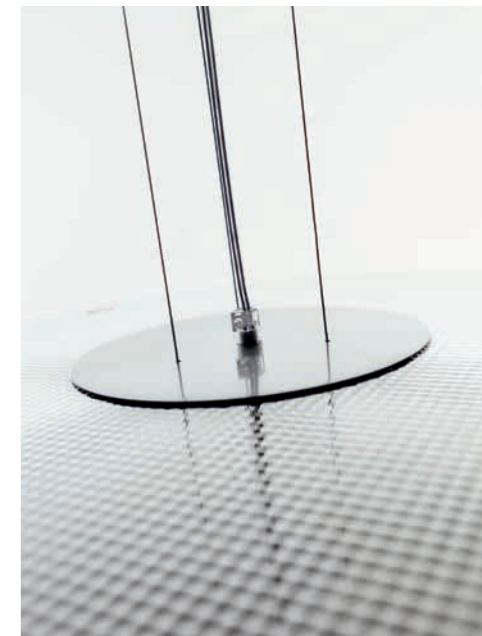



**DROP**

AP/PL 60  
wall or ceiling lamp

dimensions  
Ø 62.5 x DPT 10 cm

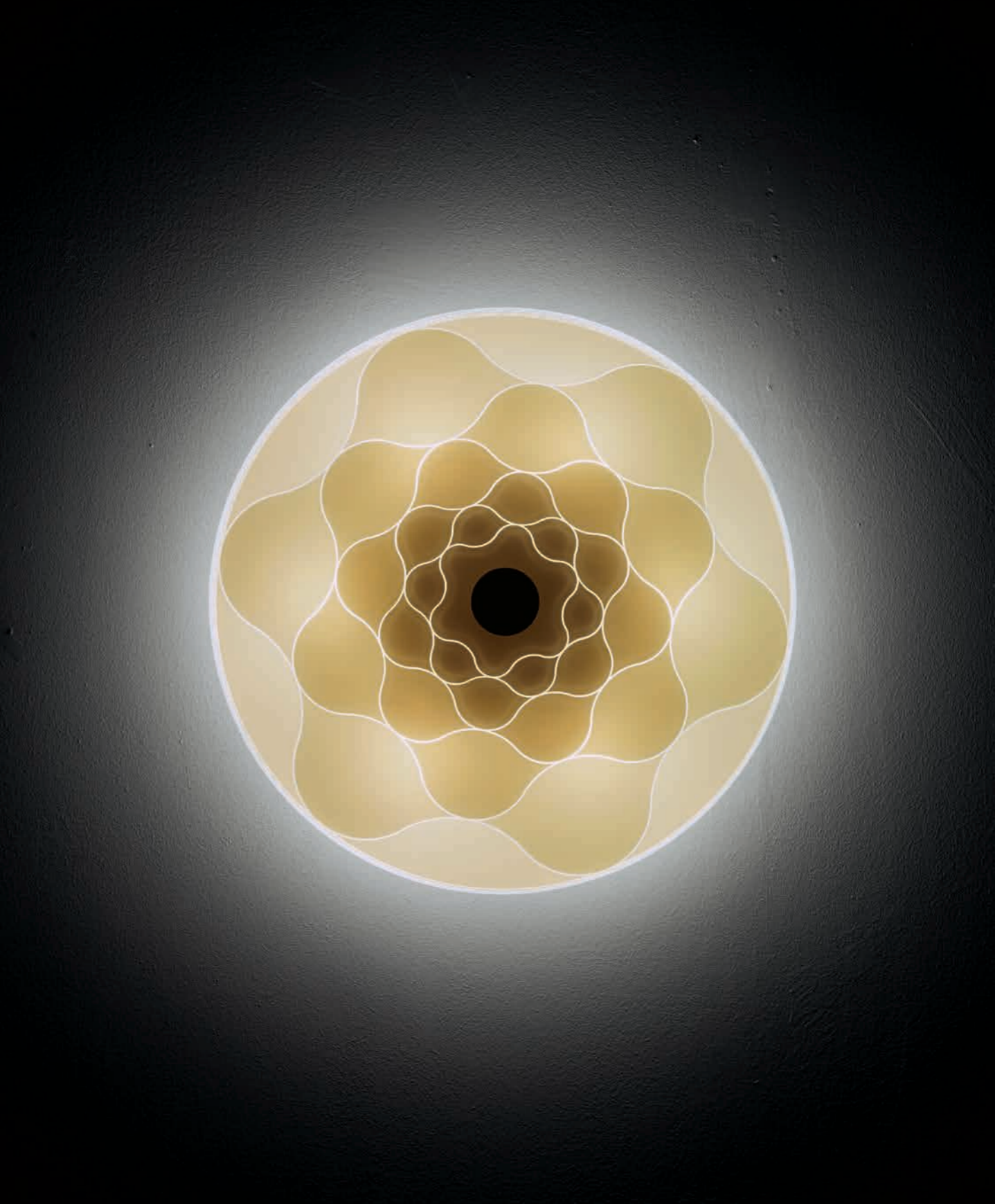



**DROP**

AP/PL 45  
wall or ceiling lamp

dimensions  
Ø 48 x DPT 10 cm







ON



OFF

[En] → When the lighting fixtures is off, the surface of the silkscreened glass diffuser looks like an even white surface, and you can see only the outlines of the floral decoration. When on, the surface is alive with different color shades, due to the number of silkscreen layers. Along the outline of the decoration, the light is clearer because there is less color; instead towards the center, where there is more color, the intensity of light decreases.

[It] → La superficie serigrafata del diffusore in vetro piano, quando la lampada è spenta, si presenta come una superficie omogenea bianca in cui si notano solo i contorni del decoro floreale. Con la luce, la superficie si anima di diverse tonalità determinate dalla quantità di strati di serigrafia. Lungo il perimetro, la luce è più chiara poichè minore è l'apporto di colore, mentre verso il centro, dove questo è maggiore, diminuisce l'intensità luminosa.

**DROP** collection

design Brian Rasmussen

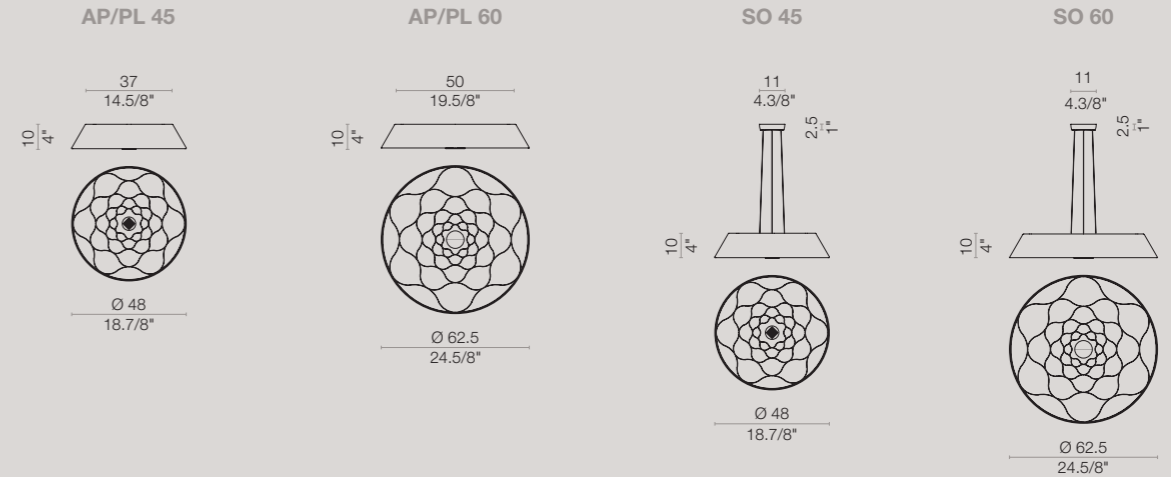

[En] → Flat panel glass front diffuser, with multi-layer silkscreened décor. Prismatic thermoformed PMMA side diffuser, detail in polished carved solid aluminium. LED 220-240V.

[It] → Diffusore frontale in vetro piano con decoro serigrafato multistrato. Diffusore laterale in PMMA prismatico termoformato, particolare in alluminio lucido ricavato dal pieno. Sorgente LED 220-240V.

**material**

Glass and PMMA  
Vetro e PMMA

**light source**

LED 220-240V

120V for  
NORTH AMERICA

Dimmer not included  
Dimmer non incluso

**equipment**

**AP/PL 45**  
38W LED 3000°K lm3000

**AP/PL 60**  
57W LED 3000°K lm4500

**SO 45**  
38W LED 3000°K lm3000

**SO 60**  
57W LED 3000°K lm4500

**symbols**

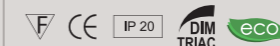
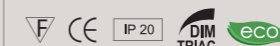
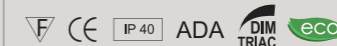
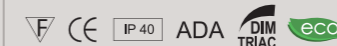

**photometric test DROP PL 60**

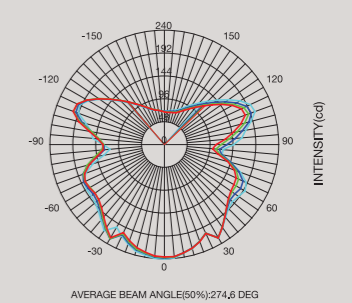



**EASY**  
LIKE  
AN IDEA



## EASY collection

[En] → **Suspended light.**

Simplicity and essential look are interpreted by the simple gesture of fitting a lamp in a lampholder, EASY is infact made of 3 simple elements: lamp, lampholder and metallic diffuser.

This last component rests on the light source reflecting downwards, greatly reducing the possibility of glare.

The lamp is suspended from the power feed which is dressed with a braided cover of the same color of the lampholder and diffuser, the shape of the diffuser is reflected in the ceiling rose.

### Luce sospesa

[It] → Semplicità ed essenzialità si traducono nel semplice gesto di avvitare una lampadina, EASY infatti si compone di soli tre elementi: lampadina, portalampada e diffusore in metallo. Quest'ultimo, grazie al suo foro centrale viene appoggiato sulla sorgente luminosa consentendo la riflessione della luce verso il basso impedendo l'abbagliamento frontale. La lampada è sorretta dal cavo di alimentazione rivestito in tessuto dello stesso colore del portalampada e del diffusore, la cui forma si ritrova in posizione specchiata nel rosone.

### Ausgesetztes Licht

[De] → Wesentlichkeit und Einfachheit in der einfachen Art eine Glühbirne zu schrauben. EASY besteht tatsächlich aus nur drei Elementen: Glühlampe, Fassung und Metaldiffusor. Letzteres ist aufgrund seiner zentralen Bohrung auf der Lichtquelle angelehnt. Der Metaldiffusor ermöglicht die Lichtreflexion nach unten und verhindert, durch das Licht geblendet zu werden.

Die Leuchte ist direkt an dem Stromkabel aufgehängt, das in der gleichen Farbe des Lampenhalters und des Diffusor ist. Die Form des Diffusor ist die gleiche wie die der Rosette, jedoch spiegelverkehrt.

### Парящий свет

[Ru] → Простота и сущность обыкновенного жеста вкручивания лампочки проявляется в модели EASY, ведь она как раз состоит всего из 3 элементов: лампочки, патрона и металлического рассеивателя. Благодаря центральному отверстию, рассеиватель крепится непосредственно на источник света, позволяя, таким образом, направлять свет вниз, предотвращая ослепление. Лампа держится на проводе, обтянутом тканью в цвет патрона и рассеивателя, форма которого повторяется в розоне.

### ( ايزي )

[Ar] → أساس البساطة من خلال تركيب أساس المصباح في حامل المصباح، مصنع من 3 عناصر بسيطة: مصباح، حامل مصباح والناشر المعدني. يقع هذا المكون الأخير على مصدر الضوء متما يعكس هبوط الضوء، للحد بشكل كبير من إمكانية الوهج. المصباح معلق بغطاء مضاف من نفس اللون من حامل مصباح والناشر المعدني







[En] → The conical shape of the diffuser, besides being the formal element which characterizes the lamp, also has a very important functional role: it avoids the light source glare and at the same time reflects and directs the light downward. The new technology allows the use of a light source that is able to combine the beauty and shape of the classic E 27 INC, with the LED light efficiency.

[It] → La forma conica del diffusore, oltre ad essere l'elemento formale che caratterizza la lampada, ha anche un ruolo funzionale molto importante: evitare l'abbagliamento dato dalla sorgente luminosa e allo stesso tempo riflettere ed indirizzare la luce verso il basso. La nuova tecnologia, permette di utilizzare una sorgente luminosa che sa unire alla bellezza e forma della classica E 27 INC, l'efficienza luminosa del LED.



**EASY**

**SO**  
suspension

**dimensions**  
Ø 12.5 x H 15 cm

**colors**  
blue 5005 / white 9010 / red 3004  
grey 7031 / green 6011 / black 9005 / dove 1019

**EASY** collection

design Massimo Tonetto

[En] → Powder-coated lamp holder cover, diffuser and ceiling rose, available in 7 colors. Chromed details. Electrical wire covered by fabric in the same color of metal components. E27 LED or halogen bulb.

[It] → Copri portalampada, diffusore e rosone in metallo verniciato a polveri nei 7 colori disponibili. Particolari in metallo finitura cromo. Cavo di alimentazione rivestito in tessuto colorato come le componenti metalliche. Sorgente luminosa LED oppure alogena con attacco E27.

## colors

black / nero  
RAL 9005white / bianco  
RAL 9010grey / grigio  
RAL 7031blue / blu  
RAL 5005red / rosso  
RAL 3004green / verde  
RAL 6011dove / tortora  
RAL 1019

## material

metal  
metallo

## light source

LED 220-240V or Halo  
120V for  
NORTH AMERICA

## equipment

**SO**1 x 6W LED E27 3000°K Im600  
light bulb included / lampadina inclusa  
or 1 x max 105W E27**SO 3L**3 x 6W LED E27 3000°K Im600  
light bulb included / lampadina inclusa  
or 3 x max 105W E27**SO 5L**5 x 6W LED E27 3000°K Im600  
light bulb included / lampadina inclusa  
or 5 x max 105W E27

## symbols

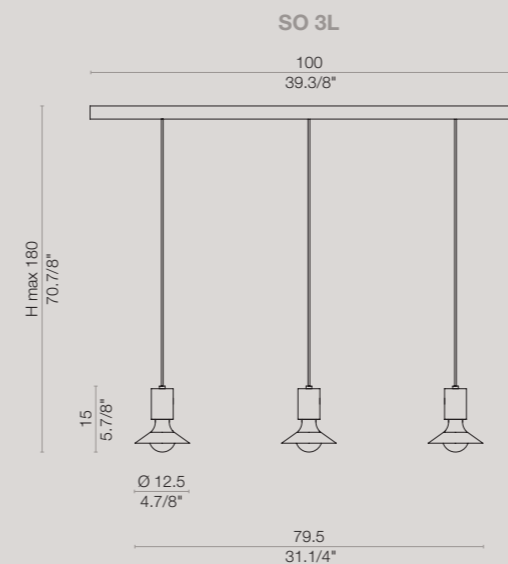
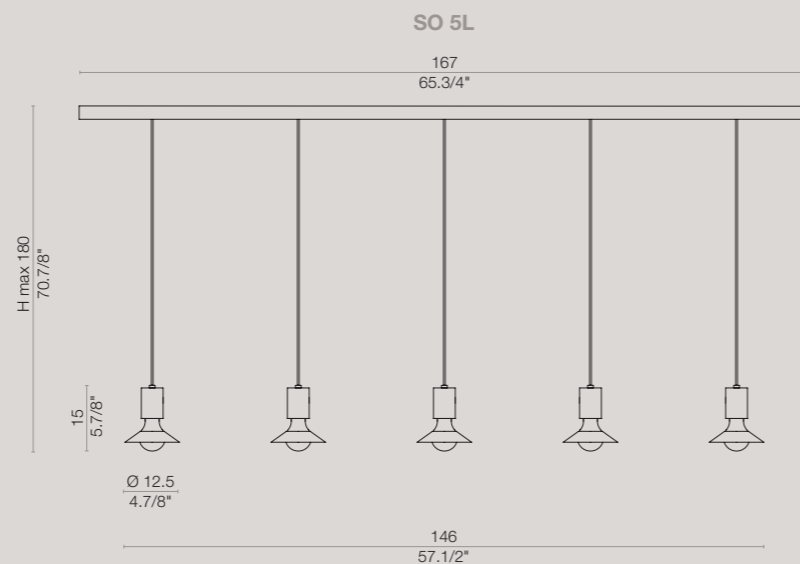





# FRAME AND GAME OF LIGHT



**FRAME** collection

[En] → **Signs and drawings made of light.** The linear LED light-source is the soul of this range: quality of light, minimal size and modularity. The extruded aluminium profile which contains the light-source is both a decorative and a structural element. The light is filtered by an opal PMMA profile that illuminates the underside of the fixture, giving the impression that the light beam is levitating. The different lengths of profile and the flexibility of the joining blocks make this range modular and easy to personalize.

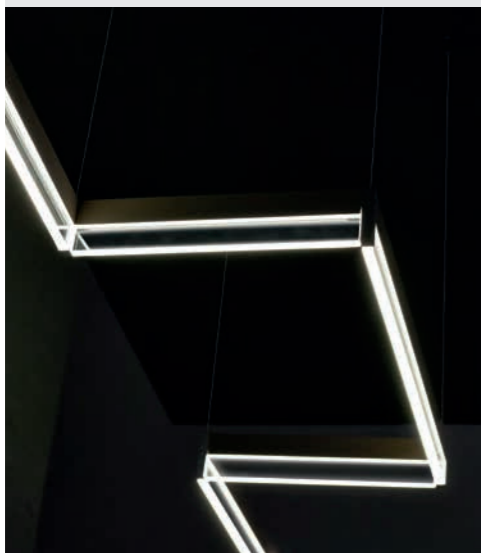
**Segni e di-segni di luce**

[It] → La sorgente luminosa lineare a LED, è l'anima della collezione: qualità della luce, ingombro minimo e modulare.

Il profilo estruso in alluminio, in cui alloggia il LED, diventa sia elemento decorativo che strutturale.

La luce che viene filtrata dal profilo in PMMA ne illumina la parte inferiore satinata, dando l'illusione che la fascia luminosa sia sospesa e galleggi nel vuoto. Le diverse dimensioni dei profili, e la flessibilità degli incastri, rendono l'oggetto modulare e personalizzabile.

**Lichtzeichen und Lichtzeichnungen**

[De] → Die lineare LED Lichtquelle ist die Seele der Kollektion: Lichtqualität, geringere und modulare Stellfläche.

Das Aluminium-Strangpressprofil, in dem sich das LED befindet, wirkt dekorativ und auch als Strukturelement. Das Licht, das durch das Profil der PMMA gefiltert wird, beleuchtet die matte Unterseite, sodass wir die Täuschung haben, dass das helle Band im Leeren hängt und schwebt. Die verschiedenen Größen der Profile und die Flexibilität der Gelenke bilden das Objekt als modular und anpassbar.

**Знаки и анти –знаки света**

[Ru] → Идея коллекции в линейном светодиодном источнике, его небольших размерах и модульности. Алюминиевый профиль, на котором находятся светодиоды, становится декоративно-структурным элементом. Свет, который поступает через профиль из полиметилметакрилата, освещает нижнюю матовую часть, и создается впечатление, что светящаяся полоса как бы парит в воздухе. Различные размеры профилей и возможность их совмещения делают эту модель универсальной для модулирования по персональным запросам.

علامات ورسومات مصنوعة من الضوء

[Ar] → الخطي، الضوء LED المصدر هو روح هذا النطاق: نوعية الضوء، والحد الأدنى حجم والنمطية. الألومنيوم المقذوف الذي يحتوي على مصدر للضوء قديكون على حد سواء كل من الديكور والعنصر الهيكلي. يتم تصفية الضوء من خلال أوبال "ب م م" الذي يضفي الجانب السفلي من الجهاز، وإعطاء الانطباع بأن تتعاين ضوء والرفع أطوال مختلفة. تجعل هذا النطاق سهلة للتخصيص.







**FRAME**

**COMPO 30x120**

suspension

**dimensions**

W 36 x L 126 x H 7 cm

**color**

dove 1019







**FRAME**

**SO 90L**

suspension

**dimensions**

L 96 x H 7 cm

**color**

white 9010





**FRAME**

**COMPO MIX 30x180**  
suspension

**dimensions**  
W 36 x L 195 x H 7 cm

**color**  
dove 1019



**FRAME****COMPO MIX 30x180**

suspension

**dimensions**

W 36 x L 195 x H 7 cm

**color**

dove 1019



[En] → The flexibility of FRAME is possible thanks to carved solid aluminium fixing elements, available as end caps, double joints for lines, and corners. To get the Compo Mix 30x180, as per photo, you need six corner elements and two end caps, which allow both to hang the composition and to fix the extruded aluminium profiles.

[It] → La flessibilità di FRAME è possibile grazie all'elemento di fissaggio in alluminio ricavato dal pieno, disponibile nelle versioni singolo, doppio o angolare. Per ottenere Compo Mix 30x180, in foto, sono necessari sei elementi angolari e due singoli, i quali permettono la sospensione della composizione e il fissaggio dei profili estrusi in alluminio.

[En] → FRAME is also available as a wall sconce in three different sizes. It can be mounted with the light source facing downwards or upwards and in both versions the distance from the wall is minimal.

[It] → FRAME è disponibile anche nella versione a parete in tre diverse dimensioni. Può essere montata con la sorgente luminosa rivolta verso il basso o verso l'alto e in entrambe le versioni la sporgenza rispetto alla superficie del muro è minima.

## **FRAME**

### **AP 30**

wall lamp

### **dimensions**

W 36 x H 7 x DPT 8 cm

### **color**

dove 1019



## **FRAME**

### **AP 60**

wall lamp

### **dimensions**

W 66 x H 7 x DPT 8 cm

### **color**

white 9010



FRAME AP 30

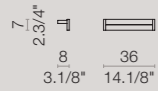

FRAME AP 60

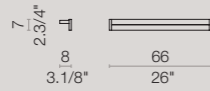

FRAME AP 90

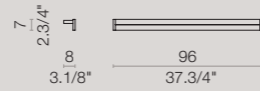

FRAME SO 30L

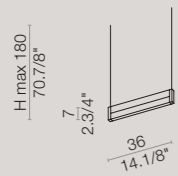

FRAME SO 60L

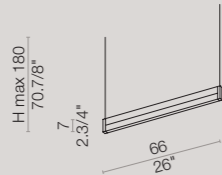

FRAME SO 90L

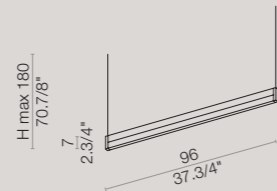

FRAME SO 120L

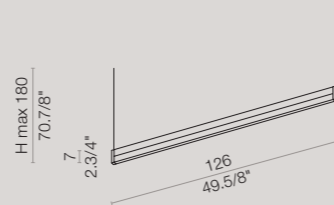

COMPO 30x30

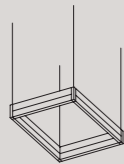

COMPO 30x60

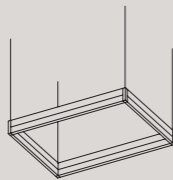

COMPO 30x90

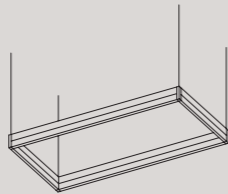

COMPO 30x120

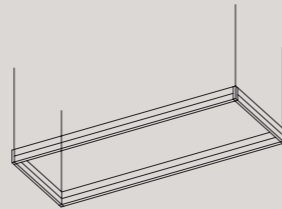

COMPO 60x60

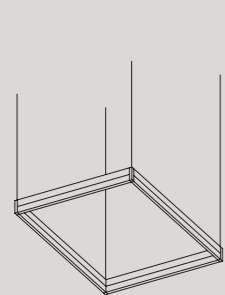

COMPO 90x90

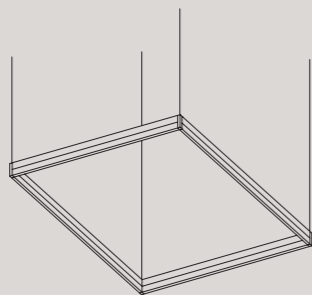

COMPO 120x120

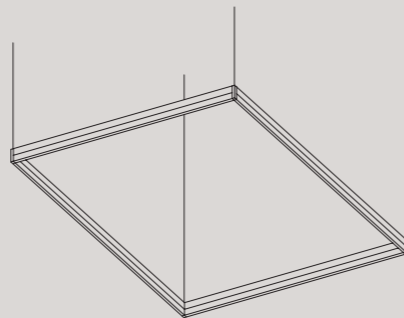

COMPO MIX 30x180

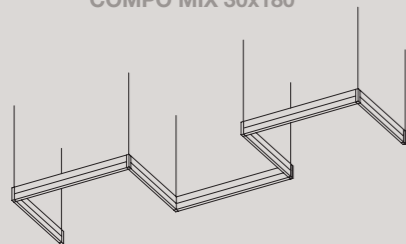

**FRAME** collection

design Brian Rasmussen

[En] → White powder-coated extruded aluminium profile, RAL 9010 or dove color RAL 1019. Transparent PMMA diffuser, satin finished on top and bottom edges. Fixing element in carved solid aluminium, row finish in single, double and corner version. Strip LED 20W/m 24V.

[It] → Profilo strutturale in alluminio estruso verniciato a polveri bianco RAL 9010 o tortora RAL 1019. Diffusore in PMMA trasparente con lato superiore e inferiore satinati. Elemento di fissaggio in alluminio ricavato dal pieno, finitura naturale nelle versioni singolo, doppio e angolare. Sorgente LED Strip 20W/m 24V.

**material**

aluminium and PMMA  
alluminio e PMMA

**light source**

LED 220-240V  
120V for  
NORTH AMERICA

**equipment**

- AP 30**  
6W LED 2700°K Im720
- AP 60**  
12W LED 2700°K Im1440
- AP 90**  
18W LED 2700°K Im2160

**symbols**

- ☑ CE IP 20 ADA
- ☑ CE IP 20 ADA
- ☑ CE IP 20 ADA

**colors**

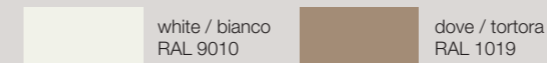

- SO 30L**  
6W LED 2700°K Im720
- SO 60L**  
12W LED 2700°K Im1440
- SO 90L**  
18W LED 2700°K Im2160
- SO 120L / COMPO 30x30**  
24W LED 2700°K Im2880

- ☑ CE IP 20
- ☑ CE IP 20
- ☑ CE IP 20
- ☑ CE IP 20

- COMPO 30x60**  
36W LED 2700°K Im4320
- COMPO 30x90 / COMPO 60x60**  
48W LED 2700°K Im5760

- ☑ CE IP 20
- ☑ CE IP 20

- COMPO 30x120**  
60W LED 2700°K Im7200

- ☑ CE IP 20

- COMPO 90x90**  
72W LED 2700°K Im8640

- ☑ CE IP 20

- COMPO 120x120**  
96W LED 2700°K Im11520

- ☑ CE IP 20

Available 4000°K / Disponibile 4000°K

Dimmerable LED driver available /  
Disponibile LED driver dimmerabile

**photometric test FRAME 30**

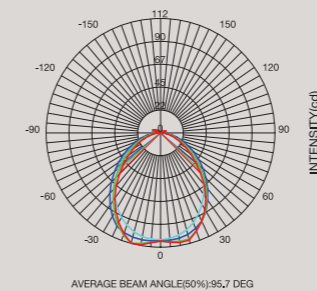

Height	AVR E	Angle:90,3deg	Diameter
1.00m	50,43lx		104,70lx 201,13cm
2.00m	12,61lx		26,18lx 402,26cm
3.00m	5,60lx		11,63lx 603,39cm
4.00m	3,15lx		6,54lx 804,52cm
5.00m	2,02lx		4,19lx 1005,65cm

# ME MYSELF AND IO



**IO** collection

[En] → **Cone of light.** The slow process of transformation of a tubular metal section to a slim and tapered cone, seems to attribute to the light-source the act of freezing the beam of light into a solid object. The accurate perfection of the surface, the specific weight and substance of the material, in contrast with the apparent fragility of the product, testify the value of the workmanship, all made in Italy. Last but not least, the varying color options, give the product an elegant and contemporary character.

**Cono di luce**

[It] → Il lento processo di trasformazione di un elemento tubolare in ferro in un cono dalla forma affusolata e snella, sembra voler attribuire alla luce l'atto di aver congelato e reso solido un fascio luminoso.

L'accurata levigatezza della superficie, il peso specifico e la sostanza del materiale, in contrasto con l'apparente esilità dell'oggetto, testimoniano il grande valore della lavorazione rigorosamente made in Italy. Infine, la svariata gamma di colorazioni, in cui è disponibile la lampada, ne conferisce un carattere elegante e contemporaneo.

**Lichtkegel**

[De] → Der langsame Prozess der Transformation von einem rohrförmigen Eisenelement in einen konischen und spindelförmigen Kegel, scheint für das Licht selbst den Grund für das Einfrieren und Erstarren des Lichtstrahls zu geben. Die genaue Oberflächenglätte, das spezifische Gewicht und die Substanz des Materials, im Gegensatz zu der scheinbaren Dünne des Objekts, ist Ausdruck des großen Wertes der genauen Verarbeitung "Made in Italy". Schließlich ergibt die abwechslungsreiche Auswahl an Farben ein elegantes und zeitgemäßes Design.

**Световой конус**

[Ru] → Кажется, что постепенный процесс превращения металлической трубы в стройный конус, являет свету акт трансформации светового луча в осязаемый источник света. Идеально гладкая поверхность, вес и специальный материал играют на контрасте видимой легкости лампы, что свидетельствует о высоком качестве проектирования светильника, полностью произведенного в Италии. Возможность изготовления лампы в большом количестве разнообразнейших цветов придает ей элегантный и современный вид.

**إيو**

[Ar] → المنتج المصنوع في إيطاليا يمثل قطعة فنية تظهر فيها الدقة كما البساطة باستخدام أنبوب استائليس ستيل و ينتهي بشكل مخروطي بقمة الإتقان ، كما و تأتي القطعة بعدة ألوان مما يعطي المنتج طابع عصري و أنيق.









**IO**

S0  
suspension

dimensions  
Ø 7 x H 77.5 cm

color  
chrome





white 9010

dove 1019

grey 7031

black 9005

chrome

concrete

[En] → The conical shape of the lighting fixture is enhanced by a variety of colors and finishes: four powder coated colors, plus chromed and concrete finish. For all colors a special metal chromed detail is applied between the fixture and the electrical wire that supports it.

[It] → La forma conica della lampada viene valorizzata dai vari colori e finiture: quattro tonalità verniciate a polveri, la versione cromata e quella trattata a effetto cemento. A tutte le varianti è applicato un particolare tornito in metallo cromato posto tra il corpo illuminante e il cavo di alimentazione che lo sostiene.





IO collection

design Massimo Tonetto

SO



MINI SO

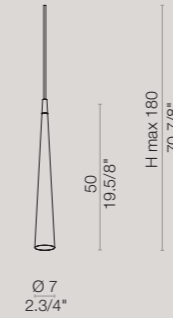

[En] → Powder-coated metal conical tube available in 4 colors, chrome plated and concrete finish. Chrome plated metal cord grip. GU10 LED for direct light.

[It] → Tubo in metallo conificato verniciato a polveri nei 4 colori, cromato e finitura cemento. Particolare blocca cavo in metallo tornito ricavato dal pieno finitura cromo. Sorgente LED attacco GU10 con emissione di luce diretta.

SO 5L

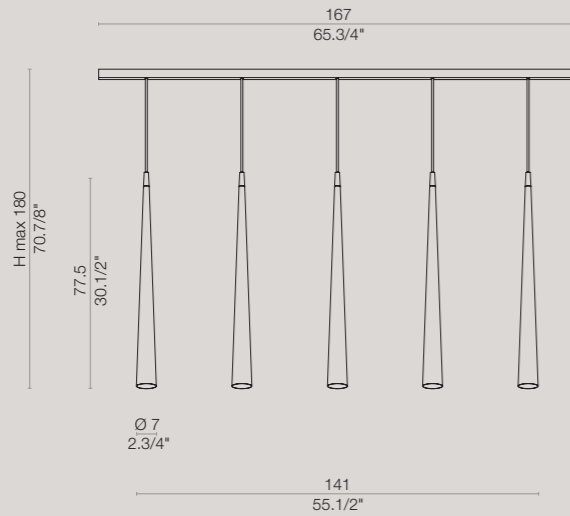

SO 3L

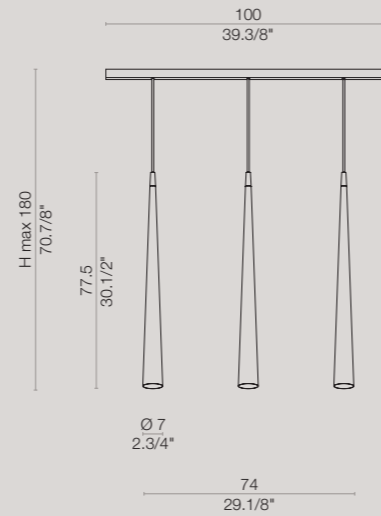

MINI SO 5L

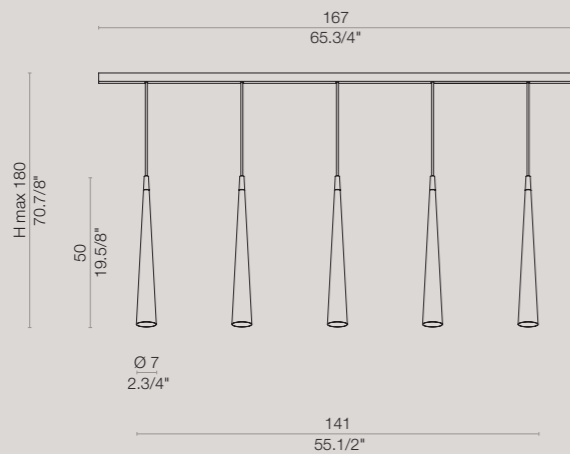

MINI SO 3L

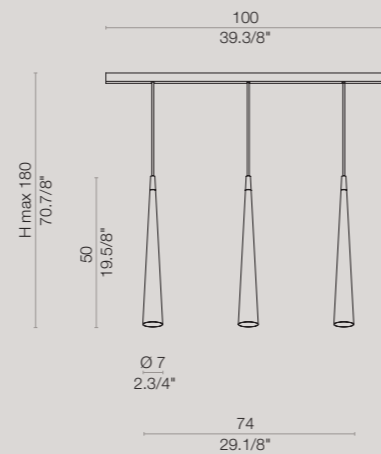

material

metal  
metallo

light source

LED 220-240V or Halo  
  
120V for  
NORTH AMERICA

equipment

**SO / SO MINI**  
1 x 7W LED GU10 3000°K lm450  
or 1 x max 40W GU10

**SO 3L / MINI SO 3L**  
3 x 7W LED GU10 3000°K lm450  
or 3 x max 40W GU10

**SO 5L / MINI SO 5L**  
5 x 7W LED GU10 3000°K lm450  
or 5 x max 40W GU10

symbols



colors



photometric test SO

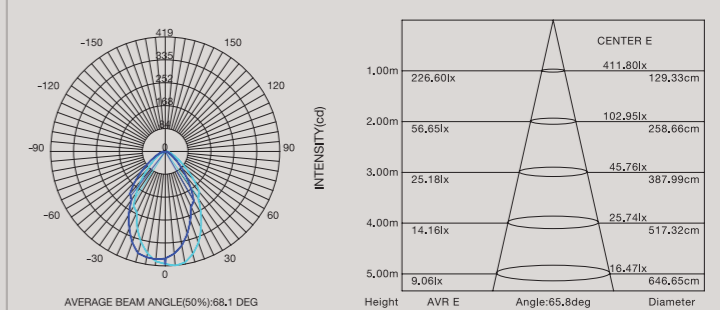

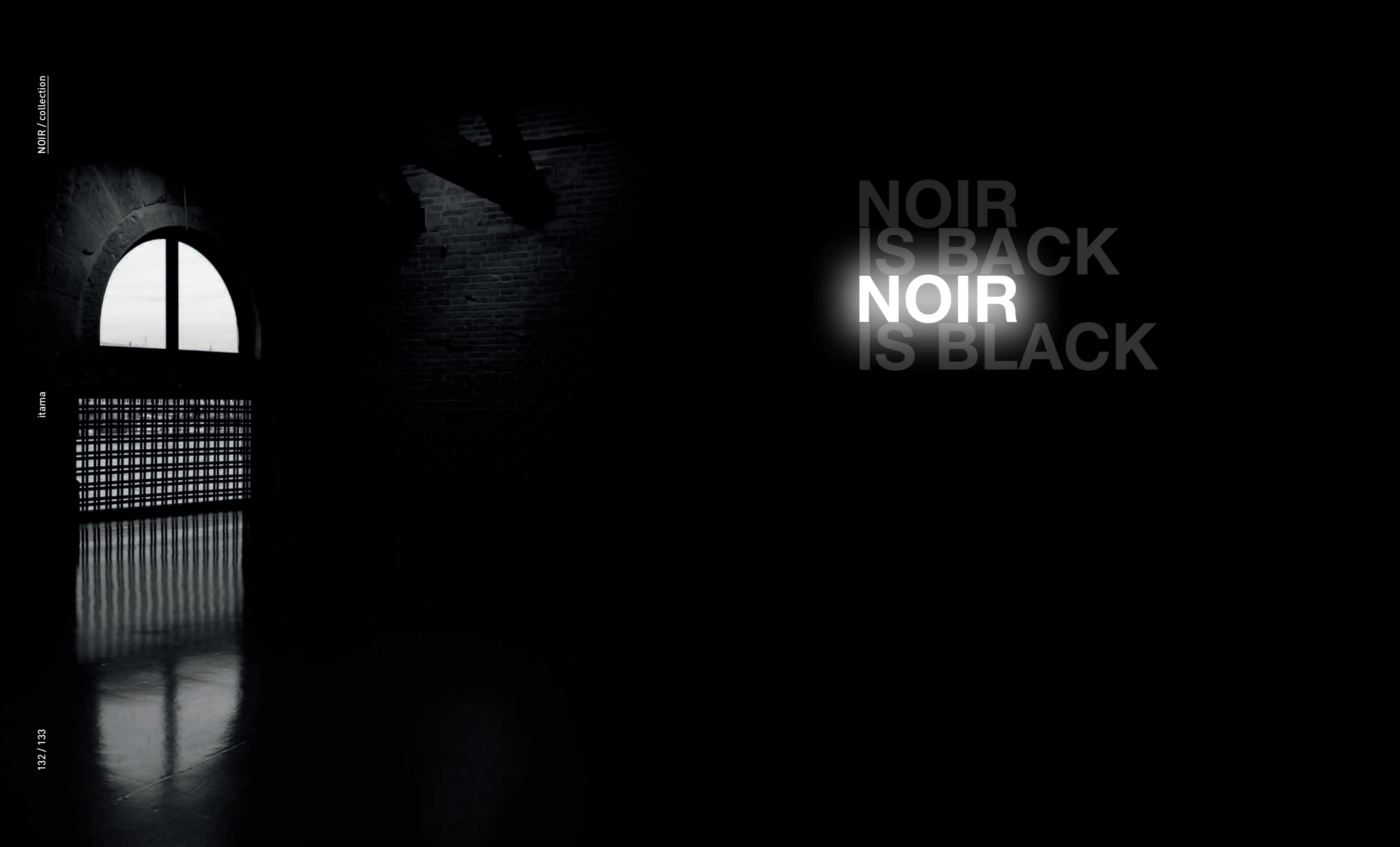

NOIR  
IS BACK  
**NOIR**  
IS BLACK

**SO 60**

suspension

**dimensions**

L 59.5 x W 59.5 x H 6 cm

**color**

red 3004

**SO 45**

suspension

**dimensions**

L 45 x W 45 x H 6 cm

**color**

red 3004

**NOIR** collection

[En] → **Geometries of light.** From the elegance and scrupulous geometry of the light-source, a light shines, strongly downwards and softly upwards. The architectural design of the object, that presents itself as a simple square with a window of light cut into it, is enriched by the different color options. The wall sconce declares essential minimalism by blending into the wall as an architectural element that stands out thanks to its luminous reflection.

**Geometrie di luce**

[It] → Dall'eleganza ed il rigore geometrico della lampada, scaturisce una luce diretta verso il basso e diffusa verso l'alto. Il design architettonico dell'oggetto, che si presenta come un semplice quadrato in cui è intagliata una finestra luminosa, è arricchito e valorizzato dalle diverse tonalità. La versione applique dichiara la sua essenza minimale, integrandosi alla parete come elemento architettonico che si distingue grazie all'effetto luminoso riflesso.

**Lichtgeometrien**

[De] → Aus der Eleganz und der geometrischen Strenge der Lampe ergibt sich ein direktes Licht nach unten und verteilt es nach oben. Die architektonische Gestaltung des Objektes, das wie ein einfaches Quadrat aussieht, auf dem ein helles Fenster geschnitzt ist, wird von verschiedenen Farbtönen bereichert und erweitert. Die Wandleuchte zeigt ihre Wesentlichkeit und Ihren minimalen Kern und integriert somit die Wand als architektonisches Element.

**Геометрия Света**

[Ru] → Эта элегантная и геометрически строгая лампа распространяет прямой свет вниз и рассеивающий вверх. Архитектурный дизайн лампы, которая представляет из себя простую квадратную форму с вырезанной освещенной частью, обогащается и усиливается разными цветовыми тональностями. Минималистичная форма бра подчеркивает сущность этой модели, интегрируясь со стеной как архитектурный элемент, выделяющийся благодаря эффекту отраженного света.

(نوار)  
هندسة الضوء :

[Ar] → عبارة عن ثرية مربعة مقسومة من الوسط مربع، تضيئ ألوان مختلفة من الجهتين، أصبحت أكثر ثراء من خيارات الألوان المختلفة. والشمعدان الجداري يعلن بساطته الأساسية عن طريق المزج في الحائط كعنصر معماري.

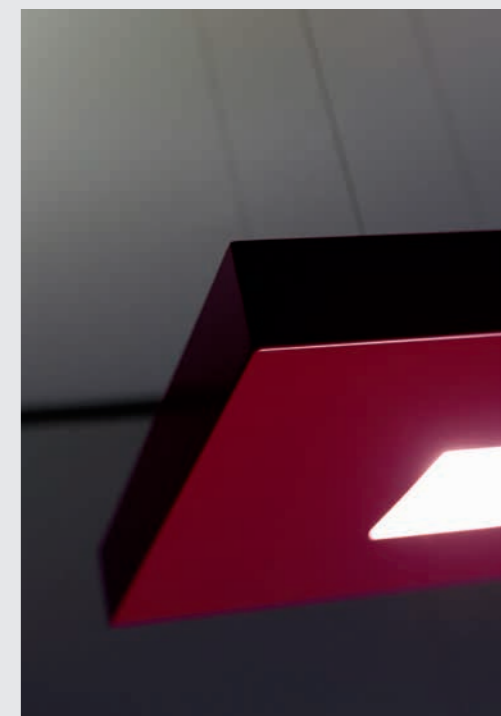





**SO 60**  
suspension

**dimensions**  
L 59.5 x W 59.5 x H 6 cm

**color**  
dove 1019



**AP**  
wall lamp

**dimensions**  
W 14.5 x DPT 15.5 x H 4 cm

**color**  
white 9010



[En] → The indirect lighting sources are shielded by two bands in satin finish PMMA, complementing the geometry of the lighting fixture.

[It] → Le sorgenti luminose che direzionano la luce verso l'alto sono schermate da due fasce in PMMA satinato che completano la geometria della lampada.



## **NOIR**

**S0 60**  
suspension

**dimensions**  
L 59.5 x W 59.5 x H 6 cm

**color**  
grey 7031



**NOIR**

AP  
wall lamp

dimensions  
W 14.5 x DPT 15.5 x H 4 cm

color  
white 9010







## NOIR collection

design Massimo Tonetto

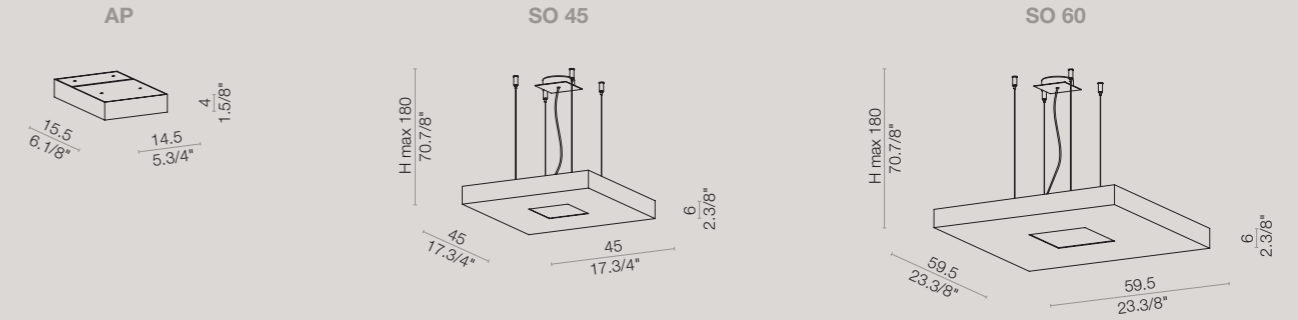

[En] → Powder-coated metal structure available in 5 colors. Direct and indirect light for the hanging version. Satin-finish PMMA diffusers. Only indirect light for the wall version.

[It] → Struttura in metallo verniciato a polveri nei 5 colori disponibili. Doppia emissione luminosa per la versione a sospensione. Diffusori in PMMA satinato. Singola emissione luminosa per la versione a parete.

## material

metal  
metallo

## light source

LED 220-240V

120V for  
NORTH AMERICA

Dimmer not included  
Dimmer non incluso

## equipment

## AP

21W LED 3000°K lm1850

## SO 45

21W LED 3000°K lm1850+  
20W LED 3000°K lm1780

## SO 60

30W LED 3000°K lm2200+  
40W LED 3000°K lm3560

## symbols

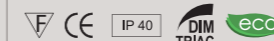
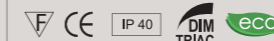

## photometric test AP

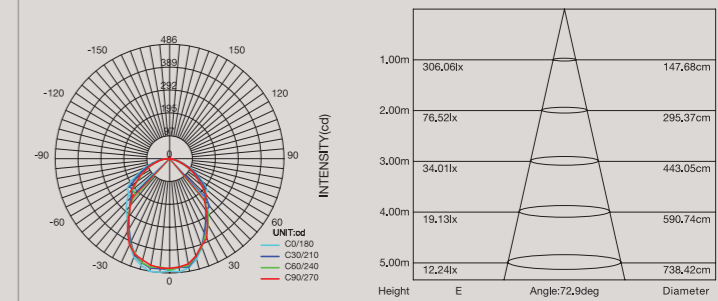

## photometric test SO 60

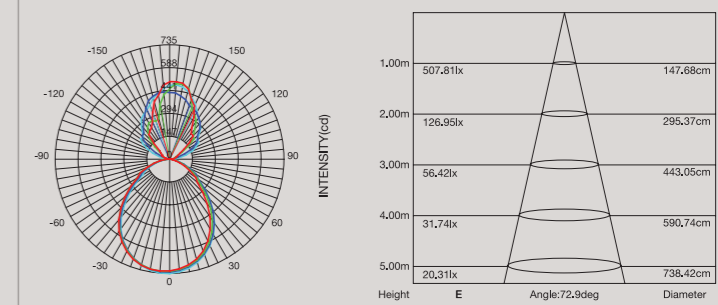

BE  
THE  
ONLY  
ONE





## ONE collection

[En] → **The functionality of shape.** A simple rectangle, softened by rounded corners and a variety of colors, used also to protect the light-source. This simple gesture, similar to the spontaneous act of putting a hand in front of your eyes to protect them from sunlight, makes ONE a functional and essential design piece.

### La funzionalità della forma

[It] → Un semplice rettangolo, ingentilito da angoli arrotondati e molteplici colorazioni, è posto a protezione della sorgente luminosa. Questo gesto, simile all'atto spontaneo di porre la mano davanti agli occhi per proteggersi dalla luce del sole, fa di ONE un oggetto funzionale ed essenziale.

### Die Funktionalität der Form

[De] → Ein einfaches Rechteck wird durch abgerundete Ecken und mehrere Farben aufgeweicht und dient dazu, die Lichtquelle zu schützen. Diese Geste, wie ein spontaner Akt die Hand über die Augen zu legen, um vor Sonnenlicht zu schützen, macht ONE zu einem funktionellen Objekt von wesentlicher Bedeutung.

### Функциональность формы

[Ru] → Форма простого прямоугольника, с чуть закругленными углами и разнообразными цветовыми решениями, обеспечивает защиту от светового источника. Это как спонтанный жест защитить себя от солнца прикрывая глаза рукой... Чистота линий делает модель ONE функциональной и простой.

### ون وظائف الشكل

[Ar] → منتج يمثل البساطة و الابتكار في أوجهه ; شكل مستطيل بزوايا مدورة أنيقة بالوانها ، تضيفي البهجة كما و تحمي ببساطة مصدر الضوء.

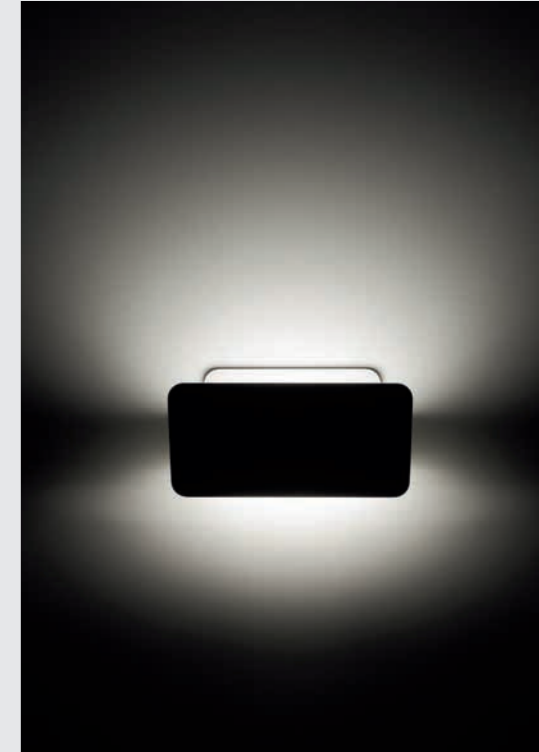





[En] → The inclination of the front reflector produces an asymmetric reflection, allowing the indirect light to be more effective than direct light.

[It] → L'inclinazione dello schermo frontale produce un riflesso asimmetrico della sorgente luminosa, permettendo alla luce di essere distribuita maggiormente verso l'alto e in modo più discreto verso il basso.

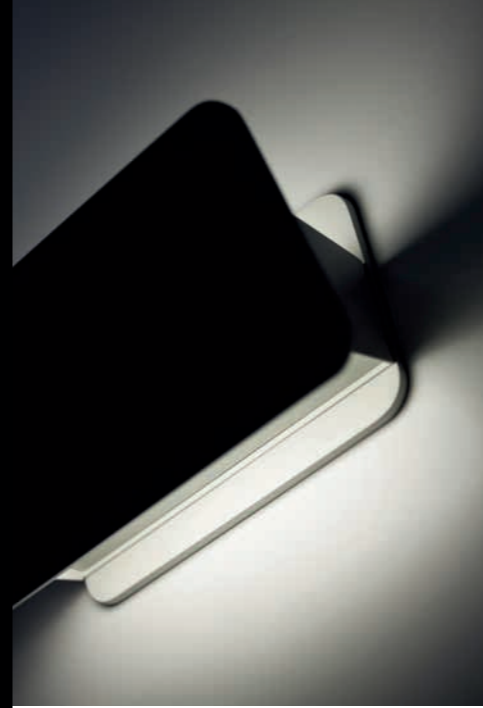

## ONE

AP  
wall lamp

dimensions  
W 22.5 x H 13 x DPT 11 cm

color  
white 9010

**ONE** collection

design Massimo Tonetto



[En] → 5 mm thick powder-coated front metal reflector, available in 4 colors. RAL 9010 back reflector and side bands powder-coated white RAL 9010. The LED lighting source 220-240V is installed in the middle of the lighting fixture and generates a double light emission controlled by the tilt of the frontal reflector.

[It] → Schermo frontale in metallo sp. 5 mm verniciato a polveri nei 4 colori disponibili. Schermo a parete e bande laterali in metallo verniciati a polveri bianco RAL 9010. La sorgente luminosa a LED 220-240V collocata al centro della lampada crea una doppia emissione regolata dall'inclinazione dello schermo frontale.

**material**metal  
metallo**light source**

LED 220-240V

120V for  
NORTH AMERICADimmer not included  
Dimmer non incluso**equipment**

13.5W LED 3000°K lm1450

Available 4000°K /  
Disponibile 4000°K**symbols****dimensions**

AP

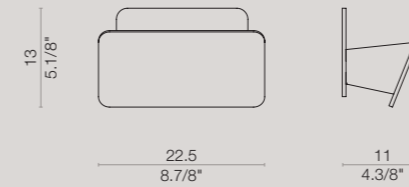
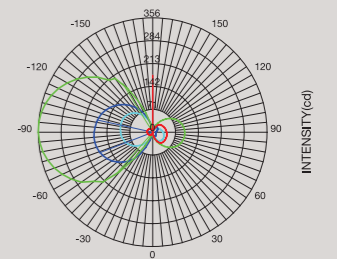
**photometric test ONE AP**

AVERAGE BEAM ANGLE(50%):215,2 DEG

**colors**white / bianco  
RAL 9010dove / tortora  
RAL 1019grey / grigio  
RAL 7031black / nero  
RAL 9005

# INFINITE SHADES OF LIGHT









## ITASHADES collection

[En] → **The lampshade with a more contemporary take.** Technological innovation has made it possible for us to move the light-source from the center of a lamp to its perimeter. This simple opportunity has given us the chance to create a new archetype for the traditional lampshade, a very low profile and a very lightweight look as the center of the shade can be hollow and freed of all technical limitations previously imposed by lamp technology. The result is an object that is distinguished by its simplicity and purity that declares its hi-tech personality once illuminated.

### Il paralume rivisitato in chiave contemporanea

[It] → L'innovazione tecnologica ha reso possibile lo spostamento della sorgente luminosa dal centro della lampada al perimetro della stessa. Questo semplice gesto ha dato forma a un nuovo archetipo del classico paralume in tessuto di altezza molto contenuta in cui il centro viene liberato da qualsiasi elemento tecnico. Il risultato è un oggetto che si distingue per la sua semplicità e purezza formale che dichiara il suo carattere hi-tech una volta illuminato.

### Der Lampenschirm in einem zeitgenössischen Stil überarbeitet

[De] → Technologische Innovation ermöglicht es, die Lichtquelle von der Mitte der Lampe auf den Umfang zu bewegen. Das Zentrum wurde von jedem technischen Element befreit. Das Ergebnis ist ein Objekt, das durch seine Einfachheit und Reinheit der Form besticht und sofern es beleuchtet ist seinen Hi-Tech Charakter zeigt.

### Абажур в его современном прочтении

[Ru] → Технологические инновации позволили передвинуть источник света с его центрального классического положения в периметр лампы. Эта возможность обрела форму в новом типе классического абажура в ткани, где центральная часть освобождается от всех технических элементов. Результат – лампа, отличающаяся простой и чистой формой и демонстрирующая свой хай-тек характер как только мы ее включаем.

ايتاما شدن

[Ar] → جعل هذا الابتكار التكنولوجي من الممكن بالنسبة لنا تحريك مصدر ضوء من مركز المصباح لمحيطها. أعطانا هذا الفرصة لخلق النموذج الأصلي الجديد لعاكس الضوء التقليدي، خفيفة الوزن جدا كمرکز للظل.



[En] → The care for details in ITASHADES is also evident in the joining of the inner white shade. The joining is covered by a steel plate in which there is the photo-etched ITAMA logo which helps to enhance the object and make the lamp precious.

[It] → La cura dei dettagli in ITASHADES si osserva anche nella giunzione del paralume interno, coperta da una targa in acciaio fotoinciso in cui è presente il logo ITAMA che contribuisce a valorizzare e rendere preziosa la lampada.



## **ITASHADES**

**IS RE S0 150**

suspension

**dimensions**

L 150 x W 45 x H 10 cm

**color**

green 66.8003.43



**ITASHADES****IS RE SO 90 / IS RE SO 120**

suspension

**dimensions**L 90 x W 45 x H 10 cm  
L 120 x W 45 x H 10 cm**colors**dove 66.8003.82  
white 66.8003.11**ITASHADES****IS SQ SO 100**

suspension

**dimensions**

L 100 x W 100 x H 10 cm

**colors**purple 66.8003.28  
brown 66.8003.52

[En] → ITASHADES is available in circular, square and rectangular shapes. All the versions, regardless of the shape or size, have a minimal height of ten centimeters and rounded corners.

[It] → ITASHADES è disponibile nelle forme circolare, quadrata e rettangolare. Tutte le varie versioni, a prescindere dalla forma o dalla dimensione, hanno sempre un'altezza contenuta di dieci centimetri e angoli arrotondati.

[En] → The outer lampshade is covered with cotton that is hemmed around the frame, to ensure a clean edge. That same edge, becomes a supporting element for the inner lampshade, which is the real diffuser of the lamp.

[It] → Il paralume esterno è rivestito in tessuto di cotone che viene ribordato attorno al telaio, in modo da garantire la pulizia del bordo. Lo stesso bordo, diventa l'elemento d'appoggio al paralume interno che è il diffusore della lampada.



## **ITASHADES**

**IS SQ SO 70**  
suspension

**dimensions**  
L 70 x W 70 x H 10 cm

**colors**  
green 66.8003.43  
blue 66.8003.14

[En] → The ITASHADES collection is available in seven colors. All shades come in a range of soft and contemporary colors that fit discreetly into any context.

[It] → La collezione ITASHADES è disponibile in sette colorazioni. Tutte le tonalità rientrano in una gamma di colori tenui e contemporanei che si adattano in modo discreto ad ogni contesto.

white	dove	green	blue	brown	purple	bordeaux
66.8003.11	66.8003.82	66.8003.43	66.8003.14	66.8003.52	66.8003.28	66.8003.09







## ITASHADES

IS CY SO 70  
suspension

dimensions  
Ø 70 x H 10 cm

color  
brown 66.8003.52

[En] → All models have a prismatic PMMA cover. This element shields the light source and diffuses the light uniformly upwards, it also prevents dust accumulating in the fitting.

[It] → Tutti i modelli, hanno una copertura in PMMA prismatico. Questo elemento oltre a chiudere la parte superiore della lampada impedendo che si accumuli lo sporco, scherma la sorgente luminosa e diffonde la luce in modo uniforme verso l'alto.

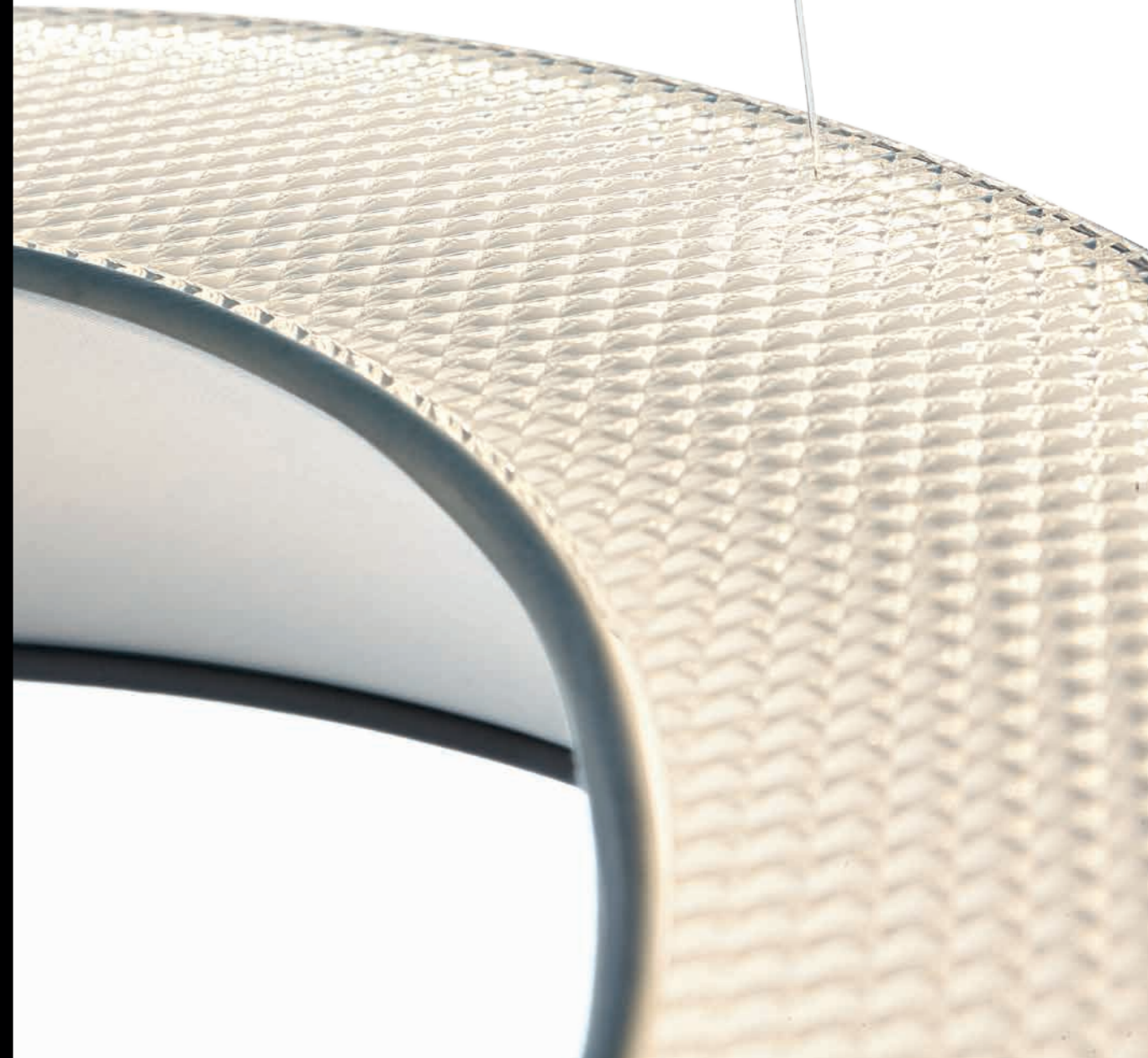

IS CY SO 50

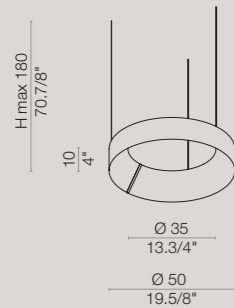

IS CY SO 70

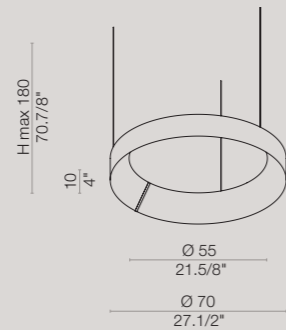

IS CY SO 100

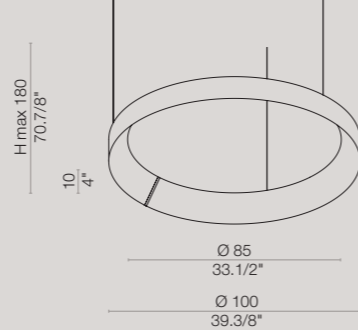

IS SQ SO 50

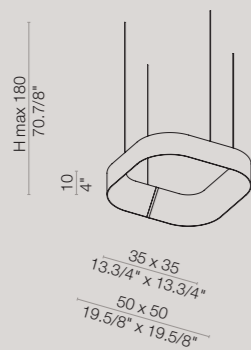

IS SQ SO 70

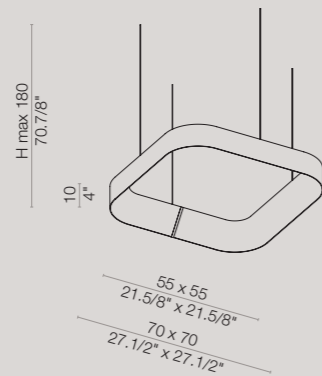

IS SQ SO 100

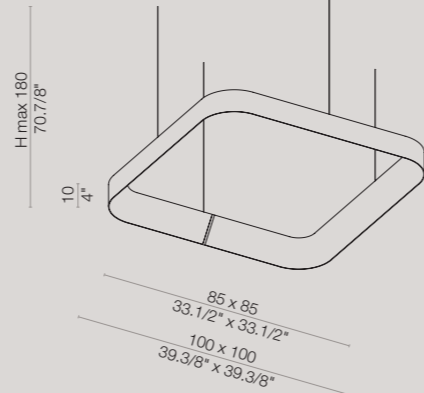

IS RE SO 90

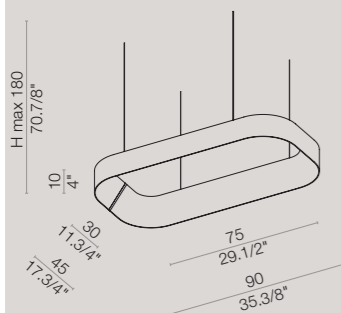

IS RE SO 120

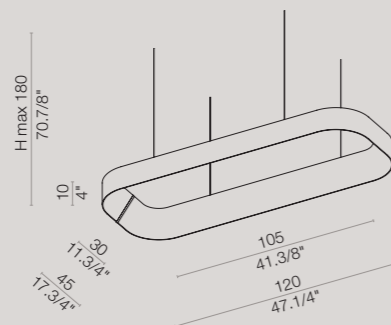

IS RE SO 150

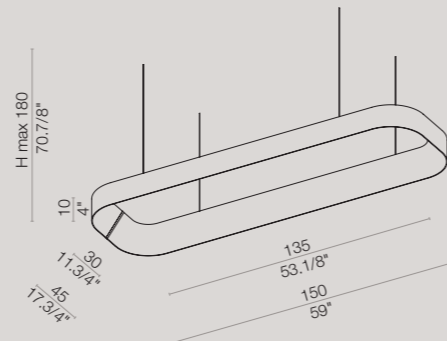

## ITASHADES collection

design Lorenzo Bertocco



## material

fabric + PVC  
tessuto + PVC

## light source

LED 220-240V

120V for  
NORTH AMERICA

## photometric test IS CY SO 50

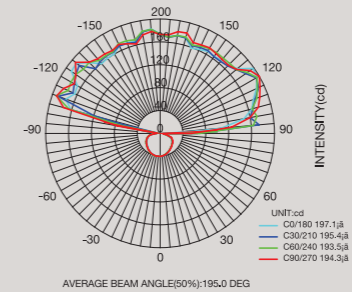

## colors

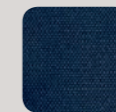
white / bianco  
66.8003.11dove / tortora  
66.8003.82green / verde  
66.8003.43blue / blu  
66.8003.14brown / marrone  
66.8003.52purple / viola  
66.8003.28bordeaux  
66.8003.09

[En] → Unit composed by: outside shade in opaque PVC completed with cotton fabric available in 7 colors. Inside shade in transparent PVC completed with white cotton fabric. Prismatic PMMA cover. Strip LED 20W/m 24V.

[It] → Oggetto composto da: paralume esterno in PVC coprente accoppiato con tessuto cotone nei 7 colori disponibili e paralume interno in PVC traslucido accoppiato con tessuto cotone bianco. Copertura in PMMA prismatico. Sorgente LED Strip 20W/m 24V.

## equipment

## IS CY SO 50

31W LED 2700°K Im3390

## IS CY SO 70

44W LED 2700°K Im4750

## IS CY SO 100

62W LED 2700°K Im6690

## IS SQ SO 50

40W LED 2700°K Im4320

## IS SQ SO 70

56W LED 2700°K Im6050

## IS SQ SO 100

80W LED 2700°K Im8640

## IS RE SO 90

54W LED 2700°K Im5830

## IS RE SO 120

66W LED 2700°K Im7130

## IS RE SO 150

78W LED 2700°K Im8430

Available 4000°K /  
Disponibile 4000°KDimmerable LED driver  
available / Disponibile LED  
driver dimmerabile

## symbols



# OVERLAPPING BLACK AND WHITE SMOKE







## SMOKE collection

[En] → **Overlapping.** The apparently casual juxtapositioning of formless shapes gives birth to SMOKE. Sheets of white glass overlap, giving an interesting play of light and darkness that are appraised by the reflective surfaces of the diffusers. They are presented as independent elements and can be matched up in different positions opposite each other, creating a variety of shapes.



### Sovrapposizione

[It] → La giustapposizione apparentemente casuale di forme amorphe, dà vita a SMOKE. Lastre di vetro bianco si sovrappongono creando interessanti giochi di chiaro-scuro che sono valorizzati dalle superfici riflettenti dei diffusori. Essi si presentano come elementi indipendenti che possono essere accostati l'uno di fronte all'altro in diverse posizioni, rendendo possibili molteplici variazioni formali.

### Überlappung

[De] → SMOKE ist die scheinbar zufällige Überlagerung von amorphen Formen. Weiß überlappende Glasplatten schaffen ein interessantes Spiel von Licht und Dunkelheit, das durch die reflektierenden Oberflächen der Diffusoren verstärkt wird.

### تداخل

[Ar] → من مجموعة اشكال غير محدودة. SMOKE تولد صفائح الزجاج الأبيض تتداخل إعطاء مسرحية مثيرة للاهتمام للضوء والظلام. وقد يتم تقييمها من قبل السطوح العاكسة. يتم به كعناصر مستقلة، ويمكن تتقابل حتى في المواقف المختلفة على عكس بعضها البعض. خلق مجموعة متنوعة من الأشكال مستقلة ويمكن أن يقابل حتى في المواقف المختلفة عكس بعضها البعض. هكذا خلق مجموعة متنوعة من الأشكال

### Перекрывающиеся формы

[Ru] → По-видимому случайное сопоставление различных аморфных форм дает жизнь модели SMOKE. Перекрывающиеся друг друга белые стеклянные пластины, создают непередаваемую игру света и тени. Этот эффект достигается за счет отражающих поверхностей рассеивателей, представляющих из себя отдельные элементы, которые могут быть сдвинуты один относительно другого для достижения максимально большого количества форм.







**SMOKE**

AP/PL 60  
wall or ceiling lamp

dimensions  
W 60 x DPT 12 cm



[En] → Despite the lamp is totally open to the sides, the light source is not visible, because it is covered by a prismatic PMMA element.

[It] → Nonostante la lampada sia totalmente aperta lateralmente, la sorgente luminosa non è a vista in quanto coperta da un elemento in PMMA prismatico.



**SMOKE** collection

design Massimo Tonetto



[En] → Flat glass panels shaped and decorated in white color can be installed at wish creating various compositions. The 50 AP/PL model has 2 glasses and the 60 AP/PL model has 3 glasses. All glasses are held by a powder-coated front metal detail, in white RAL 9010. LED 220-240V installed at the back of the fitting and screened by prismatic PMMA.

[It] → Lastre in vetro piano sagomato decorato bianco montate a piacimento creano diverse composizioni. La versione 50 AP/PL utilizza 2 vetri, nella versione AP/PL 60 invece 3. I vetri vengono tenuti da particolare frontale in metallo verniciato a polveri bianco RAL 9010. Sorgente LED 220-240V collocata lato parete con copertura in PMMA prismatico.

**material**

glass and metal  
vetro e metallo

**light source**

LED 220-240V  
120V for  
NORTH AMERICA  
Dimmer not included  
Dimmer non incluso

**equipment**

**AP/PL 50**  
31W LED 3000°K lm2700  
**AP/PL 60**  
38W LED 3000°K lm3000

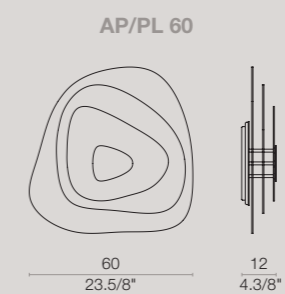
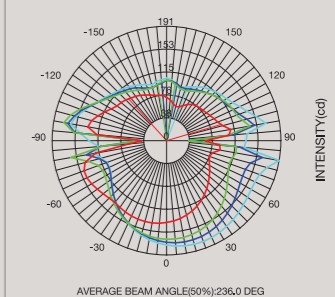
**symbols****dimensions****photometric test SMOKE PL 60**





MORE  
THAN  
A LIGHT  
MULTI4



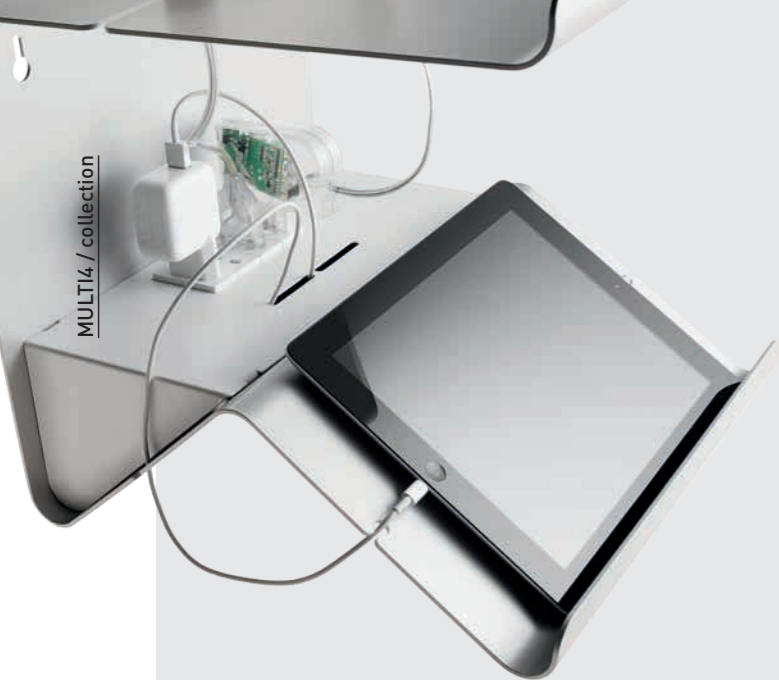

## MULTI4 collection

[En] → **Simply usefull.** The Multi4 platform is an ergonomic multifunctional furnishing accessory; a simple and safe shelf, on which mobile phones, tablets and other small hi-tech electronic devices can be recharged.

### Semplicemente utile

[It] → La piattaforma Multi4 è un oggetto d'arredo multifunzionale dal design ergonomico che permette un facile e sicuro piano d'appoggio e ricarica per cellulari, tablet e qualsiasi altro piccolo apparecchio elettronico hi-tech.

### Einfach sinnvoll

[De] → Die Multi4 Plattform ist ein ergonomischer Multifunktionseinrichtungs Accessoire; eine einfache und sichere Ablage, auf der Handys, Tablets und andere kleine hallo-Tech-elektronische Geräte wieder aufgeladen werden können.

### Просто полезным

[Ru] → Платформа Multi4 это многофункциональный аксессуар эргономичного дизайна, являющийся простой и безопасной опорной поверхностью и одновременно местом зарядки для мобильных телефонов, планшетов и любых других небольших электронных устройств хай-тек.

### ببساطة مفيدة

[Ar] → هو مريح تائيث متعدد الوظائف . انه رف بسيط وآمن، وعليه MULTI4 منصة فوضع الهواتف وغيرها من الأجهزة الإلكترونية الصغيرة خاصة بالتكنولوجيا الفائقة التي يمكن إعادة شحنها.





[En] → Multi4 can be used as a simple floor-standing base unit or easily fastened to any wall. With its two slots it's possible to connect a small lampshade or a flexible reading LED lamp. It has a power strip for simultaneously recharging several electronic devices, with cable ducting to keep wires tidy. Curved aluminium makes the Multi4 platform strong and long-lasting. A quality top-design product entirely made in Italy.

[It] → Multi4 può essere utilizzato come semplice base a terra o fissato a muro ed è provvisto di due incavi ai quali è possibile agganciare un piccolo abat-jour e/o un flessibile led da lettura. È dotato di multipresa per la ricarica contemporanea di più apparecchi elettronici e di passacavi per dare ordine all'intreccio di fili. L'utilizzo dell'alluminio curvato lo rende forte e durevole nel tempo. Un prodotto di qualità e di design interamente realizzato in Italia.

**MULTI4** collection

design Brian Rasmussen

## colors

white / bianco  
RAL 9010black / nero  
RAL 9005brown / marrone  
RAL 8016red / rosso  
RAL 3020grey / grigio  
RAL 9006

## accessories

paralume  
lampshade lamplampada led flessibile  
flex led reading lamp

## description

4-Way Multi-Socket  
Multi presa elettrica 4 postiUS and UK standards  
available on request

## material

aluminium  
alluminio

## equipment

**LAMPSHADE LAMP**1 x max 42W E14  
1 x max 12W E14  
1 x 5W LED E14 220-240V 2700°K lm350**FLEX LED READING LAMP**

1,2W LED 3000°K lm120

**STRUCTURE**

## symbols



## dimensions

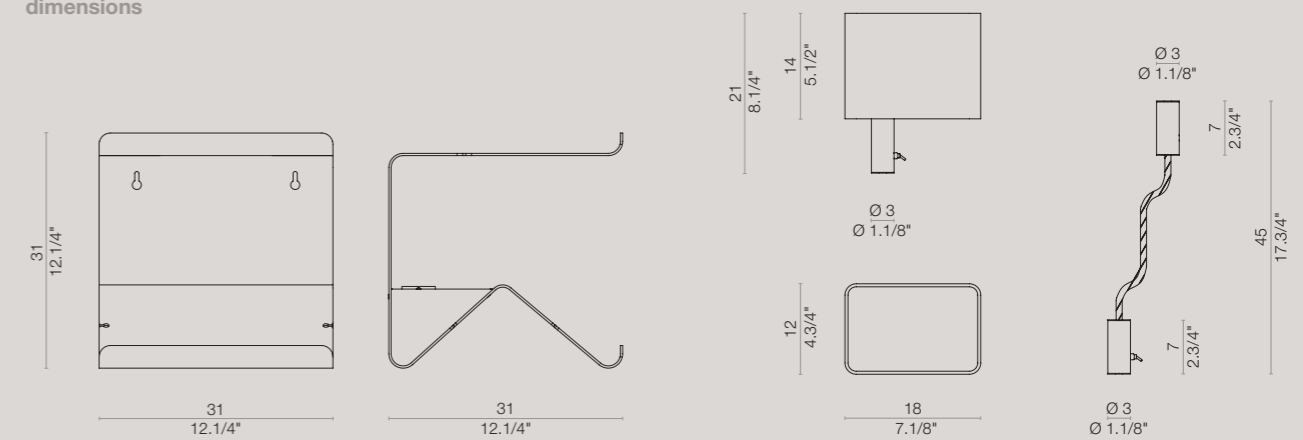





# COLORS AND FABRICS



**ITAMA COLORS**



white / bianco  
RAL 9010

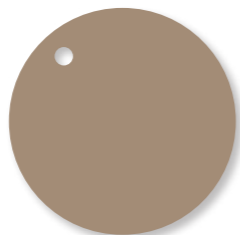

dove / tortora  
RAL 1019

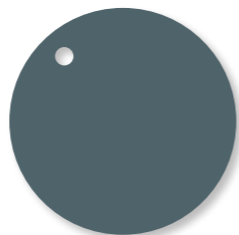

grey / grigio  
RAL 7031

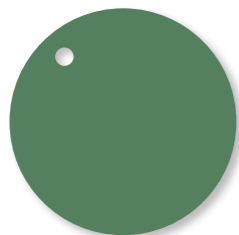

green / verde  
RAL 6011

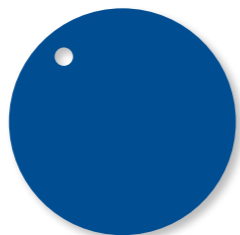

blue / blu  
RAL 5005

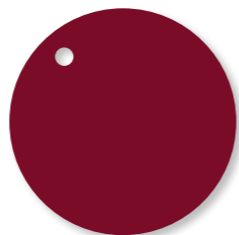

red / rosso  
RAL 3004

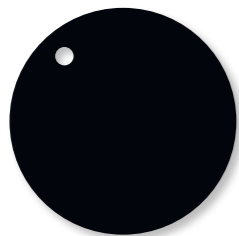

black / nero  
RAL 9005



concrete / cemento



chrome / cromo

**MULTI4 COLORS**



white / bianco  
RAL 9010



black / nero  
RAL 9005

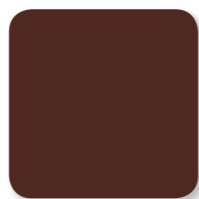

brown / marrone  
RAL 8016



red / rosso  
RAL 3020



grey / grigio  
RAL 9006

**ITAMA FABRICS**



66.8003.11 white / bianco



66.8003.82 dove / tortora



66.8003.43 green / verde



66.8003.14 blue / blu



66.8003.52 brown / marrone



66.8003.28 purple / viola



66.8003.09 bordeaux

itama by

**LIGHT4**

LIGHT4 srl viale dell'industria, 2A - 31055 quinto di treviso (tv) - italia  
t. +39 0422 378122 - t. +39 0422 475009 - f +39 0422 370409  
www.itamaluce.com - www.light4.it - info@light4.it

dom

