

luz e forma

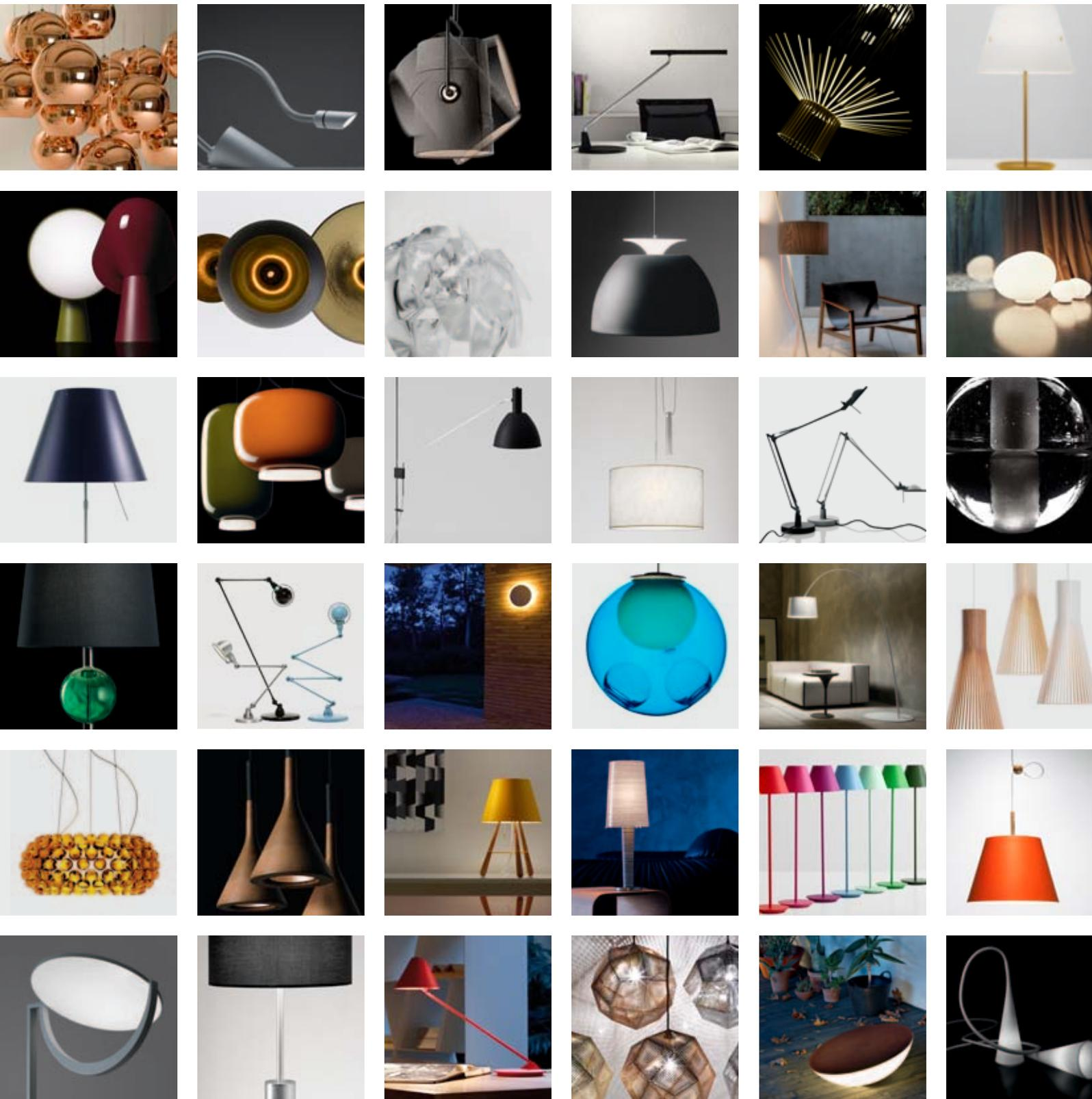

luz e forma

lumini
soluções em
iluminação

índice



apresentação

- 18 lumini
- 32 barovier Et toso
- 36 bocci
- 38 diesel
- 40 foscari
- 42 jieldè
- 44 luceplan
- 46 tom dixon



50 360°



62 bocci 14



76 copper shade

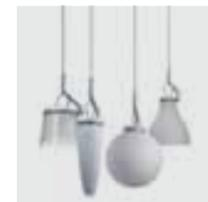

84 glassglass



94 lightweight



102 planet



109 tite



120 void light



52 alegretto



63 bocci 28



78 constanza

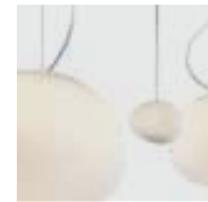

85 gregg



95 maki



103 plissé



110 tool



121 wave



53 alegro



66 bossa



79 constanzina



86 havana



96 mirror ball



104 quadratta

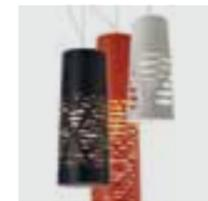

111 tress



124 wish



54 aplomb



70 caboché



80 etch shade



87 hope



97 o-space



105 rock



114 twiggy



56 beat



74 cage



82 fork



90 joy



100 piccolo



106 secto



115 uto



58 big bang



75 chouchin



83 glas



92 le soleil



101 pipe light



108 theodora



116 vinte2



arandelas

luz difusa



130 base light



137 havana



143 tress

leitura



146 bauhaus 90



153 led it be



aplicadas



158 blow



165 trama



mesa

luz difusa



172 anisha



182 birdie



131 bocci 14



138 hope



148 berenice



159 bocci 14



166 twiggly



173 atollo



184 cage



132 caboche



139 kite



149 duii

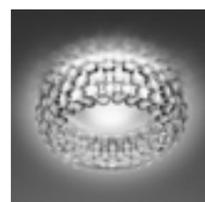

160 caboche



174 baju



185 constanza



133 constanzina



140 metropoli



150 fortebraccio



161 gregg



175 base light



186 constanzina



134 eclipse



141 piccolo



151 glassglass



162 luna



176 behive



187 esa 07



136 gregg



142 trama



152 jieldé signal



164 metropoli



178 binic



188 fool



192 fork



198 ovale



207 vinte2



218 bauhaus 90

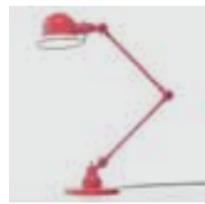

232 jieldé loft



piso



244 base light

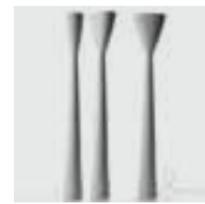

256 carrara



263 giga lite



271 lift



283 pipe



292 uto



193 glas



199 piccolo



212 wish



222 berenice



233 jieldé signal



245 bauhaus 90



258 costanza



264 gregg



274 luna



284 rock



293 wish



194 gregg



200 piccolo R



224 bill



234 led it be



250 berenice



259 fatspot

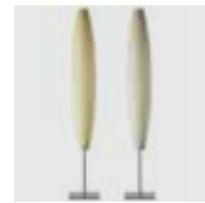

265 havana



278 magneto



285 solar outdoor



195 lite



204 pipe



226 duii



236 pett



251 birdie



260 fina

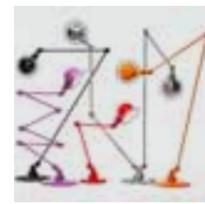

268 jieldé loft



279 mirror ball



286 tress



196 lumiere 05



205 secto



227 fortebraccio



237 pixell



254 bridge



261 fork



269 jieldé signal



280 mite



287 tri-p



197 lumiere xx



206 tua



228 ginga



240 twiggy



255 cage



262 fortebraccio



270 joy



282 piccolo

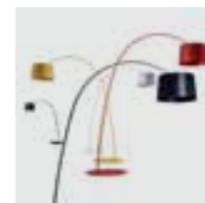

288 twiggy

especificações



296
360°



296
linha allegro + allegretto



298
linha anisha



298
aplomb



299
atollo



299
baju



299
linha base light



300
linha barovierftoso



304
linha bauhaus 90

305
linha beat



306
behive

307
linha berenice

308
big bang



308
bill



312
linha bocci 28



313
linha bossa

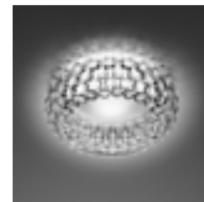

317
linha cage



321
linha costanza



309
binic



313
blow



314
bridge



315
linha caboche



318
carrara



323
linha costanzina



309
linha birdie

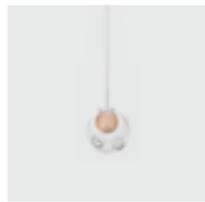

310
linha bocci 14



317
linha cage



319
linha chouchin



320
linha copper

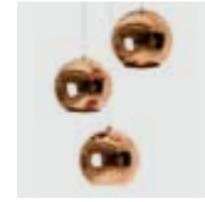



324
linha duii



326
etch shade



329
linha fortebraccio



332
linha glassglass



336
linha havana

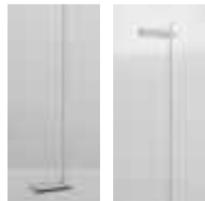

327
fina

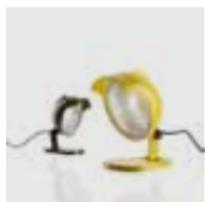
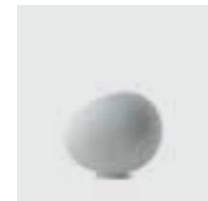

327
linha fool



333
linha gregg

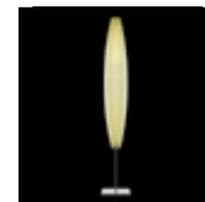

325
linha eclipse



337
linha hope



328
linha fork



330
ginga



331
linha glas



326
linha esa





338
linha jieldé loft



341
linha joy



343
linha lumiere



346
maki



348
linha mite



346
metropoli



342
le soleil



346
linha mirror ball



342
linha led it be

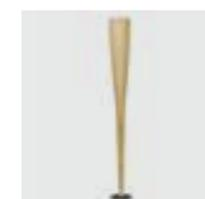

340
linha jieldé signal



345
linha luna



351
o-space



343
lift



351
ovalle T



343
lightweight



345
magneto



351
pett

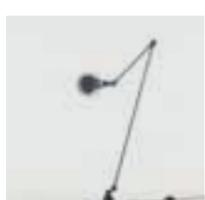



352
linha piccolo



354
pipe light



357
linha secto



359
trama



362
tua



364
linha vinte2



355
pixell



360
linha tress



362
linha twiggy



355
linha planet

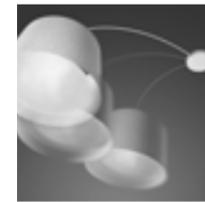

364
void light



358
solar outdoor

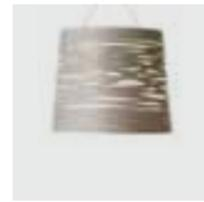

365
wave



356
plissé



358
theodora

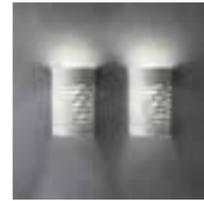

365
linha wish



354
linha pipe



356
quadratta



359
linha tool



356
linha rock



363
uto



361
tri-p





lumini

forma pura como
caminho para
a simplicidade

movimento
como experiência
sensorial

luz como
instrumento de
transformação
do espaço



mais que produzir
luminárias, nos destacamos,
há cerca de 35 anos,
por oferecer soluções
completas de iluminação
a nossos clientes



em luz e forma, o volume assume o protagonismo. luminárias com uma forte identidade conceitual e visual conferem personalidade aos ambientes. além das peças de fabricação própria – assinadas pelo premiado designer fernando prado e exportadas a mais de 30 países – a linha também apresenta produtos de marcas reconhecidas internacionalmente, como barovier&tosco, foscarini, tom dixon, luceplan e jieldé. um mix pensado para atender com perfeição às necessidades do usuário

nossa linha técnica – luz
e arquitetura – busca
a valorização do espaço
arquitetônico por meio
de produtos de alta
performance e resistência.
de embutidas a balizadores,
essas luminárias atendem
com eficiência às mais
específicas demandas





na LED solutions, nossa principal preocupação é apresentar soluções eficientes e com longa durabilidade. todos os componentes do projeto - do led à luminária - são desenvolvidos internamente e de forma integrada, garantindo assim conjuntos ópticos de alta qualidade

para completar, oferecemos o que há de melhor em automação, sistemas inteligentes de controle de iluminação conferem conforto e sofisticação a ambientes residenciais e corporativos





preparados para atender projetos arquitetônicos de qualquer formato e escala, contamos com showrooms em são paulo, campinas, rio de janeiro e brásilia, além de uma filial na alemanha. consultores de venda, técnicos e instaladores experientes assessoram o cliente em todas as etapas, garantindo um atendimento com o mesmo padrão de qualidade de nossos produtos

barovier & toso

sinônimo de tradição e excelência, a família barovier é pioneira na fabricação de cristais de murano em todo o mundo. um dos representantes da família – ângelo barovier – foi mestre de vidros na época do renascimento italiano e seu papel nesta arte é comparado à contribuição de leonardo da vinci para a pintura. com peças espalhadas por alguns dos mais importantes museus do mundo, barovier&toso combina técnicas centenárias e design contemporâneo para criar suas coleções

veja algumas luminárias barovier&toso na página 300





bocci



bocci é uma casa canadense de manufatura e design contemporâneo. devido à sua estrutura de trabalho atípica, a empresa se autodefine como uma comunidade de designers, arquitetos, artesãos e técnicos, que atua em conjunto para criar produtos inovadores e de excelente qualidade. com um apelo emocional e romântico, a bocci é conhecida internacionalmente por suas luminárias pendentes em vidro fundido e soprado



diesel

successful living é resultado da união das marcas italianas diesel e foscari. uma coleção de luminárias que fala vários idiomas, conta histórias diferentes e expressa um estilo inconfundível: o estilo de vida diesel. uma maneira de ser e de vestir, uma aventura que permite conferir personalidade à luz

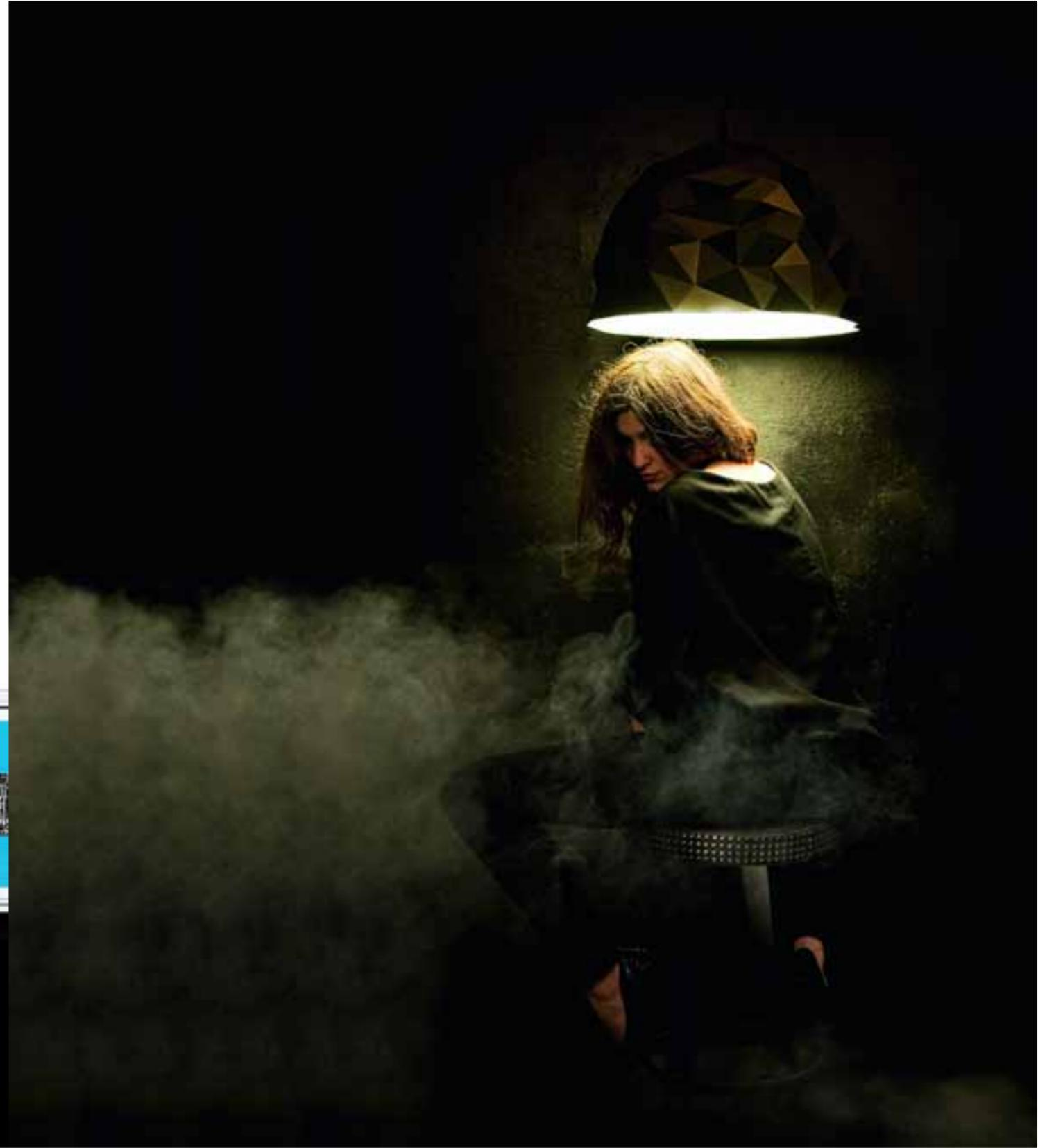

foscarini

a foscarini conta com parcerias de mestres renomados e jovens talentos do circuito internacional de design para criar diferentes produtos e proporcionar experiências únicas. é assim que a empresa desenvolve luminárias originais, caracterizadas pela singularidade de cada criador



jieldé

no final da década de 1940, jean-louis domeneccq desenhou uma luminária para atender as necessidades específicas de seu ofício como mecânico. a peça fez tanto sucesso que, em 1953, ele criou a marca jieldé com o propósito de comercializá-la. a partir da produção industrial, as luminárias foram sendo adaptadas a novas necessidades de aplicação e se transformaram em ícones da arte industrial francesa. ainda hoje, as peças são produzidas em lion de forma artesanal e numeradas individualmente, mantendo seu caráter único



luceplan

a luceplan se dedica, desde sua origem, a melhorar a qualidade de vida das pessoas por meio da criação e produção de luminárias comprometidas com a questão ambiental. a marca não se limita apenas à economia de energia; está atenta a todas as fases de desenvolvimento de suas peças - da escolha dos materiais ao processo de fabricação, durabilidade e manutenção. o resultado são produtos inteligentes e sofisticados, de elegância clássica e atemporal



tom dixon

fundada em 2002, tom dixon é uma empresa inglesa comprometida com o renascimento da indústria britânica de mobiliário e iluminação. inspirada na herança cultural de seu país de origem, tom dixon apresenta um design marcado pela constante renovação



pendentes

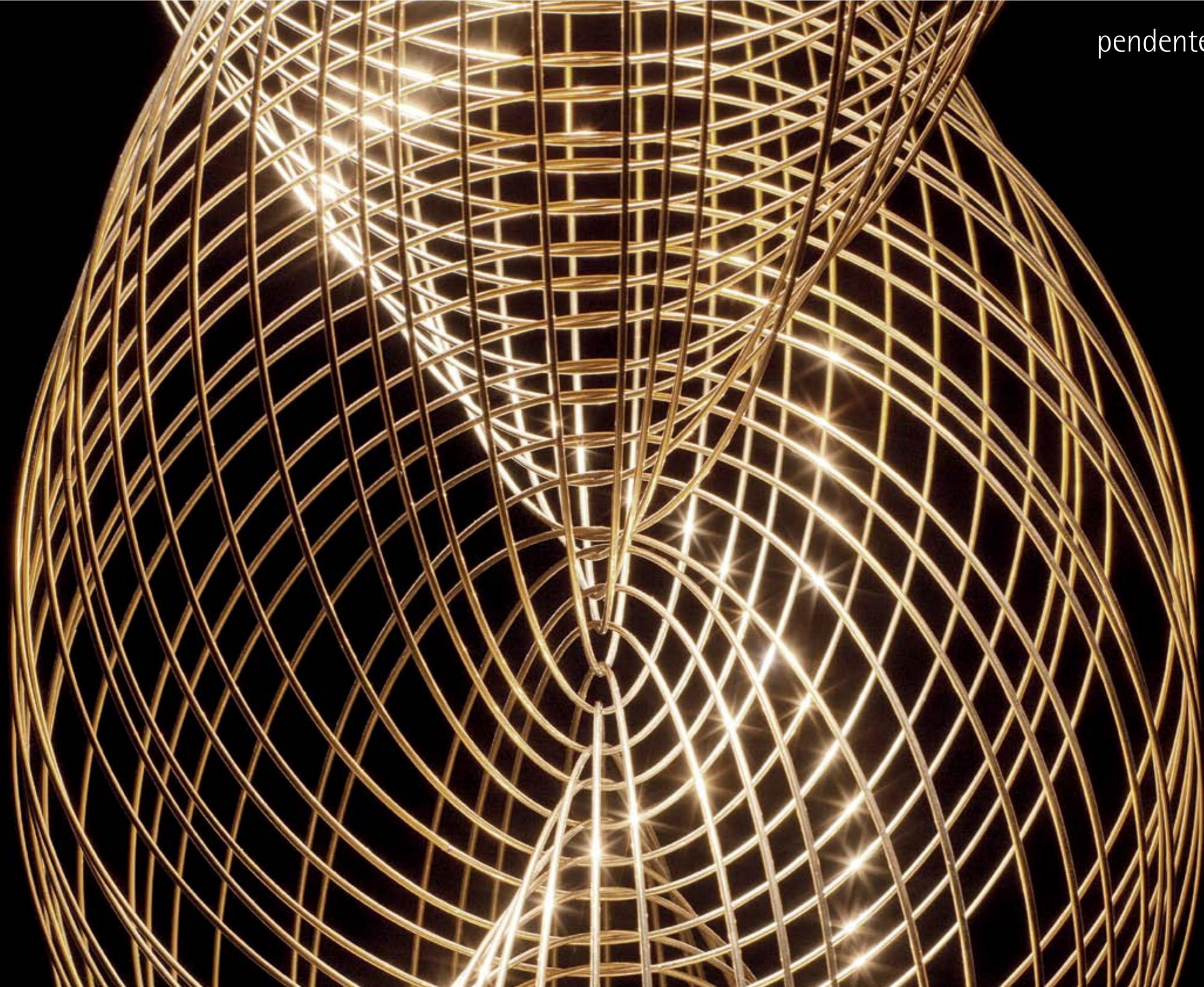



assinada por antonio bernardo, a luminária 360° foi inspirada em um projeto anterior do designer – o premiado brinco 360°. bernardo buscou dar uma nova escala e funcionalidade ao seu desenho. o resultado é uma obra de arte que trabalha forma e movimento a partir de argolas que giram 360°. confeccionado em aço inox, este pendente possui uma luz que projeta inúmeras formas no ambiente, criando uma sensação de vibração e tridimensionalidade únicas

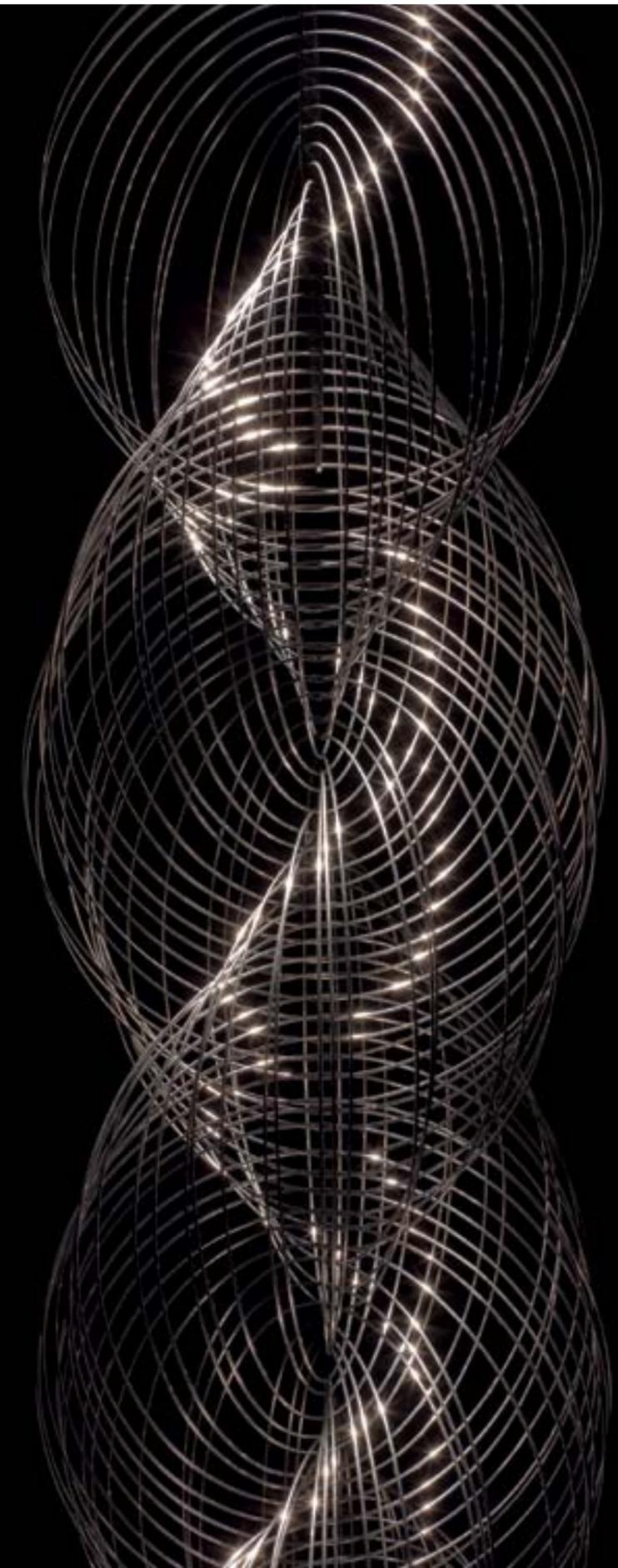

allegretto

design
atelier oï
fabricante
foscarini

especificações
pg 296



allegro



uma luminária, um instrumento musical, uma instalação. allegro e allegretto são resultado de um trabalho conjunto entre arquitetos e cenógrafos com o objetivo de criar uma obra de arte em escala industrial. com o desafio de utilizar materiais não transparentes para conseguir jogos de iluminação, as peças interpretam a luz de forma inédita e adquirem o papel de protagonista em qualquer ambiente

aplomb

design
lucidi
pevere
fabricante
foscarini

especificações
pg 298



o concreto aparente faz parte da linguagem da arquitetura moderna. lucidi e pevere incorporaram este conceito à aplomb com o desafio de realizar um enorme salto de escala: dos grandes projetos arquitetônicos a uma pequena luminária pendente. a peça foi desenvolvida com espírito e tecnologia originais, a partir de um concreto especial, que oferece um efeito ao mesmo tempo bruto e refinado

beat

design
tom dixon
fabricante
tom dixon

especificações
pg 305



inspirada na simplicidade escultural das tradicionais jarras de bronze usadas no norte da Índia, a linha beat é feita à mão por renomados artesãos da região de Moradabad. Essas luminárias emitem uma luz quente e agradável, graças ao contraste entre a superfície externa fosca e o interior dourado brilhante. Beat está disponível em quatro modelos de aplicação: pendente: fat, stout, tall e wide.



big bang

design
enrico Franzolini
vicente garcia jimenez
fabricante
foscarini

especificações
pg 308

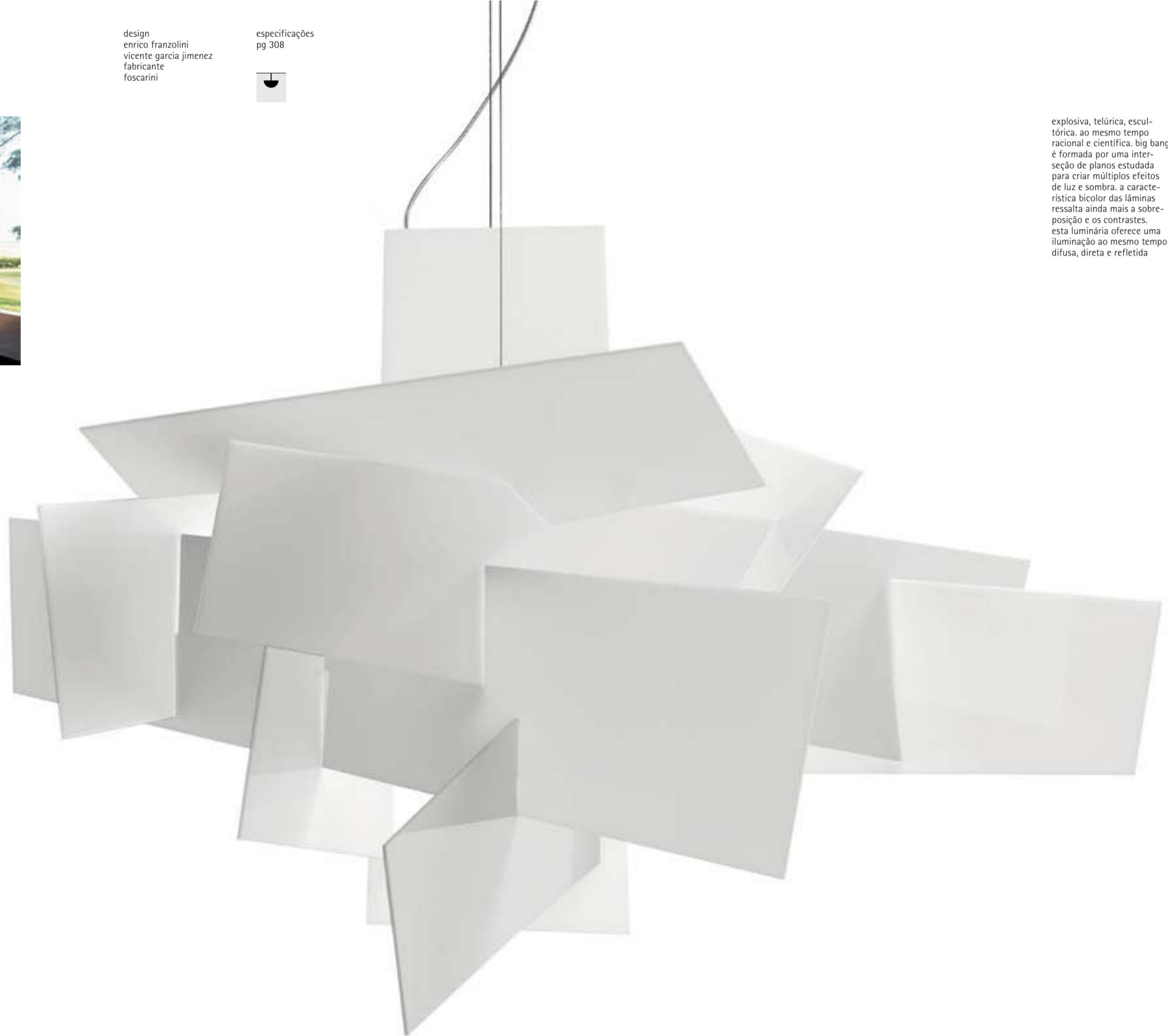

explosiva, telúrica, escultórica. ao mesmo tempo racional e científica. big bang é formada por uma interseção de planos estudada para criar múltiplos efeitos de luz e sombra. a característica bicolor das lâminas ressalta ainda mais a sobreposição e os contrastes. esta luminária oferece uma iluminação ao mesmo tempo difusa, direta e refletida



bocci 14

design
omar arbel
fabricante
bocci



especificações
pg 310



desenhada por omar arbel em 2005, esta luminária desafia o conceito original dos lustres, normalmente utilizados como peças centrais de um ambiente. 14 abandona a ideia do protagonismo escultural e aposta em uma estratégia de composição e volume para preencher o espaço. ela emite interessantes efeitos luminosos que resultam da interação entre a luz e as esferas de vidro fundido

bocci 28

design
omar arbel
fabricante
bocci



especificações
pg 312



28 explora as inúmeras possibilidades inerentes ao processo de fabricação de uma luminária. ao invés de projetar uma forma final, omar arbel optou por criar um sistema que produz formas. neste sistema, cada interação realizada no processo de fabricação tem impacto no objeto que está sendo criado. o resultado é uma peça exclusiva, composta por esferas de vidro transparentes e cavidades interiores brancas





prêmios
idea brasil
2008
idea usa
2008
if
2008
german design
2007
ida
2007
if gold
2007
red dot
2007
design plus
2006
good design
2006
mcb
2005
top XXI

as luminárias de fernando prado são conhecidas e admiradas pela interação que propõem ao usuário. exemplo disso é bossa, contemplada com alguns dos mais importantes prêmios de design do mundo. seu sistema de iluminação permite a mudança de efeitos e o controle de intensidade da luz através da movimentação de seu refletor. produzida em alumínio, bossa está disponível em diferentes tamanhos e acabamentos



lumini

caboche

design
eliana gerotto
patricia urquiola
fabricante
foscarini

especificações
pg 315



caboche surgiu dos olhares de patricia urquiola e eliana gerotto a uma pulseira de pérolas. a partir de uma estrutura de arco modular e pequenas esferas de polimetilmetacrilato, as designers conseguiram uma luz pura que se difunde como cristais luminosos no ambiente

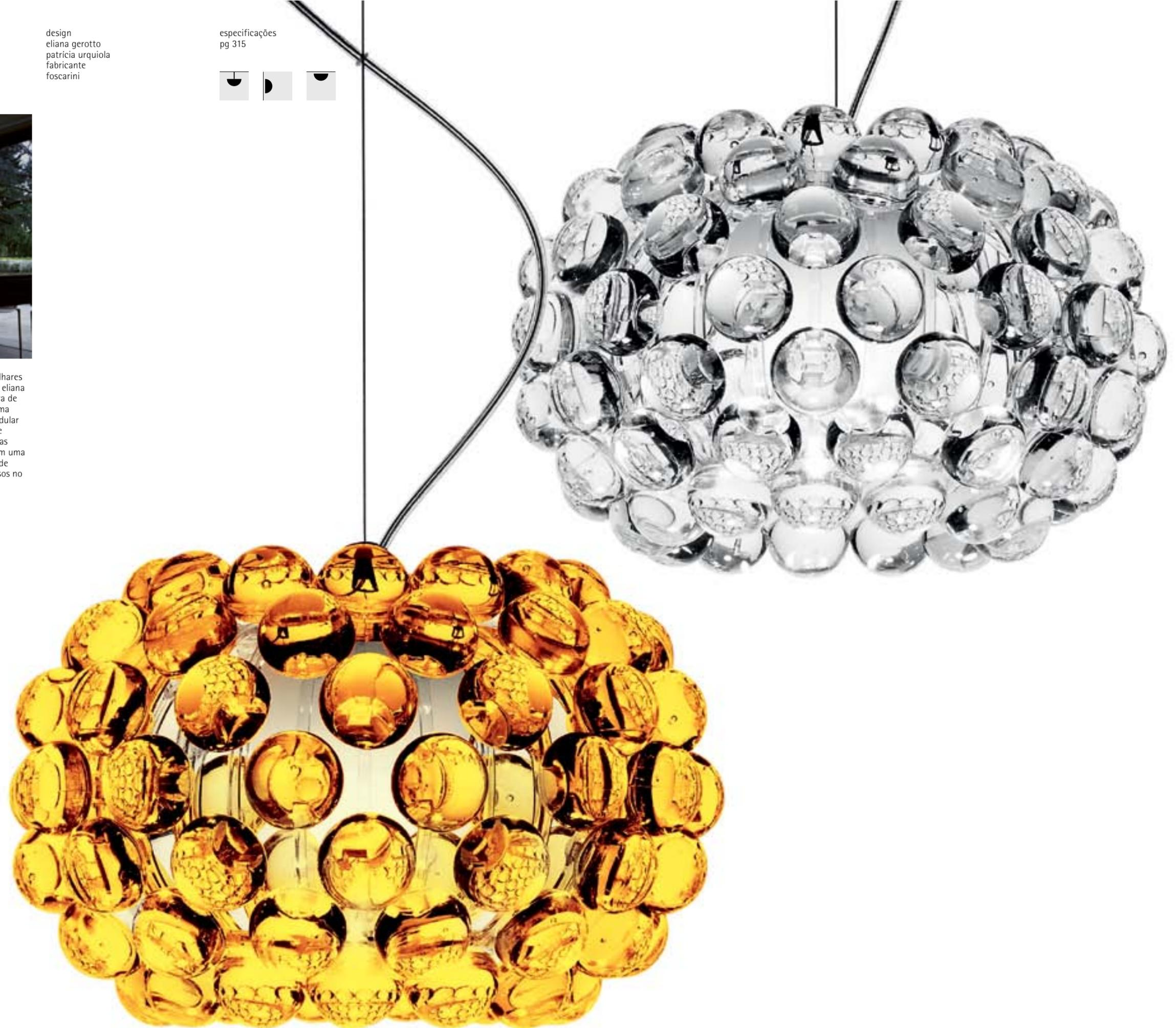



cage



design
diesel
fabricante
foscarini

inspirada nos ambientes subterrâneos, cage faz referência aos objetos de iluminação utilizados pelos trabalhadores dentro das minas. as típicas lâmpadas protegidas por jaulas de metal foram transformadas em elementos decorativos por meio de um trabalho artesanal evidenciado por estruturas irregulares

especificações
pg 317



chouchin

design
ionna vautrin
fabricante
foscarini

especificações
pg 319



chouchin foi inspirada nas típicas lanternas japonesas de papel e bambu. formas tradicionais transformadas pela designer ionna vautrin em peças contemporâneas e surpreendentes. produzidas em vidro soprado - um material milenar - estas luminárias possuem um acabamento que as torna completamente impermeáveis à luz interior e brilhantes pelo lado de fora. o resultado é uma iluminação direta e quente. seus três modelos podem ser usadas em composição ou individualmente



copper shade

design
tom dixon
fabricante
tom dixon

especificações
pg 320



copper propõe novas leituras ao cobre, um material crucial para o desenvolvimento tecnológico, normalmente associado às células solares e à radiação de microondas. estas luminárias com ângulos arredondados e linhas marcantes exploram a flexibilidade e o dinamismo da matéria-prima, proporcionando sofisticação a qualquer tipo de ambiente. seu acabamento metálico altamente reflexivo é resultado da explosão de uma fina camada de metal sobre a superfície interna de um globo de policarbonato

costanza

design
paolo rizzatto
fabricante
luceplan

especificações
pg 321



costanza é uma das mais conhecidas linhas de luminárias do designer italiano paolo rizzatto. a primeira versão foi desenvolvida em 1986 e, desde então, não deixou de ser produzida. seu design tradicional com toques contemporâneos faz com que seja apropriada para qualquer tipo de ambiente

costanzina

design
paolo rizzatto
fabricante
luceplan

especificações
pg 323



costanzina é uma extensão da linha de luminárias costanza, uma das mais conhecidas criações do designer italiano paolo rizzatto. sua primeira versão foi desenvolvida em 1986 e, desde então, não deixou de ser produzida. em costanzina, os difusores ficam menores, aumentando as possibilidades de utilização. o mesmo conceito e a mesma tecnologia, com novas dimensões



etch se destaca não só pela sua figura imponente, mas também pela forma como é produzida. manufaturada digitalmente, esta luminária pendente possui uma superfície de metal delicadamente recortada por meio de um processo industrial usado na fabricação de componentes eletrônicos. quando acesa, cria um interessante efeito de sombras; resultado da interação entre os feixes de luz e as estampas vazadas

fork

design
diesel
fabricante
foscarini

especificações
pg 328

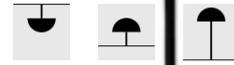

a inspiração da luminária fork vem da vida informal, dinâmica, despojada. sua estética rústica faz referência ao jeans e às barracas de camping. a luz interna realça a estrutura de patchwork e a textura do tecido. graças a um difusor flexível e a uma haste articulada, é possível brincar com a luminária e direcionar o foco de luz

glas

design
diesel
fabricante
foscarini

especificações
pg 331



glas apresenta uma releitura das típicas luminárias industriais utilizadas em armazéns e fábricas de todo o mundo. um ícone transformado pelo design contemporâneo em uma peça autêntica e com dupla função: quando está apagada, seu acabamento cromado reflete o ambiente ao redor; quando acesa, emite uma luz quente, com toque vintage



glassglass

design
paolo rizzatto
fabricante
luceplan

especificações
pg 332



composta por uma haste de metal e um difusor em vidro soprado, glassglass é uma luminária versátil, que pode ser usada como pendente ou arandela. oferece dois tamanhos de pendural e uma vasta gama de difusores com diferentes formatos e acabamentos. uma peça clássica e marcante, adaptável a qualquer estilo de decoração



gregg

design
ludovica
roberto palomba
fabricante
foscarini

especificações
pg 333



uma massa incandescente transformada pelo sopro em uma forma orgânica e geométrica. os designers ludovica e roberto palomba converteram o vidro em um objeto que chama a atenção por seu volume puro. versátil e original, gregg difunde uma luminosidade suave e uniforme no ambiente



havana

design
joseph forakis
fabricante
foscarini



havana surpreende não só por seu inusitado formato, que lembra um charuto cubano, mas também pelo material do qual é composto: polietileno. leve e versátil, esta luminária oferece uma luz pura e simples, pensada para iluminar áreas específicas nos ambientes. pode ser usada como arandela ou pendente



especificações
pg 336

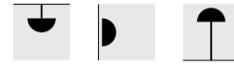

hope

design
francisco gomez paz
paolo rizzato
fabricante
luceplan

especificações
pg 337



para criar hope, os designers francisco gomez paz e paolo rizzato uniram a magia das luminárias tradicionais e a sofisticação dos materiais contemporâneos. composta por uma série de finas lentes de polícarbonato de fresnel, esta peça multiplica os raios de luz, criando uma agradável atmosfera repleta de efeitos luminosos





joy surpreende pela originalidade dos materiais. feitas em polipropileno translúcido, as pétalas serigrafadas dos difusores proporcionam uma iluminação difusa e agradável. disponível nas versões pendente e piso, esta luminária se adapta a qualquer tipo de ambiente



le soleil

design
vicente garcia jimenez
fabricante
foscarini

especificações
pg 342



uma ideia simples inspirada nas manhãs. a partir de uma reflexão sobre como percebemos a luz do sol, o designer vicente garcia jimenez concebeu a luminária le soleil. trata-se de uma esfera composta por arcos irregulares, que proporciona uma agradável iluminação, combinando luz direta e indireta. com três opções de cor, le soleil oferece personalidade e estilo ao ambiente



lightweight



design
tom dixon
fabricante
foscarini

especificações
pg 343



lightweight foi desenvolvida por tom dixon para a foscarini em 1995. seu nome deve-se ao fato da peça ser extremamente leve, apesar de suas grandes dimensões. composto por uma estrutura geométrica em metal anodizado e elementos em vidro acetinado branco, este imponente pendente mistura os estilos clássico e futurista

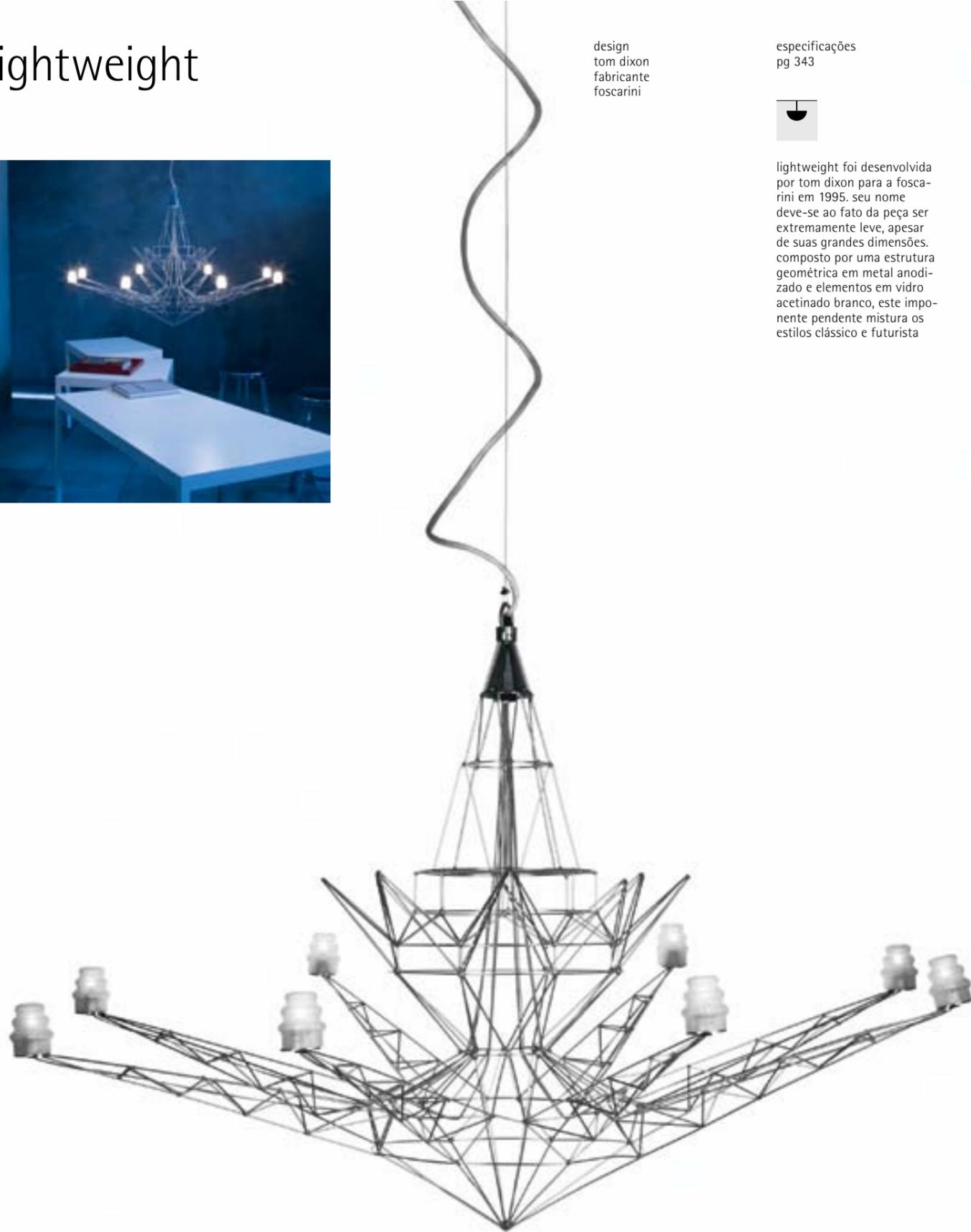

maki



design
nendo
fabricante
foscarini

especificações
pg 346



maki nasce de uma inspiração natural, espontânea: duas folhas metálicas delicadamente enroladas para dar vida a uma flor. poética e intrigante, esta luminária explora a imaterialidade da luz para criar uma sensação suave e relaxante no ambiente, oferecendo um duplo efeito luminoso. disponível na versão pendente, maki pode ser usada individualmente ou em composição



mirror ball

design
tom dixon
fabricante
tom dixon

especificações
pg 346



inspirada nos capacetes espaciais, mirror ball foi criada a partir da explosão de uma fina camada de metal na superfície interna de um globo de policarbonato, gerando um efeito espelhado. disponível em diferentes tamanhos - nas versões pendente e piso - , mirror ball se transformou em um ícone da marca tom dixon

o-space

design
giampietro gai
luca nichetto
fabricante
foscarini

especificações
pg 351



com um formato ao mesmo tempo suave e geométrico, original e intrigante, o-space permite inúmeras interpretações. feito em poliuretano, o pendente é formado por uma esfera achatada e recortada nos dois lados, permitindo uma iluminação refletida no interior da peça e direcionada para baixo. uma forma que se adapta a qualquer estilo de decoração





piccolo

design
fernando prado
fabricante
lumini

especificações
pg 352



simplicidade e versatilidade são características marcantes nas luminárias assinadas por fernando prado. em piccolo, o designer faz uma releitura descontraída e delicada dos tradicionais abajures. com cúpula em vidro opalino soprado e base em alumínio usinado, esta luminária oferece uma iluminação indireta, suave e agradável



pipe light

design
tom dixon
fabricante
tom dixon

especificações
pg 354



pipe pode ser definida como uma escultura luminosa tubular feita em alumínio extrudado. com uma silhueta fina e elegante, esta luminária se destaca no ambiente graças ao contraste de acabamentos e cores de suas superfícies. versátil, emite uma luz concentrada que muda de direção de acordo com a posição do difusor



planet

design
changedesign
fabricante
foscarini



especificações
pg 355



planet partiu da ideia de se criar uma luminária de tecido totalmente oca. esta elegante peça é resultado da combinação entre design e tecnologia: uma superfície rigorosamente branca desenhada com um fio especial que, quando submetido a altas temperaturas, se transforma em um suporte rígido e resistente

plissé

design
inga sempé
fabricante
luceplan

especificações
pg 356

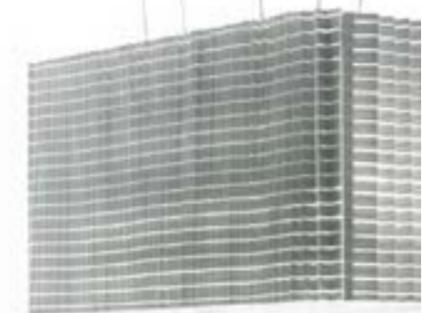
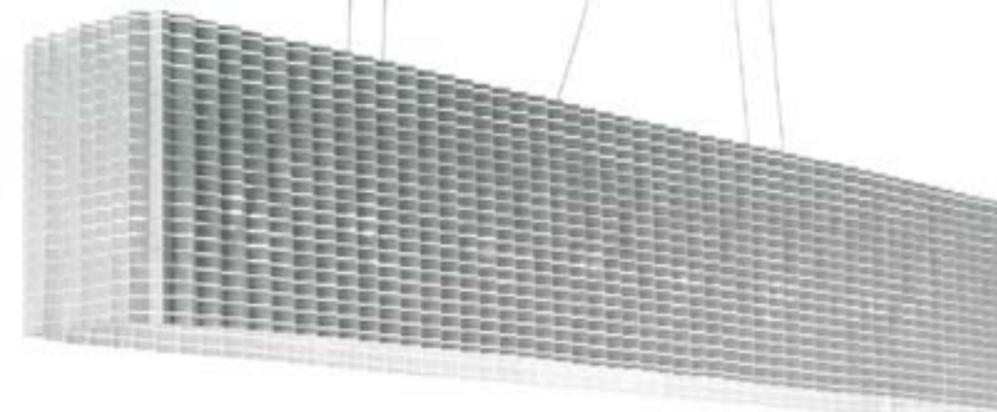

em plissé, a designer inga sempé oferece uma interpretação moderna da antiga arte das pregas, usada em vários setores da indústria para criar volume e dar forma a materiais planos. esta luminária é resultado da combinação de dois elementos contrastantes: o rígido metal de sua estrutura e o suave tecido de seu difusor. com um simples gesto, plissé muda de tamanho, variando de 60 a 160 cm de largura. projetada para mesas e estações de trabalho, oferece uma iluminação uniforme e grande adaptabilidade

quadratta

design
fernando prado
fabricante
lumini

especificações
pg 356



quadratta chama a atenção pelo equilíbrio e as proporções de seus componentes: uma base composta por duas chapas de alumínio suspensas por cabos eletrificados. esta luminária pendente oferece uma suave iluminação indireta e se adequa a diversos tipos de ambientes



rock

design
diesel
fabricante
foscarini

especificações
pg 356



inspirada nas rochas vulcânicas, rock propõe um jogo de contrastes. sua estrutura assimétrica e seu acabamento interno reflexivo criam um efeito visual surpreendente no ambiente. rock oferece opções de aplicação e acabamento



secto

design
seppo koho
fabricante
secto design

especificações
pg 357



assinadas pelo arquiteto finlandês seppo koho, as luminárias secto chamam a atenção pela simplicidade de seu design. com proporções perfeitas e acabamento impecável, elas são esculpidas à mão em madeira de bétula por artesãos altamente qualificados. o cuidado com os detalhes é visível também no projeto técnico. as tiras que compõem a cúpula, por exemplo, servem tanto para proteger a lâmpada como para direcionar o fecho de luz

theodora

design
fernando prado
fabricante
lumini

especificações
pg 358



em theodora, o designer fernando prado utilizou vidros com diferentes tratamentos e texturas para criar interessantes luminárias pendentes. peças marcantes, ideais para iluminar pontos específicos no ambiente, como mesas de jantar ou bancadas de trabalho

tite

design
marc sadler
fabricante
foscarini

especificações
pg 348



tite é resultado de mais de dois anos de estudo e pesquisa. uma linha original desenvolvida a partir de uma mistura de fibra de vidro e fio de carbono nunca antes utilizada para produzir luminárias. com uma estética quase étnica, esta peça se adapta perfeitamente a qualquer ambiente, oferecendo uma iluminação de ótima qualidade, com uma presença discreta e elegante

tool

design
diesel
fabricante
foscarini

especificações
pg 359



tool foi inspirada na atmosfera vintage das oficinas e fábricas. com um formato que lembra os moldes de fundição, esta luminária surpreende pela sua leveza. feita em borracha, com estética e design inovadores, tool está disponível em dois tamanhos



tress

design
marc sadler
fabricante
foscarini

especificações
pg 360



a sedução das tranças femininas serviu de inspiração para o desenvolvimento das luminárias tress. fibras de vidro e resina entrelaçadas com uma ordenada casualidade se transformam em estruturas originais. uma ousada combinação entre design e tecnologia que resultou na criação de peças únicas. seus toques gráficos, fortes e persuasivos lembram objetos artesanais





twiggy

design
marc sadler
fabricante
foscarini

especificações
pg 362



para criar twiggy, o designer marc sadler tomou como ponto de partida um objeto aparentemente simples e despretenso: uma vara de pescar. linear e longilíneo, este objeto foi transformado em uma luminária leve e flexível, que se adapta a qualquer tipo de ambiente. com linhas amplas e ângulos sofisticados, esta peça garante uma elegância formal e moderna



uto

design
lagranja design
fabricante
foscarini

especificações
pg 363

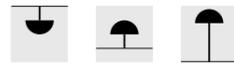

a ideia dos designers gabriele schiavon e gerard sanmartí nasceu da vontade de criar luminárias compostas por formas únicas, flexíveis e divertidas. a dupla utilizou borracha de silicone, um material nunca antes usado na iluminação, para desenvolver uto, uma peça contemporânea, lúdica e maleável, que pode ser usada com aplicação pendente, de piso ou de mesa, tanto em ambientes internos como externos

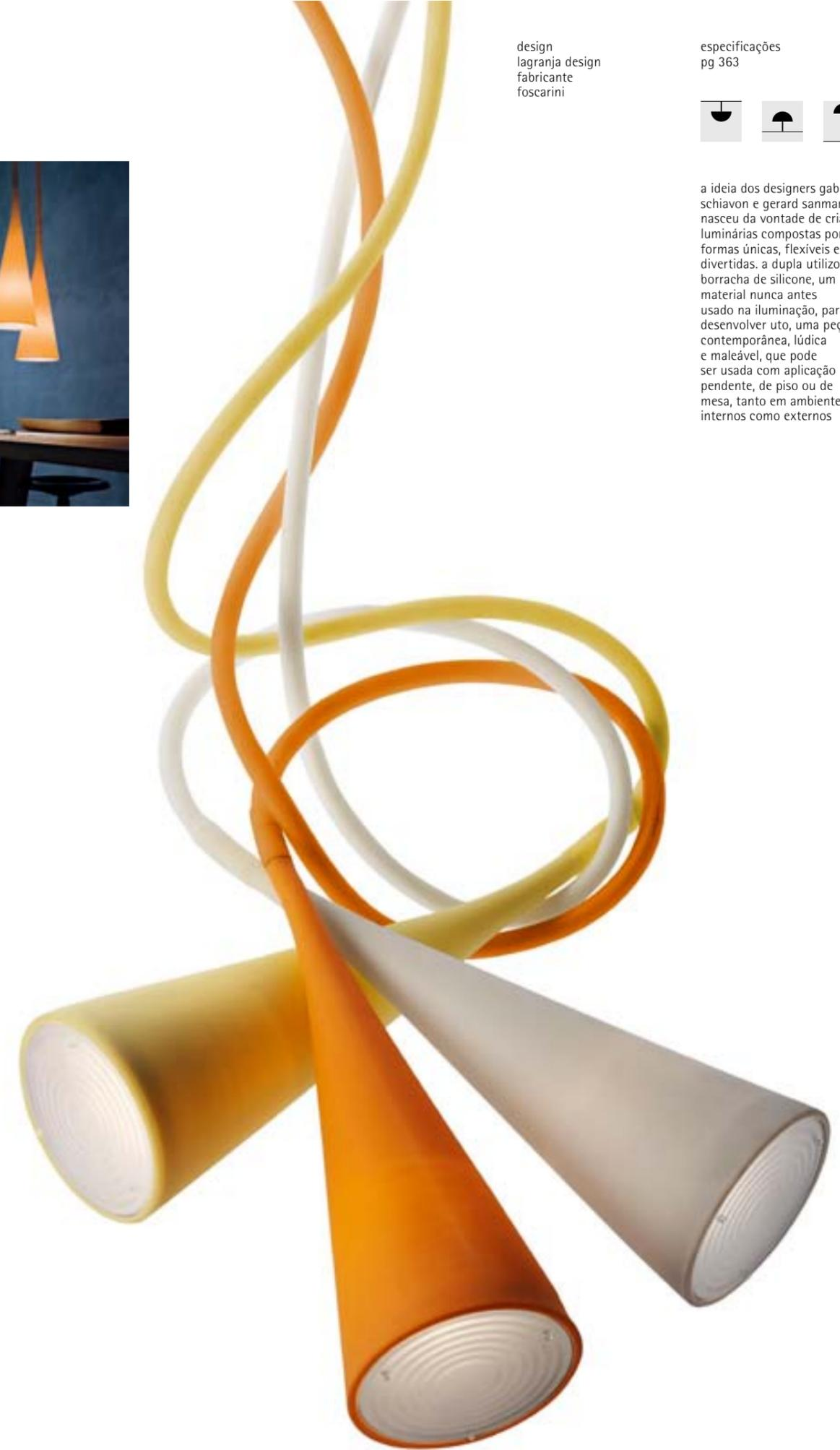



prêmios
good design
2012
mcb
2012

vinte2 foi criada por fernando prado em comemoração aos 90 anos da semana de arte moderna. as referências ao movimento modernista podem ser percebidas em diferentes elementos que compõem a peça: do contraste entre madeira e alumínio ao sistema de acionamento artesanal, todos os detalhes de vinte2 estabelecem um diálogo entre o passado e o presente





void light



design
tom dixon
fabricante
tom dixon

especificações
pg 364



inspirada nas medalhas olímpicas, void é produzida a partir de folhas de metal prensadas e moldadas. esta misteriosa peça possui uma superfície espelhada altamente brilhante, por ser polida manualmente e, em seguida, laqueada. design e técnica impecáveis, unidos para criar uma luminária imponente e original



wave

design
studio baruffi & de santi
fabricante
foscarini

especificações
pg 365



wave surge como uma nova ideia para iluminar e decorar o espaço. uma peça criativa que pode ser usada de diferentes formas, com total liberdade. sua silhueta sinuosa fornece estilo a um elemento técnico, sugerindo uma sensação de flexibilidade e suavidade. produzida em alumínio laqueado, ela possui uma luz difusa e agradável

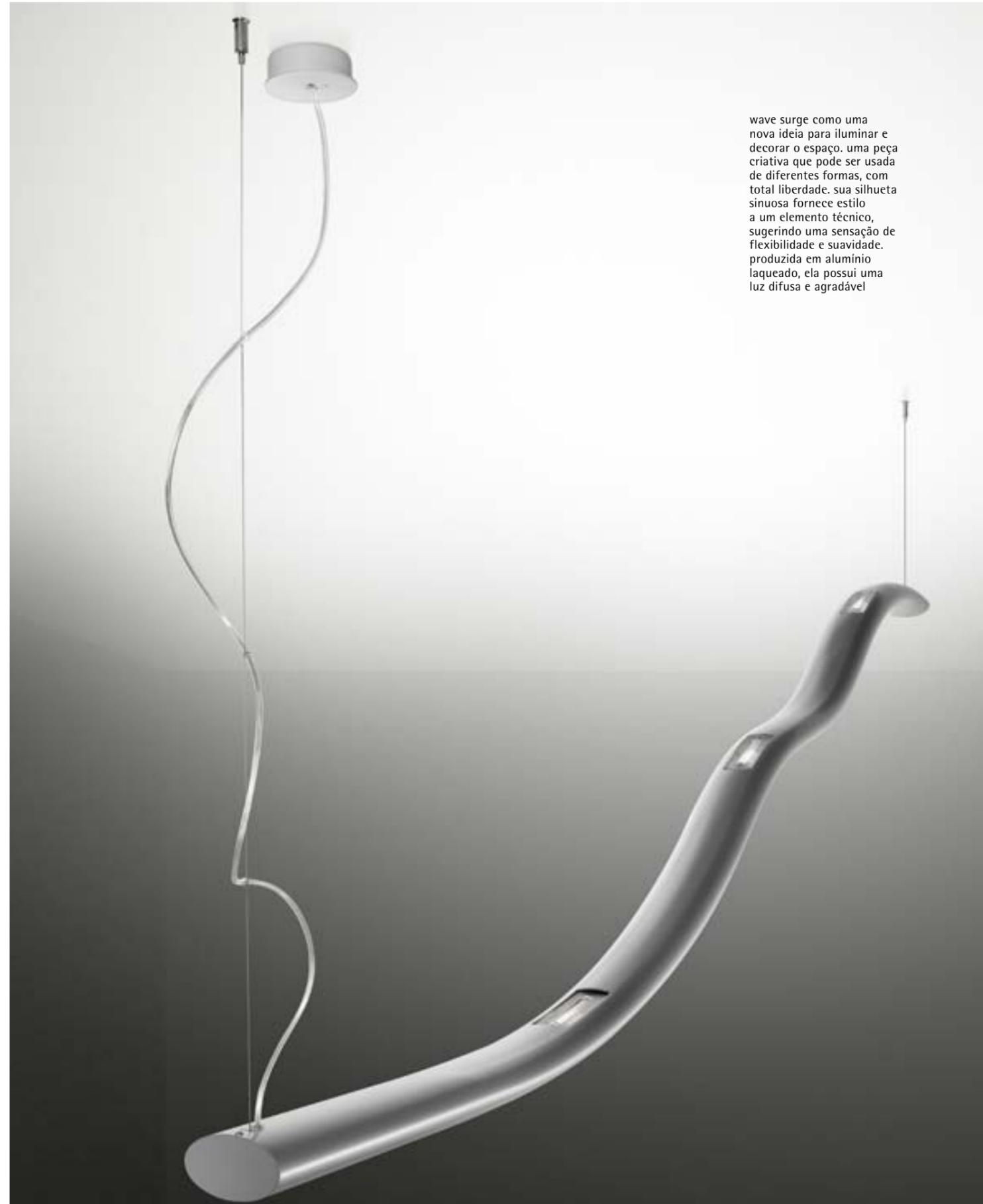



wish

design
fernando prado
fabricante
lumini

especificações
pg 365

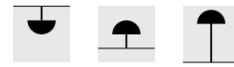

a luminária wish é um exemplo de funcionalidade e praticidade. produzida em alumínio e tecido, oferece uma estética limpa e minimalista

arandelas





base

design
tom dixon
fabricante
tom dixon

especificações
pg 299

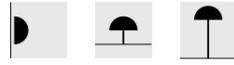

desenvolvida a partir de uma original combinação de metais, base é composta por difusores em bronze com acabamento acetinado e hastes em metal fundido com textura fosca. um projeto que remete às origens da carreira de tom dixon e à sua paixão pela metalurgia

bocci 14

design
omar arbel
fabricante
bocci

especificações
pg 310



desenhada por omar arbel em 2005, esta luminária desafia o conceito original dos lustres, normalmente utilizados como peças centrais de um ambiente. 14 abandona a ideia do protagonismo escultural e aposta em uma estratégia de composição e volume para preencher o espaço. ela emite interessantes efeitos luminosos que resultam da interação entre a luz e as esferas de vidro fundido



caboche

design
eliana gerotto
patricia urquiola
fabricante
foscarini

especificações
pg 315

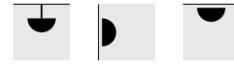

caboche surgiu dos olhares de patricia urquiola e eliana gerotto a uma pulseira de pérolas. a partir de uma estrutura de arco modular e pequenas esferas de polimetilmetacrilato, as designers conseguiram uma luz pura que se difunde como cristais luminosos no ambiente



costanzina

design
paolo rizzatto
fabricante
luceplan

especificações
pg 323



costanzina é uma extensão da linha de luminárias costanza, uma das mais conhecidas criações do designer italiano paolo rizzatto. sua primeira versão foi desenvolvida em 1986 e, desde então, não deixou de ser produzida. em costanzina, os difusores ficam menores, aumentando as possibilidades de utilização. o mesmo conceito e a mesma tecnologia, com novas dimensões



inspirada na natureza,
esta arandela foi dese-
nhada para recriar o efeito
luminoso de um eclipse.
simples e sofisticada,
funciona como um inte-
ressante objeto decorativo
ao mesmo tempo em que
oferece uma luz suave e
agradável



gregg

design
ludovica
roberto palomba
fabricante
foscarini

especificações
pg 333



uma massa incandescente transformada pelo sopro em uma forma orgânica e geométrica. os designers ludovica e roberto palomba converteram o vidro em um objeto que chama a atenção por seu volume puro. versátil e original, gregg difunde uma luminosidade suave e uniforme no ambiente

havana

design
joseph forakis
fabricante
foscarini

especificações
pg 336



havana surpreende não só por seu inusitado formato, que lembra um charuto cubano, mas também pelo material do qual é composto: polietileno. leve e versátil, esta luminária oferece uma luz pura e simples, pensada para iluminar áreas específicas nos ambientes. pode ser usada como arandela ou pendente



hope

design
francisco gomez paz
paolo rizzatto
fabricante
luceplan

especificações
pg 337



para criar hope, os designers francisco gomez paz e paolo rizzatto uniram a magia das luminárias tradicionais à sofisticação dos materiais contemporâneos. composta por uma série de finas lentes de policarbonato de fresnel, esta peça multiplica os raios de luz, criando uma agradável atmosfera repleta de efeitos luminosos



kite

design
marc sadler
fabricante
foscarini

especificações
pg 348



mite é resultado de mais de dois anos de estudo e pesquisa. uma linha original desenvolvida a partir de uma mistura de fibra de vidro e fio de carbono nunca antes utilizada para produzir luminárias. com uma estética quase étnica, esta peça se adapta perfeitamente a qualquer ambiente, oferecendo uma iluminação de ótima qualidade, com uma presença discreta e elegante, disponível em diferentes aplicações e modelos



metropoli

design
alberto meda
paolo rizzato
ricardo sarfatti
fabricante
luceplan

especificações
pg 346



metropoli é uma peça simples e elementar. uma luminária de estilo clássico, com estrutura em alumínio fundido e difusor em vidro ou policarbonato impermeável. pode ser usada como arandela ou aplicada ao teto, tanto em ambientes internos como externos, adaptando-se facilmente a qualquer tipo de decoração. graças a seu design contemporâneo e inteligente sistema de funcionamento, foi contemplada com o prêmio compasso d'oro, em 1994



piccolo

design
fernando prado
fabricante
lumini

especificações
pg 352



simplicidade e versatilidade são características marcantes nas luminárias assinadas por fernando prado. em piccolo, o designer faz uma releitura descontraída e delicada dos tradicionais abajures. com cúpula em vidro opalino soprado e base em alumínio usinado, esta arandela oferece uma iluminação indireta, suave e agradável

trama

design
luciano balestrini
paola longhi
fabricante
luceplan

especificações
pg 359



trama foi desenvolvida pelos designers luciano balestrini e paola longhi em 1986 como uma opção discreta e elegante de iluminação ambiente. por meio de seu difusor de policarbonato, a luz é difundida uniformemente, criando uma atmosfera leve e agradável. versátil, esta peça pode ser usada como arandela ou aplicada ao teto

tress

design
marc sadler
fabricante
foscarini

especificações
pg 360

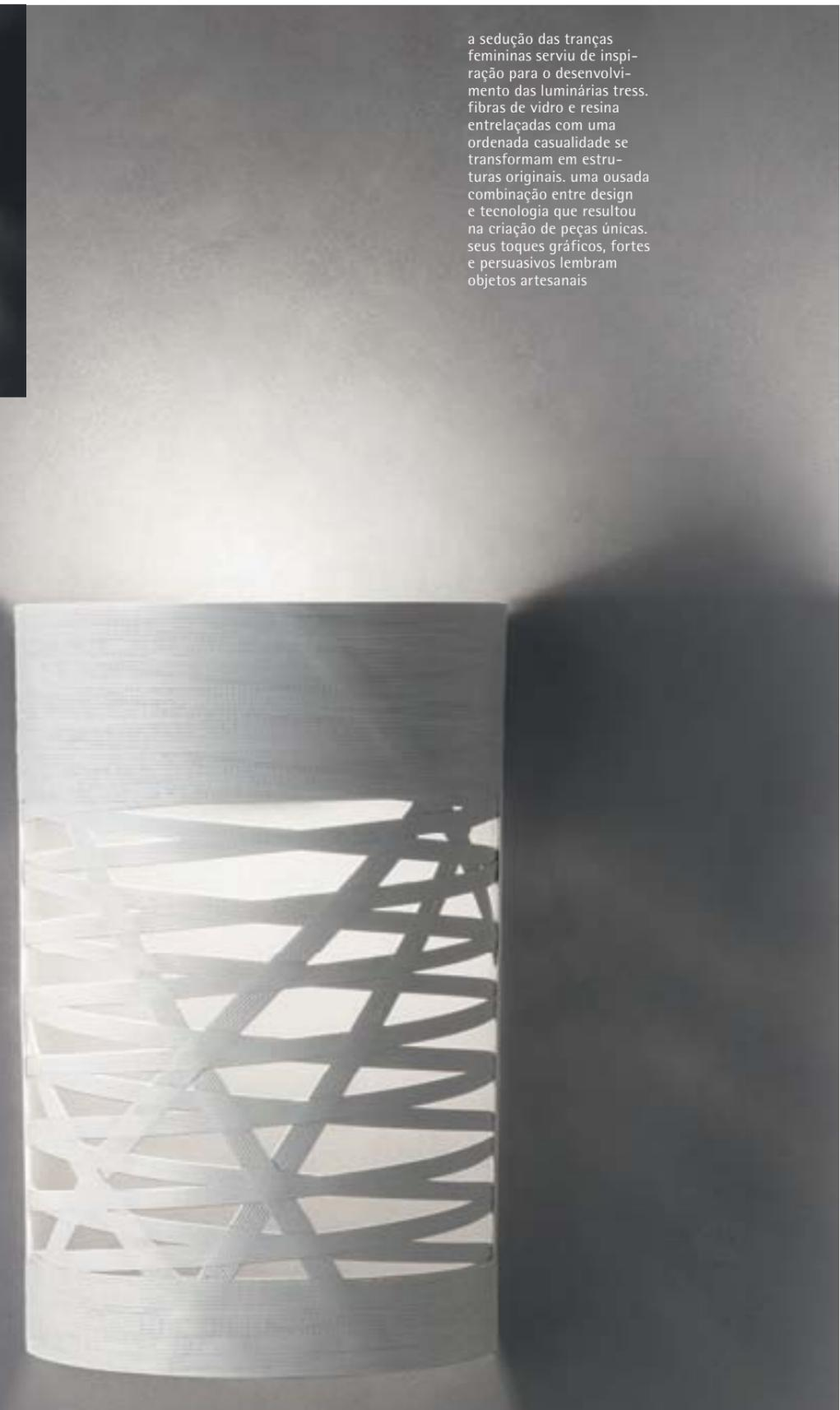

a sedução das tranças femininas serviu de inspiração para o desenvolvimento das luminárias tress. fibras de vidro e resina entrelaçadas com uma ordenada casualidade se transformam em estruturas originais. uma ousada combinação entre design e tecnologia que resultou na criação de peças únicas. seus toques gráficos, fortes e persuasivos lembram objetos artesanais



bauhaus 90

design
fernando prado
fabricante
lumini

especificações
pg 304

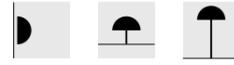

desenhada em comemoração aos 90 anos da bauhaus, esta luminária tem forte influência da escola alemã. com linguagem própria e contemporânea, bauhaus 90 possui um inteligente sistema de regulação de altura, que dispensa o uso de travas ou parafusos. seu difusor orientável permite direcionar o fecho de luz, obtendo diferentes efeitos de iluminação



prêmios
german design
2012
if
2011
red dot
2011
good design
2010
idea brasil
2010
mcb
2010

berenice

design
alberto meda
paolo rizzatto
fabricante
luceplan

especificações
pg 307



criada por alberto meda e paolo rizzatto em 1985, berenice é sinônimo de praticidade. com um design contemporâneo, marcado por longos braços articulados e refletores arredondados, a peça oferece uma iluminação concentrada e direta, que pode ser facilmente orientada pelo usuário



duii

design
diesel
fabricante
diesel

especificações
pg 324



um jogo de montar, um personagem dos quadrinhos, um pequeno robô doméstico. duii surpreende e diverte por suas originais características, começando pelo nome, inspirado em um dos sobrinhos do pato donald. isto porque sua base – que também pode ser usada como porta-objetos – lembra um pé de pato. um flexível braço articulado unido por parafusos em forma de borboleta sustenta o difusor

fortebraccio

design
alberto meda
paolo rizzatto
fabricante
luceplan

especificações
pg 329

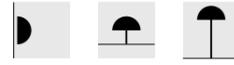

inspirada na liberdade,
esta luminária articulada é
sinônimo de versatilidade.
sua estrutura oferece uma
solução inteligente para
o direcionamento do foco
de luz: como um cotovelo,
a articulação especial
dos braços proporciona
movimentos leves e fluidos

glassglass

design
paolo rizzatto
fabricante
luceplan

especificações
pg 332



composta por uma haste de
metal e um difusor em vidro
soprado, glassglass é uma
luminária versátil, que pode
ser usada como pendente
ou arandela. oferece dois
tamanhos de pendural e uma
vasta gama de difusores com
diferentes formatos e acaba-
mentos. uma peça clássica e
marcante, adaptável a qual-
quer estilo de decoração

jieldé signal

design
jean-louis domecq
fabricante
jieldé

especificações
pg 340

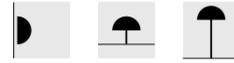

as luminárias signal são uma extensão de loft – peça que deu origem à marca jieldé há mais de 60 anos. versáteis, práticas e resistentes são consideradas um ícone da arte industrial francesa. produzidas em lyon com técnicas tradicionais e materiais resistentes, estas luminárias são numeradas, o que faz com que cada uma seja única

led it be

design
fernando prado
fabricante
lumini

especificações
pg 342



prêmios
german design
2010
if
2009
mcb
2008

uma luminária com forte identidade conceitual e visual, pensada para atender às necessidades do usuário. como o próprio nome sugere, led it be se deixa levar. graças a uma haste flexível e orientável, seu fecho de luz pode ser direcionado para leitura. utiliza tecnologia LED, garantindo uma luz eficiente, com baixo consumo e sem emissão de calor



aplicadas

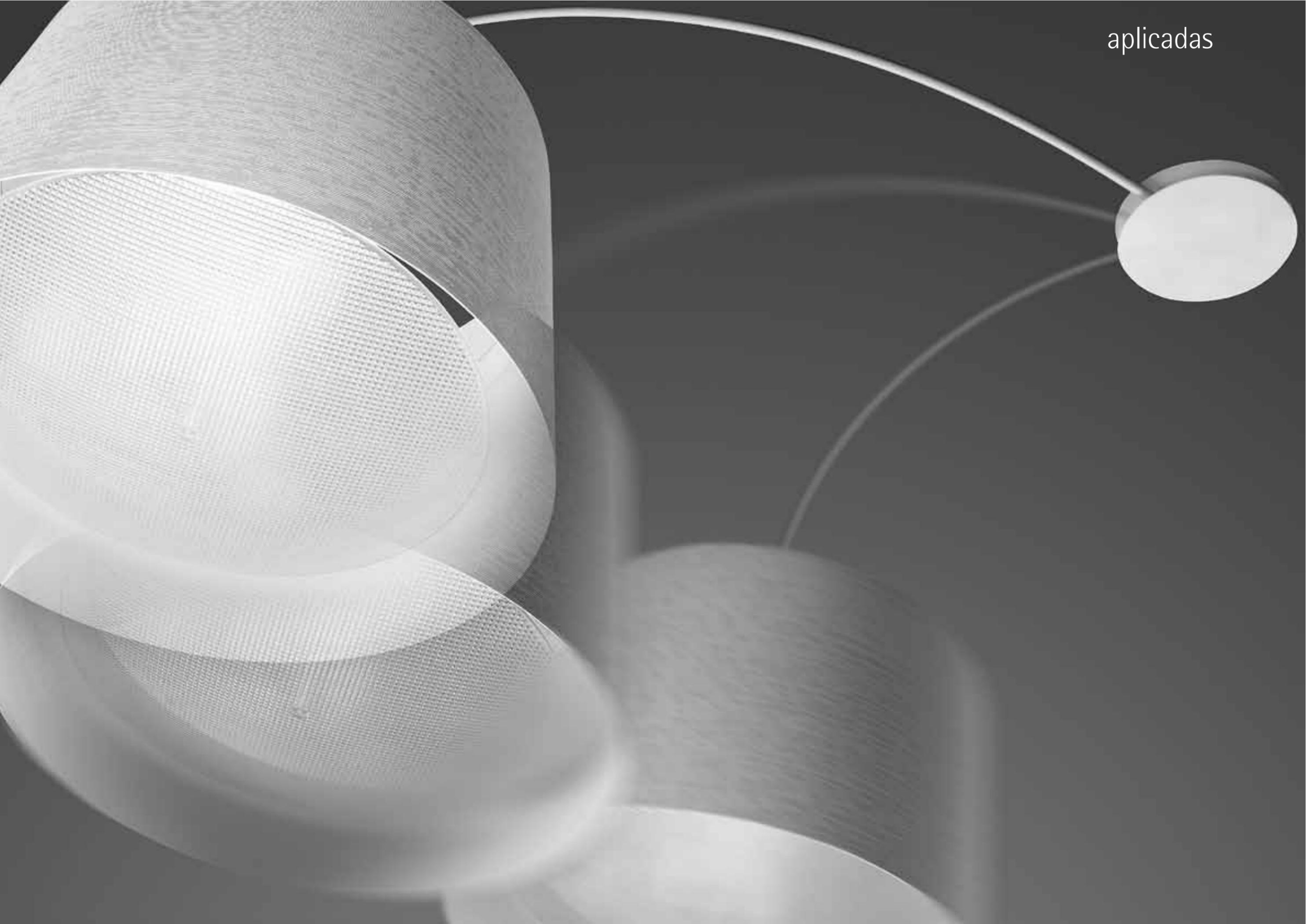

blow

design
ferdi giardini
fabricante
luceplan

especificações
pg 313

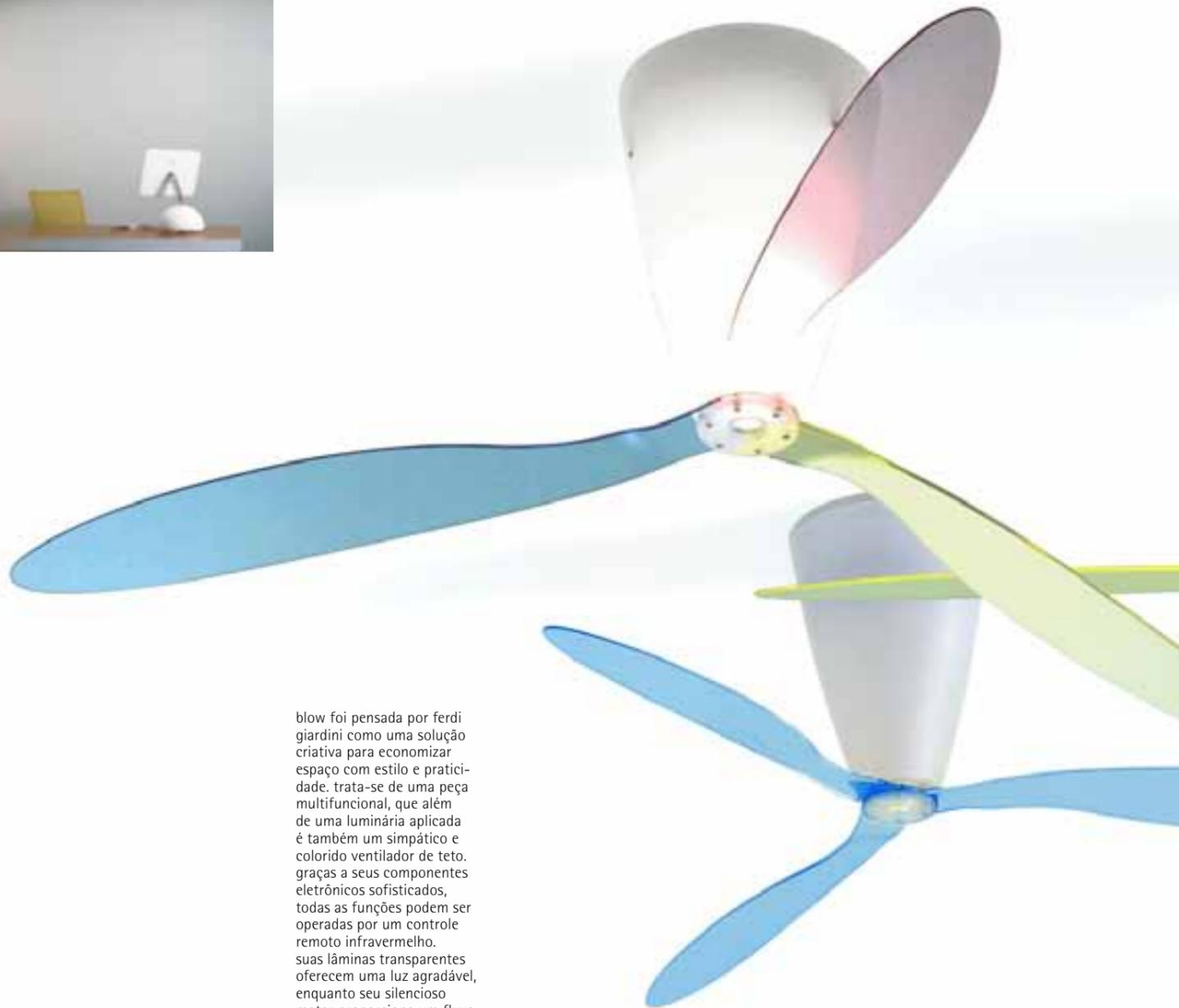

blow foi pensada por ferdi giardini como uma solução criativa para economizar espaço com estilo e praticidade. trata-se de uma peça multifuncional, que além de uma luminária aplicada é também um simpático e colorido ventilador de teto. graças a seus componentes eletrônicos sofisticados, todas as funções podem ser operadas por um controle remoto infravermelho. suas lâminas transparentes oferecem uma luz agradável, enquanto seu silencioso motor proporciona um fluxo contínuo de ar

bocci 14

design
omar arbel
fabricante
bocci

especificações
pg 310



desenhada por omar arbel em 2005, esta luminária desafia o conceito original dos lustres, normalmente utilizados como peças centrais de um ambiente. 14 abandona a ideia do protagonismo escultural e aposta em uma estratégia de composição e volume para preencher o espaço. ela emite interessantes efeitos luminosos que resultam da interação entre a luz e as esferas de vidro fundido

caboche

design
eliana gerotto
patricia urquiola
fabricante
foscarini

especificações
pg 315

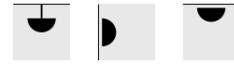

caboche surgiu dos olhares de patricia urquiola e eliana gerotto a uma pulseira de pérolas. a partir de uma estrutura de arco modular e pequenas esferas de polimetilmetacrilato, as designers conseguiram uma luz pura que se difunde como cristais luminosos no ambiente

gregg

design
ludovica
roberto palomba
fabricante
foscarini

especificações
pg 333



uma massa incandescente transformada pelo sopro em uma forma orgânica e geométrica. os designers ludovica e roberto palomba converteram o vidro em um objeto que chama a atenção por seu volume puro, versátil e original, gregg difunde uma luminosidade suave e uniforme no ambiente

luna

design
fernando prado
fabricante
lumini

especificações
pg 345



luna é um dos projetos mais conceituais do designer fernando prado. sua proposta é estabelecer uma relação direta com as fases da lua: por meio de um anteparo orientável, reproduz efeitos luminosos similares às luas nova, crescente, quarto crescente e cheia. em 2005, luna representou a criatividade do design brasileiro em um selo dos correios

prêmios
german design
2007
top XXI
2007
red dot
2006
good design
2005
if gold
2005
mcb
2004

metropoli

design
alberto meda
paolo rizzato
ricardo sarfatti
fabricante
luceplan

especificações
pg 346



metropoli é uma peça simples e elementar. uma luminária de estilo clássico, com estrutura em alumínio fundido e difusor em vidro ou policarbonato impermeável. pode ser usada como arandela ou aplicada ao teto, tanto em ambientes internos como externos, adaptando-se facilmente a qualquer tipo de decoração. graças a seu design contemporâneo e inteligente sistema de funcionamento, foi contemplada com o prêmio compasso d'oro, em 1994



trama

design
luciano balestrini
paola longhi
fabricante
luceplan

especificações
pg 359



trama foi desenvolvida pelos designers luciano balestrini e paola longhi em 1986 como uma opção discreta e elegante de iluminação ambiente. por meio de seu difusor de policarbonato, a luz é difundida uniformemente, criando uma atmosfera leve e agradável. versátil, esta peça pode ser usada como arandela ou aplicada ao teto

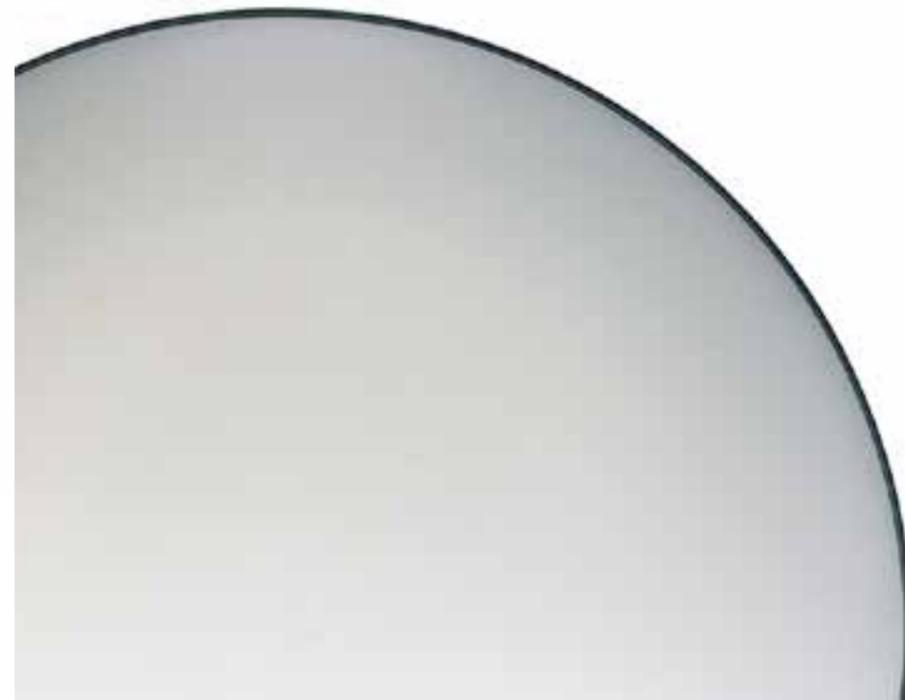

twiggy

design
marc sadler
fabricante
foscarini

especificações
pg 362



para criar twiggy, o designer marc sadler tomou como ponto de partida um objeto aparentemente simples e despretenso: uma vara de pescar. linear e longilíneo, este objeto foi transformado em uma luminária leve e flexível, que se adapta a qualquer tipo de ambiente. com linhas amplas e ângulos sofisticados, esta peça garante uma elegância formal e moderna

mesa





anisha

design
lievore altherr molina
fabricante
foscarini

especificações
pg 298



como uma moldura, anisha limita, define e preenche o espaço com sua luz. uma forma plástica e dinâmica que realça os ambientes com seu duplo papel de luminária e escultura. para manter o equilíbrio estético da peça, os designers optaram pelo uso da tecnologia LED, cujo volume é praticamente imperceptível



atollo

design
vico magistretti
fabricante
oluce

especificações
pg 299



atollo é um projeto de design internacionalmente conhecido, presente nas coleções permanentes de alguns dos mais importantes museus do mundo. o segredo desta peça, desenvolvida por vico magistretti em 1977, está na geometria das formas: cone, cilindro e semi-esfera harmoniosamente equilibrados como uma escultura luminosa

baju

design
fernando prado
fabricante
lumini

especificações
pg 299



o designer fernando prado propõe para baju uma releitura sofisticada dos tradicionais abajures de mesa. com cúpula em tecido cru e haste em madeira, baju oferece uma iluminação difusa, adequada a diversos tipos de ambientes

base

design
tom dixon
fabricante
tom dixon

especificações
pg 299



desenvolvida a partir de uma original combinação de metais, base é composta por um difusor em bronze com acabamento acetinado e uma haste em metal fundido com textura fosca. um projeto que remete às origens da carreira de tom dixon e à sua paixão pela metalurgia



a natureza foi a fonte de inspiração do designer werner aisslinger para a criação de beehive. esta luminária de mesa lembra a forma de uma colmeia. seu volume é resultado da sobreposição de anéis com diâmetros que aumentam progressivamente a partir da base. graças à especial inclinação destes anéis, a fonte luminosa fica escondida, criando um efeito suave e único



binic

design
ionna vautrin
fabricante
foscarini

especificações
pg 309



binic é o nome de um farol na costa da bretanha, região de origem da designer ionna vautrin. ela se inspirou nas birutas dos barcos para criar esta pequena e colorida luminária de mesa. cheia de personalidade, a peça chama a atenção por sua forma poética e inusitada. com uma arquitetura simples e surpreendente - volume superior arredondado e base cônica - binic parece desafiar a força da gravidade





birdie

design
ludovica
roberto palomba
fabricante
foscarini

especificações
pg 309



inspirada no formato das árvores, birdie possui um design fino e estilizado, com uma haste que lembra um tronco e um difusor que remete às clássicas luminárias de leitura. seu original sistema de acendimento tem o formato de um pequeno ramo, pronto para acolher um passarinho



cage

design
diesel
fabricante
foscarini

especificações
pg 317



inspirada nos ambientes subterrâneos, cage faz referência aos objetos de iluminação utilizados pelos trabalhadores dentro das minas. as típicas lâmpadas protegidas por jaulas de metal foram transformadas em elementos decorativos por meio de um trabalho artesanal evidenciado por estruturas irregulares



costanza

design
paolo rizzatto
fabricante
luceplan

especificações
pg 321



costanza é uma das mais conhecidas linhas de luminárias do designer italiano paolo rizzatto. a primeira versão foi desenvolvida em 1986 e, desde então, não deixou de ser produzida. seu design tradicional com toques contemporâneos faz com que seja apropriada para qualquer tipo de ambiente



costanzina

design
paolo rizzato
fabricante
luceplan

especificações
pg 323

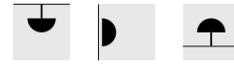

costanzina é uma extensão da linha de luminárias costanza, uma das mais conhecidas criações do designer italiano paolo rizzato. sua primeira versão foi desenvolvida em 1986 e, desde então, não deixou de ser produzida. em costanzina, os difusores ficam menores, aumentando as possibilidades de utilização. o mesmo conceito e a mesma tecnologia, com novas dimensões



esa 07

design
lievore altherr molina
fabricante
foscarini

especificações
pg 326



esta luminária de mesa desenvolvida pelo estúdio espanhol lievore altherr molina é ideal para caracterizar pontos específicos da casa ou do escritório. elegante e funcional, esa 07 agrega personalidade à mesa de trabalho ou ao móvel de apoio. seu difusor em vidro atua como filtro, proporcionando uma agradável iluminação do ambiente



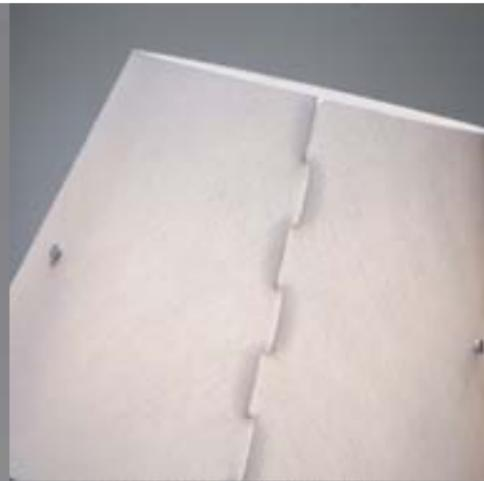

fernando prado se inspirou no balanço do boneco joão bobo para criar fool. lúdica, ela convida o usuário a brincar com suas posições, direcione o fecho de luz e se divirta com seu movimento de pêndulo. ao mesmo tempo, funciona perfeitamente como um abajur. com cúpula em feltro e base em aço e aço inox, fool está disponível em dois tamanhos e seis combinações de cor



prêmio
idea brasil
2013



fork

design
diesel
fabricante
foscarini

especificações
pg 328

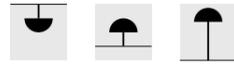

a inspiração da luminária fork vem da vida informal, dinâmica, despojada. sua estética rústica faz referência ao jeans e às barracas de camping. a luz interna realça a estrutura de patchwork e a textura do tecido. graças a um difusor flexível e a uma haste articulada, é possível brincar com a luminária e direcionar o foco de luz



glas

design
diesel
fabricante
foscarini

especificações
pg 331



glas apresenta uma releitura das típicas luminárias industriais utilizadas em armazéns e fábricas de todo o mundo. um ícone transformado pelo design contemporâneo em uma peça autêntica e com dupla função: quando está apagada, seu acabamento cromado reflete o ambiente ao redor; quando acesa, emite uma luz quente, com toque vintage



gregg

design
ludovica
roberto palomba
fabricante
foscarini



especificações
pg 333



uma massa incandescente transformada pelo sopro em uma forma orgânica e geométrica. os designers ludovica e roberto palomba converteram o vidro em um objeto que chama a atenção por seu volume puro. versátil e original, gregg difunde uma luminosidade suave e uniforme no ambiente



lite

design
marc sadler
fabricante
foscarini

especificações
pg 348



lite é resultado de mais de dois anos de estudo e pesquisa. uma peça original desenvolvida a partir de uma mistura de fibra de vidro e fio de carbono nunca antes utilizada para produzir luminárias. com uma estética quase étnica, ela se adapta perfeitamente a qualquer ambiente, oferecendo uma iluminação de ótima qualidade, com uma presença discreta e elegante



lumiere 05

design
rodolfo dordoni
fabricante
foscarini

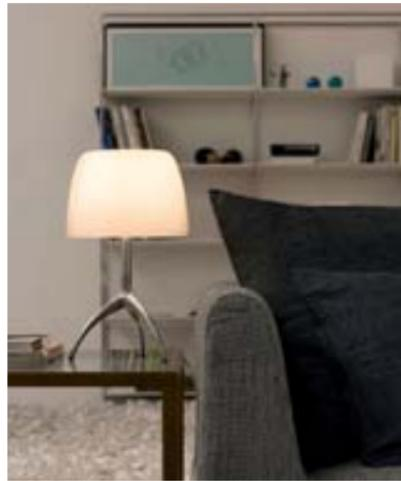

especificações
pg 343



para desenvolver esta luminária, o designer rodolfo dordoni propôs uma releitura elegante e criativa dos tradicionais abajures. em lumiere 05, os extremos conversam: memória e atualidade, artesanato e tecnologia, calor e frio. disponíveis em quatro opções de cor, estas peças se adequam com perfeição a ambientes contemporâneos

lumiere xx



em lumiere XX, o conceito de contraste da lumiere 05 é mantido, mas as formas adquirem outros ângulos: as hastes, assim como os difusores, abandonam o formato arredondado e adotam um aspecto mais marcante. novas geometrias definem uma personalidade forte e uma elegância refinada



ovalle

design
fernando prado
fabricante
lumini

especificações
pg 351



simplicidade e versatilidade são características marcantes nos projetos assinados por fernando prado. em ovalle, o designer apostou nos ângulos arredondados para criar luminárias com um estilo sofisticado e discreto. feitas em aço inox e vidro opalino, estas peças se adaptam a qualquer tipo de ambiente

piccolo

design
fernando prado
fabricante
lumini

especificações
pg 352

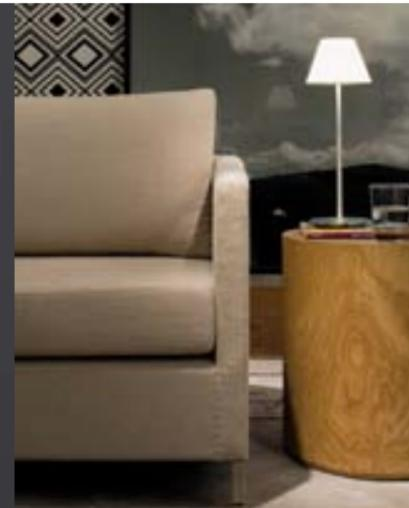

em piccolo, o designer fernando prado faz uma releitura descontraída e delicada dos tradicionais abajures. com cúpula em vidro opalino e base em alumínio, esta luminária de mesa se destaca pela simplicidade e versatilidade

piccolo R

design
fernando prado
fabricante
lumini

especificações
pg 352



com o objetivo de colorir a linha piccolo, fernando prado criou a simpática piccoloR. esta luminária de mesa é produzida em alumínio com pintura eletrostática e está disponível em diversas cores





pipe

design
diesel
fabricante
foscarini

especificações
pg 354



o design de pipe, inspirado nas tubulações industriais, vai ao encontro da linguagem fashion da diesel. a textura irregular do linho bruto transforma pipe em totens luminosos, revolucionando a idéia das tradicionais luminárias de tecido. estas peças podem ser usadas individualmente ou em composição para iluminar, caracterizar e definir espaços de diferentes estilos



secto

design
seppo koho
fabricante
secto design

especificações
pg 357



assinadas pelo arquiteto finlandês seppo koho, as luminárias secto chamam a atenção pela simplicidade de seu design. com proporções perfeitas e acabamento impecável, elas são esculpidas à mão em madeira de bétula por artesãos altamente qualificados. o cuidado com os detalhes é visível também no projeto técnico. as tiras que compõem a cúpula, por exemplo, servem tanto para proteger a lâmpada como para direcionar o fecho de luz



tua

design
marco zito
fabricante
foscarini

especificações
pg 362



tua foi inspirada na palma de uma mão que irradia luz. um simples gesto expresso por uma fonte luminosa escondida em uma plataforma metálica. uma peça discreta que, quando acesa, transmite uma agradável sensação de intimidade e toma conta de pequenos pontos do ambiente – do criado-mudo à mesa de trabalho



vinte2

design
fernando prado
fabricante
lumini

especificações
pg 364



vinte2 foi criada por fernando prado em comemoração aos 90 anos da semana de arte moderna. as referências ao movimento modernista podem ser percebidas em diferentes elementos que compõem a peça: do contraste entre madeira e alumínio ao sistema de acionamento artesanal, todos os detalhes de vinte2 estabelecem um diálogo entre o passado e o presente

prêmios
good design
2012
mcb
2012





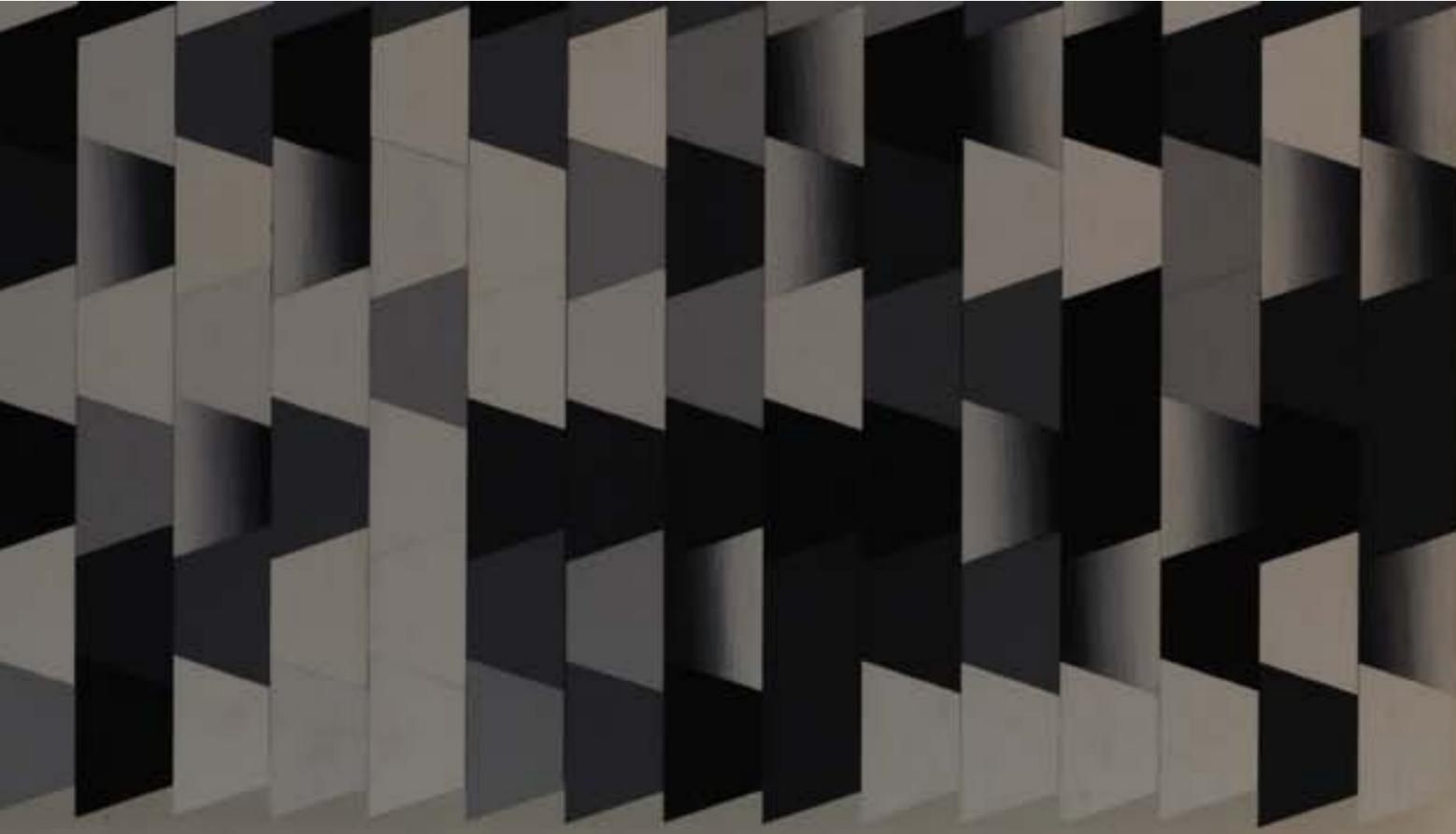

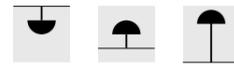

a luminária wish é um exemplo de funcionalidade e praticidade. produzida em alumínio e tecido, ela foi pensada para ocupar o mínimo de espaço com sua base, possibilitando assim um melhor aproveitamento do mobiliário







bauhaus 90

design
fernando prado
fabricante
lumini

especificações
pg 304

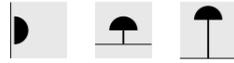

prêmios
german design
2012
if
2011
red dot
2011
good design
2010
idea brasil
2010
mcb
2010

desenhada em comemoração aos 90 anos da bauhaus, esta luminária tem forte influência da escola alemã. com linguagem própria e contemporânea, bauhaus 90 possui um inteligente sistema de regulação de altura, que dispensa o uso de travas ou parafusos. seu difusor orientável permite direcionar o fecho de luz, obtendo diferentes efeitos de iluminação





berenice

design
alberto meda
paolo rizzatto
fabricante
luceplan

especificações
pg 307

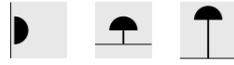

criada por alberto meda e paolo rizzatto em 1985, berenice é sinônimo de praticidade. com um design contemporâneo, marcado por longos braços articulados e refletores arredondados, as peças oferecem uma iluminação concentrada e direta, que pode ser facilmente orientada pelo usuário. além de sua versão tradicional, berenice está disponível ainda para tecnologia LED nas cores preta e alumínio

bill

design
tobias grau
fabricante
tobias grau

especificações
pg 308



bill é uma luminária de mesa clássica e versátil. possui braços articulados e um dispositivo de fixação de fácil ajuste. por meio de uma alça, permite movimentar e posicionar o foco de luz em qualquer ponto da mesa. com uma estética limpa e formal, adapta-se naturalmente às necessidades do usuário

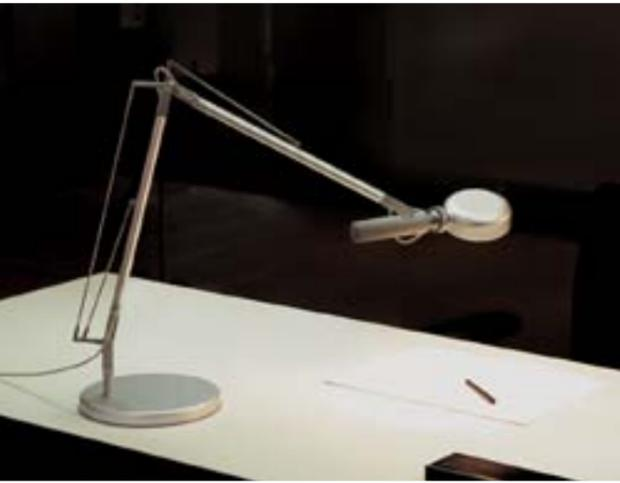

duii

design
diesel
fabricante
diesel

especificações
pg 324



um jogo de montar, um personagem dos quadrinhos, um pequeno robô doméstico. duii surpreende e diverte por suas originais características, começando pelo nome, inspirado em um dos sobrinhos do pato donald. isto porque sua base - que também pode ser usada como porta-objetos - lembra um pé de pato. um flexível braço articulado unido por parafusos em forma de borboleta sustenta o difusor

fortebraccio

design
alberto meda
paolo rizzatto
fabricante
luceplan

especificações
pg 329

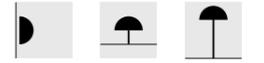

inspirada na liberdade, esta luminária articulada é sinônimo de versatilidade. sua estrutura oferece uma solução inteligente para o direcionamento do foco de luz: como um cotovelo, a articulação especial dos braços proporciona movimentos leves e fluidos. Fortebraccio é feita em policarbonato e é ideal para iluminar mesas de trabalho



ginga

design
fabio falanghe
fabricante
lumini

especificações
pg 330



inspirada no swing brasileiro, ginga possui um sistema de articulação que permite um giro de 360° em sua haste, facilitando o direcionamento do foco de luz. contemplada, em 2011, com o mais antigo prêmio de design internacional do mundo, o good design, ginga é feita em alumínio e está disponível em diversas cores

prêmios
german design
2013
good design
2011



jieldé loft

design
jean-louis domeneq
fabricante
jieldé

especificações
pg 338



a primeira luminária loft foi criada por jean-louis domeneq em 1950 para atender às necessidades específicas de seu ofício como mecânico. uma peça robusta e articulada; adaptável a diferentes ambientes de trabalho. batizada de standard, a luminária fez tanto sucesso que, em 1953, domeneq criou a marca jieldé com o propósito de comercializá-la. na década de 1990, a luminária passou a se chamar loft. ainda hoje, seu processo de fabricação se mantém quase inalterado: as peças são produzidas de forma artesanal e numeradas individualmente

jieldé signal

design
jean-louis domeneq
fabricante
jieldé

especificações
pg 340

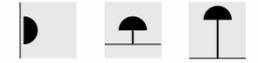

as luminárias signal são uma extensão de loft – peça que deu origem à marca jieldé há mais de 60 anos. versáteis, práticas e resistentes são consideradas um ícone da arte industrial francesa. produzidas em lyon com técnicas tradicionais e materiais resistentes, estas luminárias são numeradas, o que faz com que cada uma seja única



uma luminária com forte identidade conceitual e visual, pensada para atender às necessidades do usuário. como o próprio nome sugere, led it be se deixa levar. graças a uma haste flexível e orientável, seu fecho de luz pode ser direcionado para leitura. utiliza tecnologia LED, garantindo uma luz eficiente, com baixo consumo e sem emissão de calor

pett

design
diesel
fabricante
foscarini

especificações
pg 351



pett pode ser definida como a expressão da cultura pop contemporânea. feita em policarbonato e metal, esta luminária de mesa com difusor regulável oferece uma luz concentrada, ideal para ambientes despojados



pixell

design
fabio falanghe
fabricante
lumini

especificações
pg 355



para a dupla de designers giorgio giorgi e fabio falanghe eficiência é um importante critério a ser considerado para se desenvolver um projeto de iluminação. pensando nisso, criaram pixell, uma luminária de mesa orientável, que utiliza LED para oferecer uma iluminação com baixo consumo e sem emissão de calor





twiggy

design
marc sadler
fabricante
foscarini

especificações
pg 362



para criar twiggy, o designer marc sadler tomou como ponto de partida um objeto aparentemente simples e desprezível: uma vara de pescar. linear e longilíneo, este objeto foi transformado em uma luminária leve e flexível, que se adapta a qualquer tipo de ambiente. com linhas amplas e ângulos sofisticados, esta peça garante uma elegância formal e moderna

piso



base

design
tom dixon
fabricante
tom dixon

especificações
pg 299

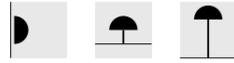

desenvolvida a partir de uma original combinação de metais, base é composta por um difusor em bronze com acabamento acetinado e uma haste em metal fundido com textura fosca. um projeto que remete às origens da carreira de tom dixon e à sua paixão pela metalurgia

bauhaus 90

design
fernando prado
fabricante
lumini

especificações
pg 304

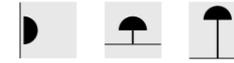

prêmios
german design
2012
if
2011
red dot
2011
good design
2010
idea brasil
2010
mcb
2010



desenhada em comemoração aos 90 anos da bauhaus, esta luminária tem forte influência da escola alemã. com linguagem própria e contemporânea, bauhaus 90 possui um inteligente sistema de regulagem de altura, que dispensa o uso de travas ou parafusos. seu difusor orientável permite direcionar o fecho de luz, obtendo diferentes efeitos de iluminação





berenice

design
alberto meda
paolo rizzatto
fabricante
luceplan

especificações
pg 307

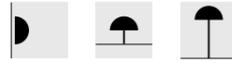

criada por alberto meda e paolo rizzatto em 1985, berenice é sinônimo de praticidade. com um design contemporâneo, marcado por longos braços articulados e refletores arredondados, a peça oferece uma iluminação concentrada e direta, que pode ser facilmente orientada pelo usuário

birdie

design
ludovica
roberto palomba
fabricante
foscarini

especificações
pg 309



inspirada no formato das árvores, birdie possui um design fino e estilizado, com uma haste que lembra um tronco e um difusor que remete às clássicas luminárias de leitura. seu original sistema de acendimento tem o formato de um pequeno ramo, pronto para acolher um passarinho



bridge

design
fernando prado
fabricante
lumini

especificações
pg 314



versatilidade e interação com o usuário são os pontos fortes de bridge. produzida em aço inox e feltro, esta luminária articulada possui sistema de travamento por mola que permite orientar o feixe de luz em diferentes posições e alturas. seu design simples e funcional é perfeito para qualquer tipo de ambiente

cage

design
diesel
fabricante
foscarini

especificações
pg 317



inspirada nos ambientes subterrâneos, cage faz referência aos objetos de iluminação utilizados pelos trabalhadores dentro das minas. as típicas lâmpadas protegidas por jaulas de metal foram transformadas em elementos decorativos por meio de um trabalho artesanal evidenciado por estruturas irregulares

carrara

design
alfredo häberli
fabricante
luceplan

especificações
pg 318



um bloco único de poliuretano transformado por alfredo häberli em uma escultura luminosa. neutra e elegante, carrara oferece uma luz indireta e agradável. sua silhueta discreta, porém com personalidade, adapta-se perfeitamente a ambientes com diferentes estilos de decoração. está disponível nas cores branca e preta

costanza

design
paolo rizzatto
fabricante
luceplan

especificações
pg 321

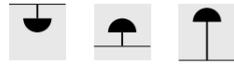

costanza é uma das mais conhecidas linhas de luminárias do designer italiano paolo rizzatto. a primeira versão foi desenvolvida em 1986 e, desde então, não deixou de ser produzida. seu design tradicional com toques contemporâneos faz com que seja apropriada para qualquer tipo de ambiente. disponível em diferentes tamanhos e modelos

fat spot

design
tom dixon
fabricante
tom dixon

especificações
pg 320



dinâmica e versátil, fat spot pode ser usada tanto no piso quanto na mesa. produzida em cobre e policarbonato, esta peça foi inspirada nos projetores para iluminação de teatros. sua base e seu difusor são ajustáveis, permitindo direcionar o fecho de luz conforme desejado



fina

design
fernando prado
fabricante
lumini

especificações
pg 327



para desenvolver fina, o maior desafio enfrentado pelo designer fernando prado foi a estruturação do produto, já que a base é ligada ao corpo da luminária através de uma haste finíssima em aço inox escovado. um desenho simples e discreto e um sistema de orientação do facho permitem uma iluminação indireta adequada a diferentes espaços

prêmios
german design
2012
if
2011
idea brasil
2010

fork

design
diesel
fabricante
foscarini

especificações
pg 328



a inspiração da luminária fork vem da vida informal, dinâmica, despojada. sua estética rústica faz referência ao jeans e às barracas de camping. a luz interna realça a estrutura de patchwork e a textura do tecido. graças a um difusor flexível e a uma haste articulada, é possível brincar com a luminária e direcionar o foco de luz



fortebraccio

design
alberto meda
paolo rizzato
fabricante
luceplan

especificações
pg 329

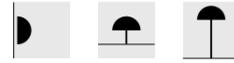

inspirada na liberdade, esta luminária articulada é sinônimo de versatilidade. sua estrutura oferece uma solução inteligente para o direcionamento do foco de luz: como um cotovelo, a articulação especial dos braços proporciona movimentos leves e fluidos

giga lite

design
marc sadler
fabricante
foscarini

especificações
pg 348



giga lite é resultado de mais de dois anos de estudo e pesquisa. uma linha original desenvolvida a partir de uma mistura de fibra de vidro e fio de carbono nunca antes utilizada para produzir luminárias. com uma estética quase étnica, esta peça se adapta perfeitamente a qualquer ambiente, oferecendo uma iluminação de ótima qualidade, com uma presença discreta e elegante. disponível em diferentes aplicações e modelos

gregg

design
ludovica
roberto palomba
fabricante
foscarini

especificações
pg 333



uma massa incandescente transformada pelo sopro em uma forma orgânica e geométrica. os designers ludovica e roberto palomba converteram o vidro em um objeto que chama a atenção por seu volume puro. versátil e original, gregg difunde uma luminosidade suave e uniforme no ambiente

havana

design
joseph forakis
fabricante
foscarini

especificações
pg 336



havana surpreende não só pelo seu inusitado formato, que lembra um charuto cubano, mas também pelo material do qual é composto: polietileno. leve e versátil, esta luminária oferece uma luz pura e simples, pensada para iluminar áreas específicas nos ambientes





jieldé loft

design
jean-louis domeneq
fabricante
jieldé

especificações
pg 338



a primeira luminária loft foi criada por jean-louis domeneq em 1950 para atender às necessidades específicas de seu ofício como mecânico. uma peça robusta e articulada; adaptável a diferentes ambientes de trabalho. batizada de standard, a luminária fez tanto sucesso que, em 1953, domeneq criou a marca jieldé com o propósito de comercializá-la. na década de 1990, a luminária passou a se chamar loft. ainda hoje, seu processo de fabricação se mantém quase inalterado: as peças são produzidas de forma artesanal e numeradas individualmente



jieldé signal

design
jean-louis domeneq
fabricante
jieldé

especificações
pg 340



as luminárias signal são uma extensão de loft – peça que deu origem à marca jieldé há mais de 60 anos. versáteis, práticas e resistentes são consideradas um ícone da arte industrial francesa. produzidas em lyon com técnicas tradicionais e materiais resistentes, estas luminárias são numeradas, o que faz com que cada uma seja única



joy surpreende pela originalidade dos materiais. feitas em polipropileno translúcido, as pétalas serigrafadas dos difusores proporcionam uma iluminação difusa e agradável. disponível nas versões pendente e piso, esta luminária se adapta a qualquer tipo de ambiente



lift nasceu da ideia de criar uma luminária de piso com uma fixação inusitada, sem as habituais bases estruturais de grande dimensão. o resultado é uma inovadora haste de inox de seção oval que se apoia na parede e permite o livre movimento da cúpula, aumentando sua gama de aplicações. assim como várias outras peças de fernando prado, lift é conhecida e admirada pela interação que propõe ao usuário

prêmios
german design
2011
if
2010
brazil design
2009
good design
2009
idea brasil
2009
mcb
2009





prêmios
german design
2007
top XXI
2007
red dot
2006
good design
2005
if gold
2005
mcb
2004



luna é um dos projetos mais conceituais do designer fernando prado. sua proposta é estabelecer uma relação direta com as fases da lua: por meio de um anteparo orientável, reproduz efeitos luminosos similares às luas nova, crescente, quarto crescente e cheia. em 2005, luna representou a criatividade do design brasileiro em um selo dos correios

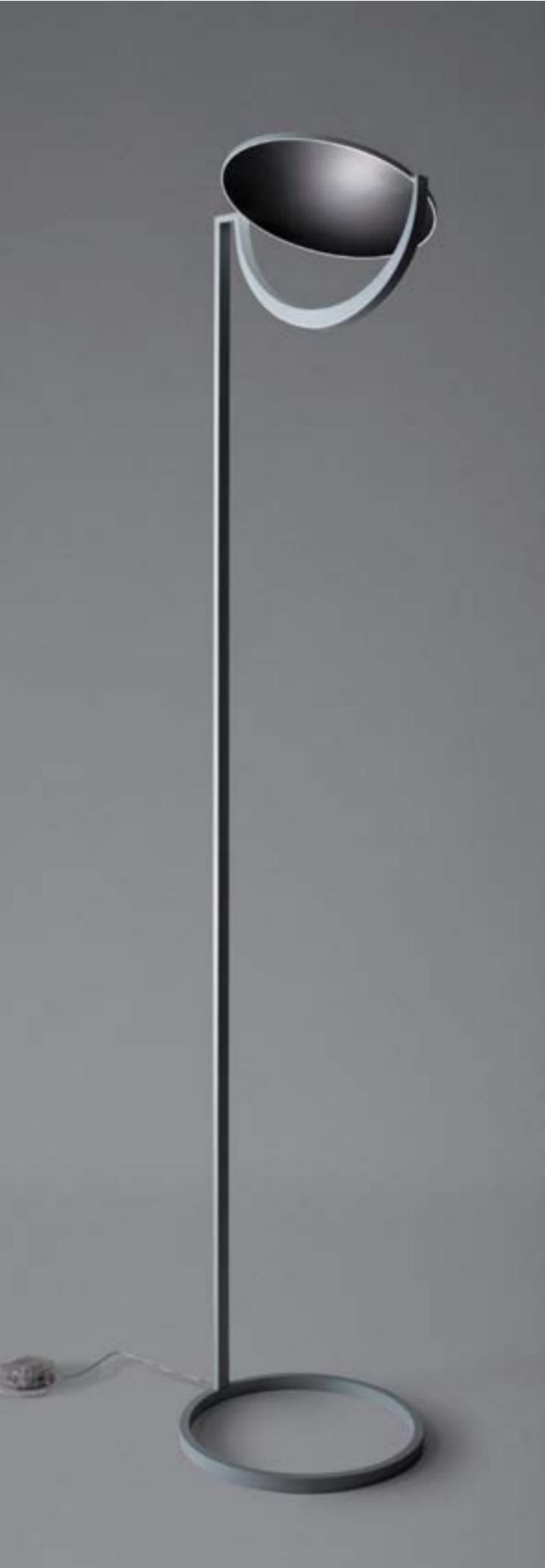

magneto

design
giulio iacchetti
fabricante
foscarini



o designer giulio iacchetti combinou estética, funcionalidade e tecnologia para desenvolver magneto, uma luminária extremamente versátil, que oferece inúmeras possibilidades de utilização. o segredo é um ímã esférico que une dois elementos: uma haste de apoio equipada com uma base circular e uma estrutura luminosa de LED que se assemelha a um microfone. com um foco de luz intenso e concentrado, magneto é perfeita tanto para iluminação ambiente como para leitura



especificações
pg 345



mirror ball

design
tom dixon
fabricante
tom dixon

especificações
pg 346



inspirada nos capacetes espaciais, mirror ball foi criada a partir da explosão de uma fina camada de metal na superfície interna de um globo de policarbonato, gerando um efeito espelhado. disponível em diferentes tamanhos - nas versões pendente e piso -, mirror ball se transformou em um ícone da marca tom dixon



mite

design
marc sadler
fabricante
foscarini

especificações
pg 348



mite é resultado de mais de dois anos de estudo e pesquisa. uma linha original desenvolvida a partir de uma mistura de fibra de vidro e fio de carbono nunca antes utilizada para produzir luminárias. com uma estética quase étnica, esta peça se adapta perfeitamente a qualquer ambiente, oferecendo uma iluminação de ótima qualidade, com uma presença discreta e elegante. disponível em diferentes aplicações e modelos



piccolo

design
fernando prado
fabricante
lumini

especificações
pg 352



simplicidade e versatilidade são características marcantes nas luminárias assinadas por fernando prado. em piccolo, o designer faz uma releitura descontraída e delicada dos tradicionais abajures. com cúpula em vidro opalino soprado e base em alumínio usinado, esta luminária oferece uma iluminação indireta, suave e agradável



pipe

design
diesel
fabricante
foscarini

especificações
pg 354



o design de pipe, inspirado nas tubulações industriais, vai ao encontro da linguagem fashion da diesel. a textura irregular do linho bruto transforma pipe em totens luminosos, revolucionando a ideia das tradicionais luminárias de tecido. estas peças podem ser usadas individualmente ou em composição para iluminar, caracterizar e definir espaços de diferentes estilos



rock

design
diesel
fabricante
foscarini

especificações
pg 356



solar outdoor

design
jean marie massaud
fabricante
foscarini

especificações
pg 358



inspirada nas rochas vulcânicas, rock propõe um jogo de contrastes. sua estrutura assimétrica e seu acabamento interno reflexivo criam um efeito visual surpreendente no ambiente. rock oferece opções de aplicação e acabamento



o designer jean marie massaud se inspirou na natureza para criar solar. sua agradável luminosidade lembra as cores do entardecer, enquanto suas linhas e formas fazem referência ao céu e ao eclipse. versátil, solar é capaz de assumir diferentes ângulos, criando vários efeitos de luz. pode ser usada em ambientes externos

tress

design
marc sadler
fabricante
foscarini

especificações
pg 360



a sedução das tranças femininas serviu de inspiração para o desenvolvimento da luminária tress. fibras de vidro e resina entrelaçadas com uma ordenada casualidade se transformam em estruturas originais. uma ousada combinação entre design e tecnologia que resultou na criação de peças únicas. seus toques gráficos, fortes e persuasivos lembram objetos artesanais



tri-p

design
diesel
fabricante
foscarini

especificações
pg 361



tri-p nasce da ideia da mobilidade contemporânea. um objeto nômade, capaz de se adaptar a espaços diversos, a qualquer hora e em qualquer lugar do mundo. versátil, esta luminária de piso pode ser transportada com facilidade, graças ao seu difusor em tecido elástico e à sua bolsa especial. com uma luz quente e difusa, tri-p é ideal para momentos de relaxamento ou leitura



twiggy

design
marc sadler
fabricante
foscarini

especificações
pg 362



para criar twiggy, o designer marc sadler tomou como ponto de partida um objeto aparentemente simples e despretensioso: uma vara de pescar. linear e longilíneo, este objeto foi transformado em uma luminária leve e flexível, que se adapta a qualquer tipo de ambiente. com linhas amplas e ângulos sofisticados, esta peça garante uma elegância formal e moderna



uto

design
lagranja design
fabricante
foscarini

especificações
pg 363

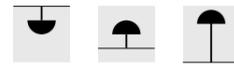

a ideia dos designers gabriele schiavon e gerard sanmartí nasceu da vontade de criar luminárias compostas por formas únicas, flexíveis e divertidas. a dupla utilizou borracha de silicone, um material nunca antes usado na iluminação, para desenvolver uto, uma peça contemporânea, lúdica e maleável, que pode ser usada com aplicação pendente, de piso ou de mesa, tanto em ambientes internos como externos



wish

design
fernando prado
fabricante
lumini

especificações
pg 365



a luminária wish é um exemplo de funcionalidade e praticidade. produzida em alumínio e tecido, ela foi pensada para ocupar o mínimo de espaço com sua base, possibilitando assim um melhor aproveitamento do ambiente



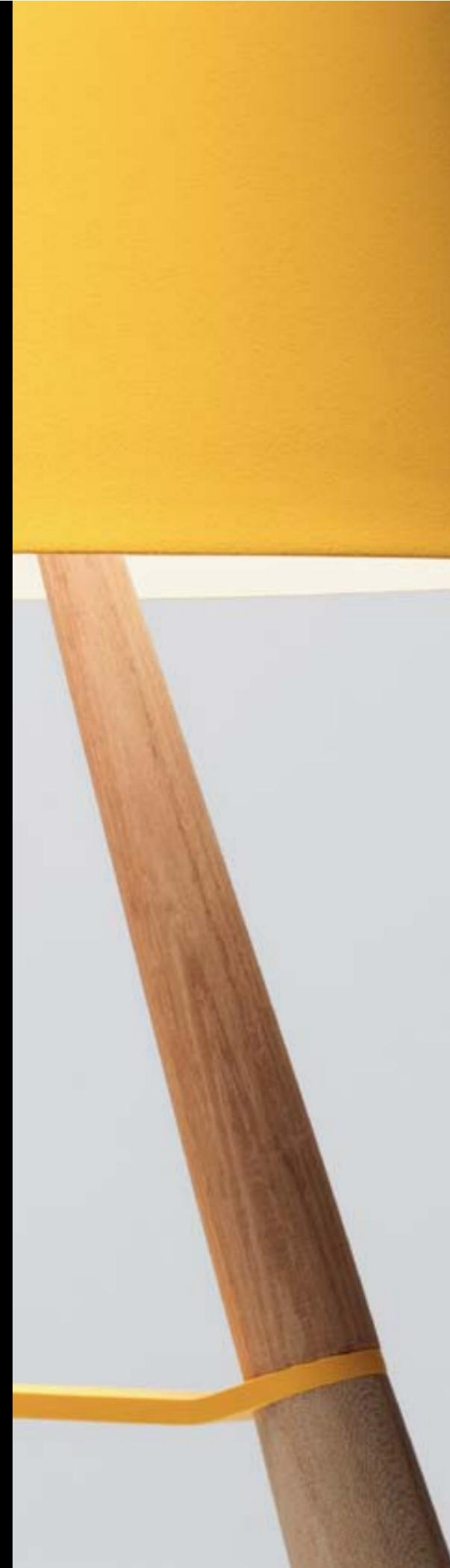
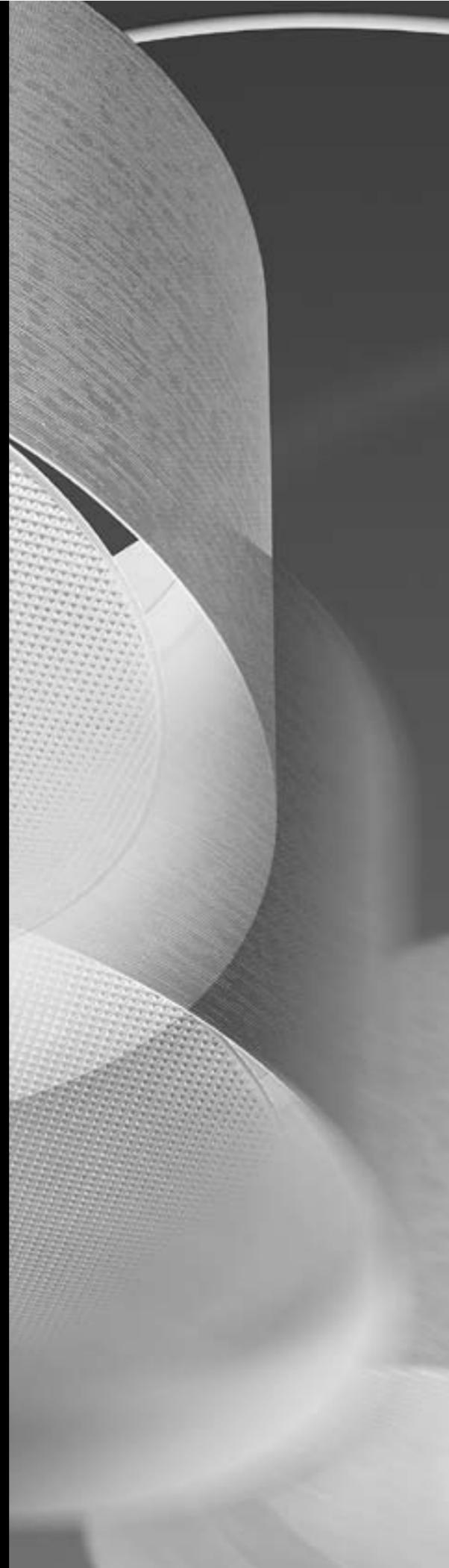

especificações



pendente

material
aço inox
fonte de luz
1x halógena
refletora AR 111
G53 até 50W

uso interno
ip 20

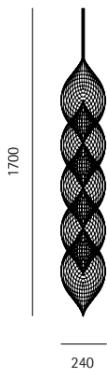

allegretto assai



pendente

materiais
alumínio e aço
esmaltado
cor
oro
fonte de luz
2x halógena PAR
30 E27 até 100W

uso interno
ip 20

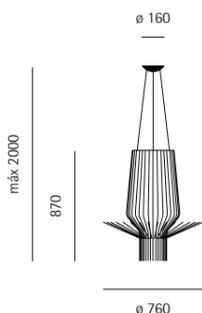

allegretto ritmico



pendente

materiais
alumínio e aço
esmaltado
cor
nero
fonte de luz
2x halógena PAR
30 E27 até 100W

uso interno
ip 20

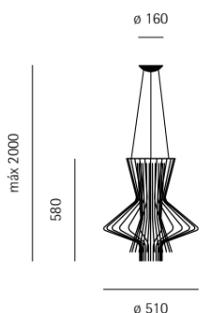

allegretto vivace



pendente

materiais
alumínio e aço
esmaltado
cor
marrone
fonte de luz
2x halógena PAR
30 E27 até 100W

uso interno
ip 20

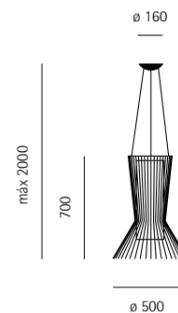

allegro assai



pendente

materiais
alumínio e aço
esmaltado
cor
oro
fonte de luz
1x halógena PAR
30 E27 até 100W

uso interno
ip 20

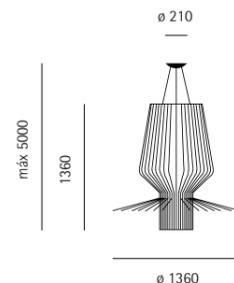

allegro ritmico



pendente

materiais
alumínio e aço
esmaltado
cor
nero
fonte de luz
1x halógena PAR
30 E27 até 100W

uso interno
ip 20

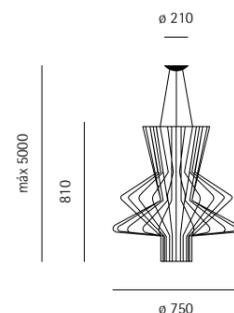

allegro vivace



pendente

materiais
alumínio e aço
esmaltado
cor
marrone
fonte de luz
1x halógena PAR
30 E27 até 100W

uso interno
ip 20

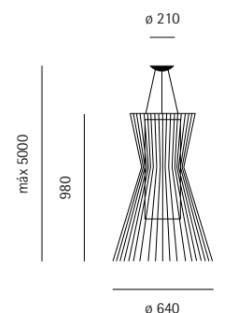

anisha

design
lievore altherr
molina



anisha piccola



mesa
material
ABS
cor
branco
fonte de luz
1x LED 3,4W

uso interno
ip 20

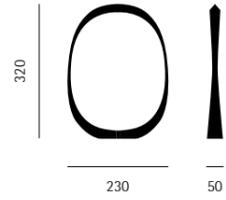

anisha grande



mesa
material
ABS
cor
branco
fonte de luz
1x LED 4,5W

uso interno
ip 20

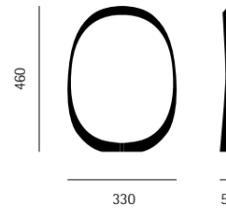

aplomb

design
lucidi
pevere



pendente
material
concreto
cores
branco, grigio
e marrone
fonte de luz
1x halopin com
bulbo fosco G9
até 60W
1x LED 7W
2700k

uso interno
ip 20

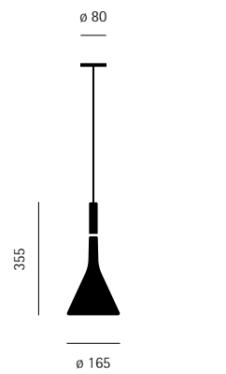

atollo

design
vico magistretti



mesa
material
aluminio laqueado
cores
branco, negro
fonte de luz
2x incandescente
leitosa E27
até 100W

uso interno
ip 20

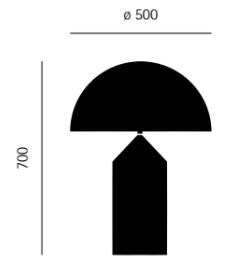

baju

design
fernando prado



mesa
materiais
madeira e tecido
cor
cru
fonte de luz
1x incandescente
leitosa balloon
E27 até 100W
1x halógena E27
até 70W

uso interno
ip 20

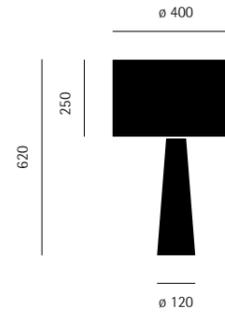

base light

design
tom dixon



base light

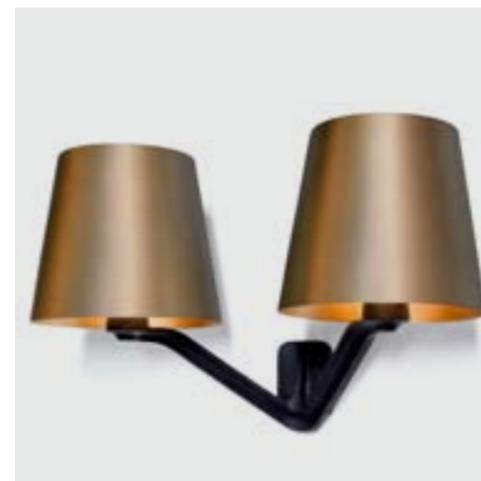

arandela
materiais
brnze e metal
fundido
cor
brass
fonte de luz
2x incandescente
E14 até 40W

uso interno
ip 20

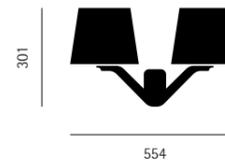

base light



mesa

materiais
bronze e metal
fundido
cor
brass
fonte de luz
1x incandescente
E14 até 40W

uso interno
ip 20

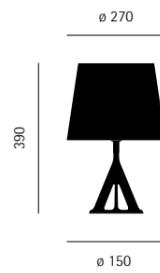

base light



piso

materiais
bronze e metal
fundido
cor
brass
fonte de luz
1x incandescente
leitosa E27
até 100W
1x halógena E27
até 70W

uso interno
ip 20

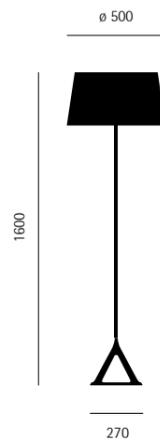

barovier&tosso

design
barovier&tosso

linha ikebana
design
daniela puppa



amsterdam 5562



pendente

materiais
cristal de murano,
metal cromado,
tecido
cores
murano - cara-
melo, cristal,
grigio, rosé, verde
líquido, viola
cúpulas - bianco,
nero

fonte de luz
5x incandescente
E14 até 60W
10x incandescente
E14 até 60W
18x incandescente
E14 até 60W

uso interno
ip 20

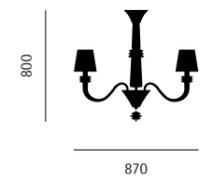

5562/05

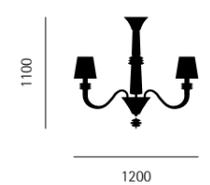

5562/10

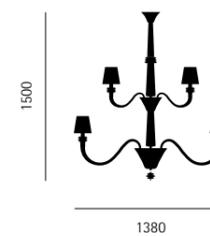

5562/18

taif 5350



pendente

material
cristal de murano
cores
arancio liquido,
bianco, bluastro,
giallo liquido,
grigio, nero, rosso,
verde liquido,
viola
fonte de luz
6x incandescente
E14 até 60W
12x incandescente
E14 até 60W
18x incandescente
E14 até 60W

uso interno
ip 20

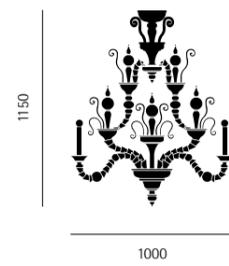

5350/06

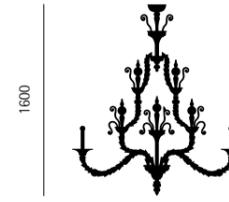

5350/12

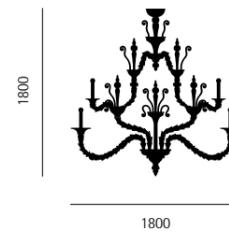

5350/18

maryland 5587



pendente

materiais
cristal de murano,
metal cromado,
tecido
cores
murano - acqua-
mare, cristallo,
cedro liquido,
grigio
cúpulas - bianco,
nero
fonte de luz
7x incandescente
E14 até 60W
15x incandescente
E14 até 60W
27x incandescente
E14 até 60W

uso interno
ip 20

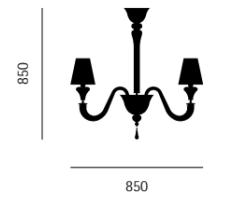

5587/07

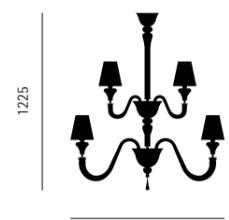

5587/15

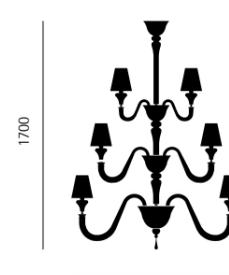

5587/27

ikebana 6919



mesa

materiais
vidro e tecido
cores
bianco, nero
fonte de luz
3x incandescente
E14 até 60W

uso interno
ip 20

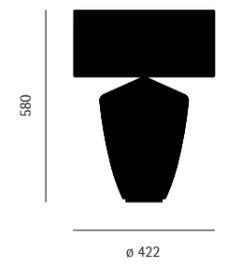

ikebana 6920



mesa

materiais
vidro e tecido
cores
bianco, nero
fonte de luz
3x incandescente
E14 até 60W

uso interno
ip 20

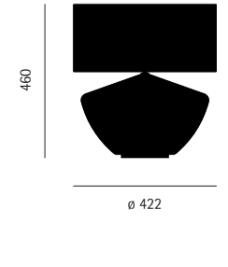

lara 5568



mesa

materiais
cristal de murano,
metal cromado
e tecido
cores
murano - arancio
liquido, brown,
cristallo, giallo
liquido, grigio,
verde antalia,
verde liquido,
viola
cúpula - bianco,
nero

fonte de luz
1x incandescente
leitosa E27
até 100W
1x halógena E27
até 70W

uso interno
ip 20

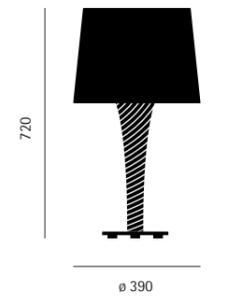

marta 5576



mesa

materiais
cristal de murano,
metal cromado
e tecido
cores
murano - arancio
liquido, brown,
cristallo, giallo
liquido, grigio,
verde antalia,
verde liquido,
viola
cúpula - bianco,
nero

fonte de luz
1x incandescente
leitosa E27
até 100W
1x halógena E27
até 70W

uso interno
ip 20

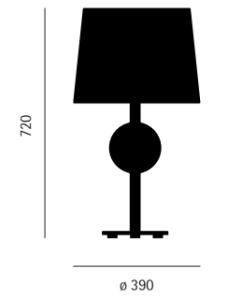

sara 5574



mesa

materiais
cristal de murano,
metal cromado
e tecido
cores
murano - brown,
cristallo, grigio,
verde antalia,
viola
cúpula - bianco,
nero
fonte de luz
1x incandescente
leitosa E27
até 100W
1x halógena E27
até 70W

uso interno
ip 20

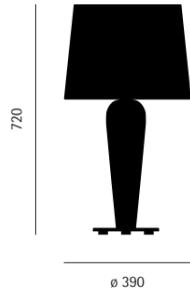

vania 5572



mesa

materiais
cristal de murano,
metal cromado
e tecido
cores
murano - arancio
liquido, brown,
cristallo, giallo
liquido, grigio,
verde antalia,
verde liquido,
viola
cúpula - bianco,
nero

fonte de luz
1x incandescente
leitosa E27
até 100W
1x halógena E27
até 70W

uso interno
ip 20

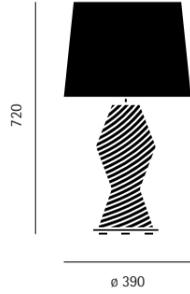

bauhaus 90 T



mesa

materiais
alumínio e aço
cromado
cores
branco fosco
texturizado,
grafite e preto
fosco texturizado
fonte de luz
1x halopin com
bulbo fosco G9
até 40W
1x LED 4W
warm white

uso interno
ip 20

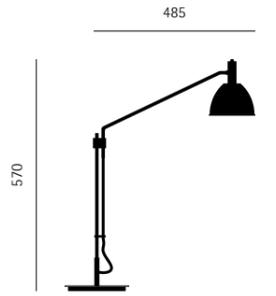

bauhaus 90



piso

materiais
alumínio e aço
cromado
cores
branco fosco
texturizado,
grafite e preto
fosco texturizado
fonte de luz
1x incandescente
leitosa E27
até 100W
1x halógena E27
até 70W
1x LED 4W (warm
white)uso interno

uso interno
ip 20

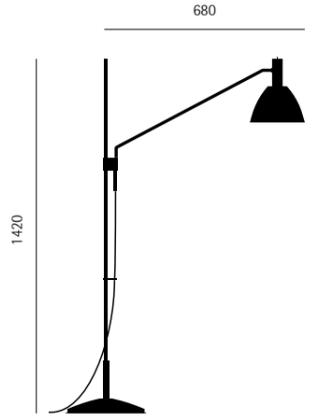

bauhaus 90

design
fernando prado



beat

design
tom dixon



bauhaus 90 W



arandela

materiais
alumínio e aço
cromado
cores
branco fosco
texturizado,
grafite e preto
fosco texturizado
fonte de luz
1x halopin com
bulbo fosco G9
até 40W
1x LED 4W warm
white

uso interno
ip 20

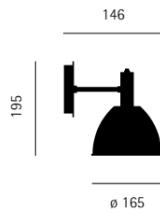

beat light fat

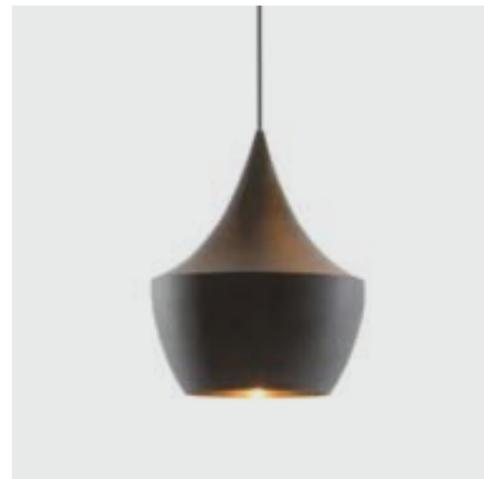

pendente

materiais
bronze e pátina
cor
black, white
fonte de luz
1x halopin com
bulbo fosco G9
até 25W

uso interno
ip 20

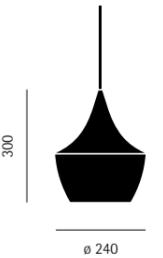

beat light stout



pendente
materiais
bronze e pátina
cor
black, white
fonte de luz
1x halopin com
bulbo fosco G9
até 25W

uso interno
ip 20

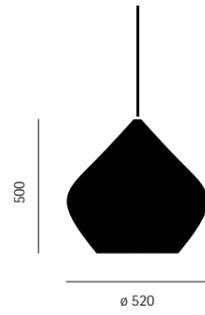

berenice

design
paolo rizzatto
alberto meda



berenice

arandela
materiais
alumínio fundido
e cristal prensado
cores
alu, black, blue,
green, ivory, red
fonte de luz
1x halógena
bipino GY6,35
até 35W



uso interno
ip 20

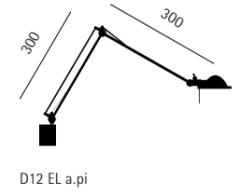

D12 EL a.pi

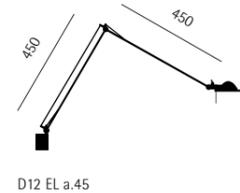

D12 EL a.45

beat light tall



pendente
materiais
bronze e pátina
cor
black, white
fonte de luz
1x halopin com
bulbo fosco G9
até 25W

uso interno
ip 20

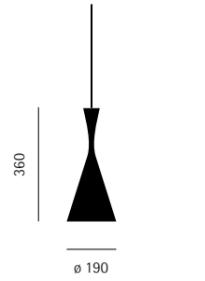

berenice

mesa
materiais
alumínio fundido
e cristal prensado
cores
alu, black, blue,
green, ivory, red
fonte de luz
1x halógena
bipino GY6,35
até 35W

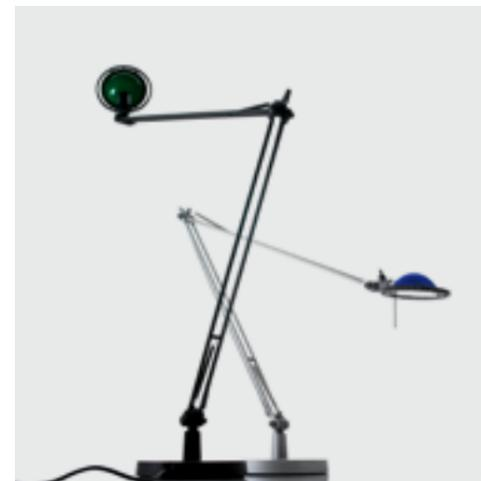

uso interno
ip 20

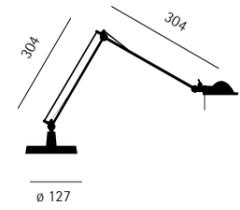

D12 EL

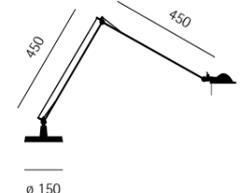

D12 EL pi

beat light wide



pendente
materiais
bronze e pátina
cor
black, white
fonte de luz
1x halopin com
bulbo fosco G9
até 25W

uso interno
ip 20

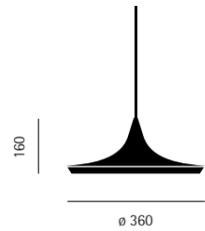

behive

design
werner aisslinger



mesa
materiais
policarbonato
e ABS
cor
bianco
fonte de luz
1x incandescente
leitosa E27
até 100W
1x halógena E27
até 70W

uso interno
ip 20

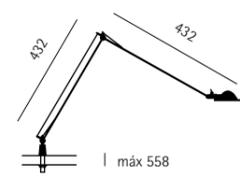
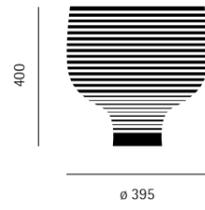

D12 EL pt

berenice led



mesa

materiais
alumínio fundido e cristal prensado
cores
alu, black
fonte de luz
1x LED 8W warm white 220V
1x LED 10W warm white 110V

uso interno
ip 20

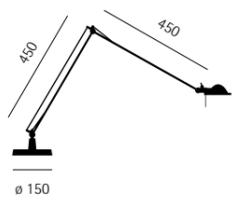

binic

design
ionna vautrin



mesa

materiais
policarbonato e ABS
cores
amaranto, arancio, bianco, grigio, petrolio, verde
fonte de luz
1x fluorescente compacta eletrônica E27 até 12W

uso interno
ip 20

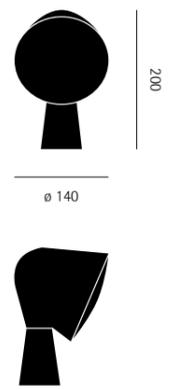

berenice



piso

materiais
alumínio fundido e cristal prensado
cores
alu, black, blue, green, ivory, red
fonte de luz
1x halógena bipino GY6,35 até 35W

uso interno
ip 20

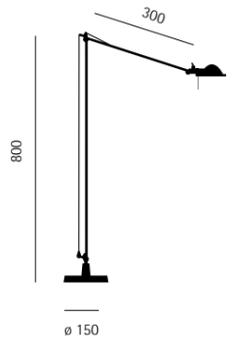

birdie

design
ludovica roberto palomba



big bang

design
enrico franzolini vicente garcia jimenez



pendente

material
metacrilato
cores
bianco, rosso
fonte de luz
1x halógena palito R7s até 200W

uso interno
ip 20

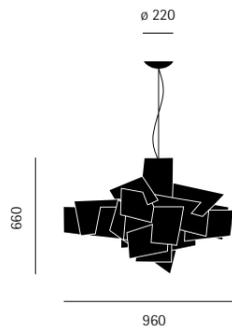

birdie



mesa

materiais
aço laqueado e policarbonato
cores
amaranto, arancio, bianco, grigio
fonte de luz
1x incandescente leitosa E27 até 100W
1x halógena E27 até 70W

uso interno
ip 20

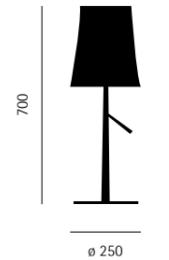

bill

design
tobias grau



mesa

material
alumínio
fonte de luz
1x halopin bulbo fosco até 60W

uso interno
ip 20

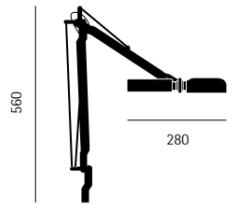

birdie



piso

materiais
aço laqueado e policarbonato
cores
amaranto, arancio, bianco, grigio
fonte de luz
1x halógena E27 até 70W
1x incandescente leitosa E27 até 100W

uso interno
ip 20

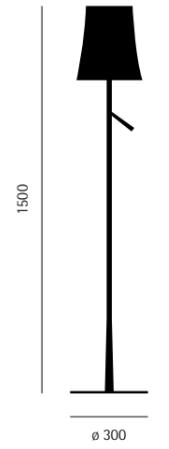



14.1



pendente
materiais
metal e vidro
fundido
cor
transparent
fonte de luz
1x xenon
bipino 10W

uso interno
ip 20

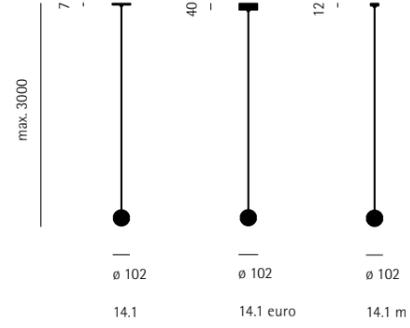

14.5

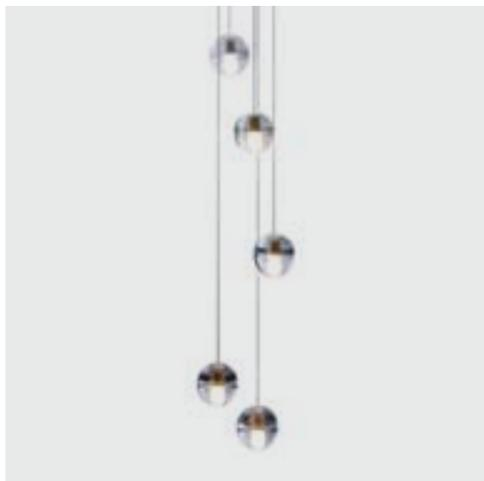

pendente
materiais
metal e vidro
fundido
cor
transparent
fonte de luz
5x xenon
bipino 10W

uso interno
ip 20

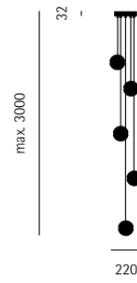

14.14

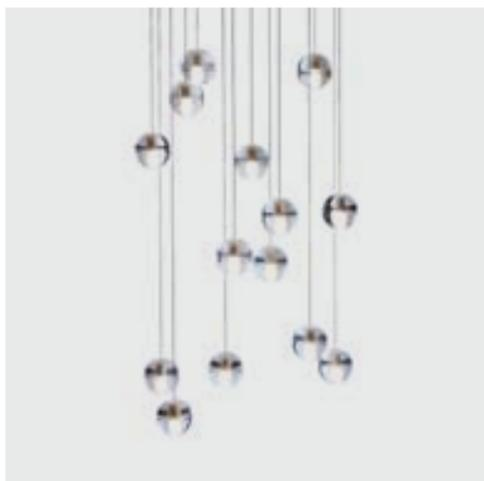

pendente
materiais
metal e vidro
fundido
cor
transparent
fonte de luz
14x xenon
bipino 10W

uso interno
ip 20

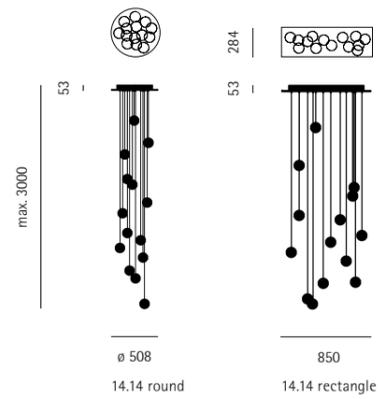

14.36

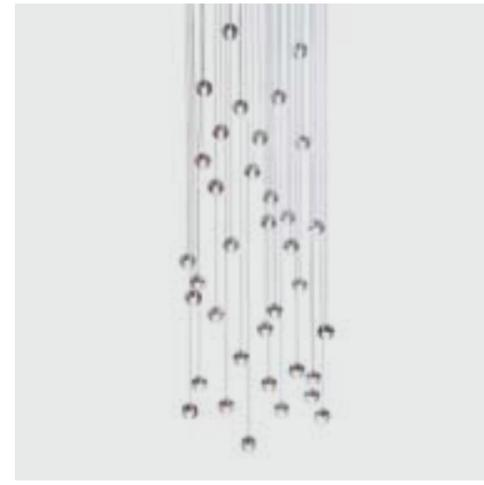

pendente
materiais
metal e vidro
fundido
cor
transparent
fonte de luz
36x xenon
bipino 10W

uso interno
ip 20

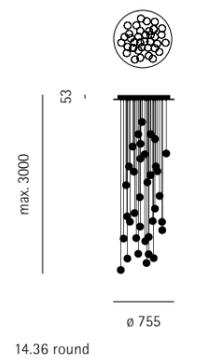

14.36 round

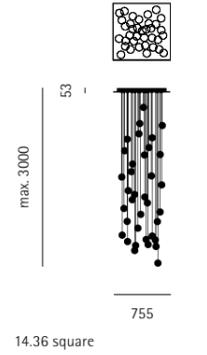

14.36 square

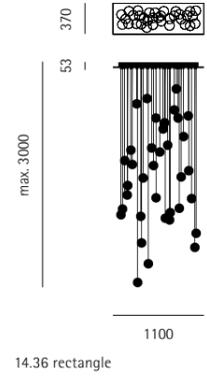

14.36 rectangle

14.5



aplicada
arandela

material
vidro fundido
cor
transparent
fonte de luz
1x xenon
bipino 10W

uso interno
ip 20

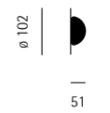

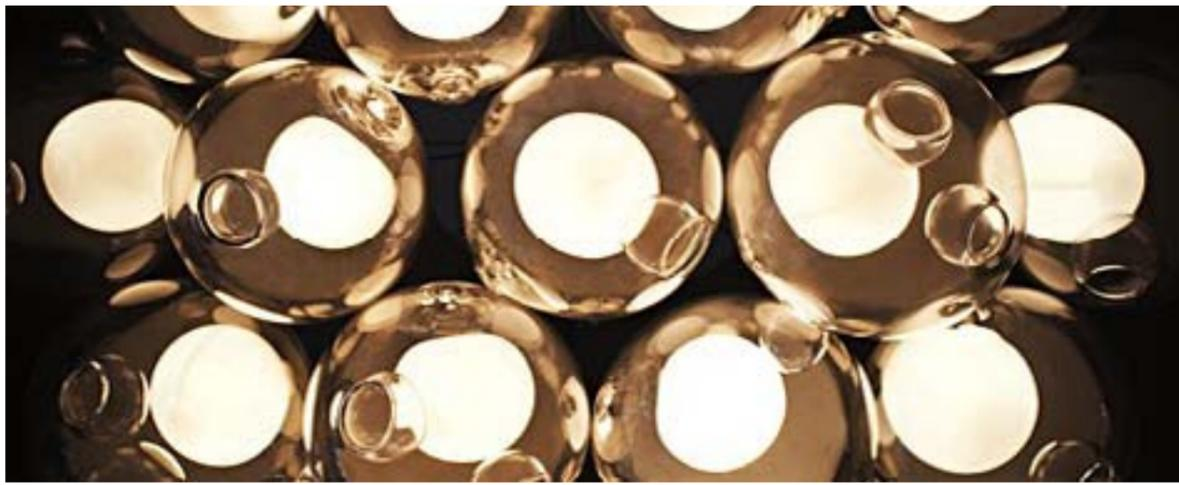

28.1



pendente
materiais
metal e vidro
soprado
cores
sob consulta
fonte de luz
1x xenon
bipino 20W
uso interno
ip 20

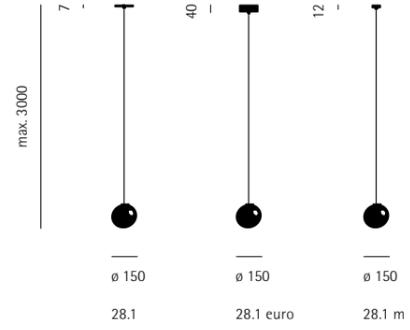

28.7

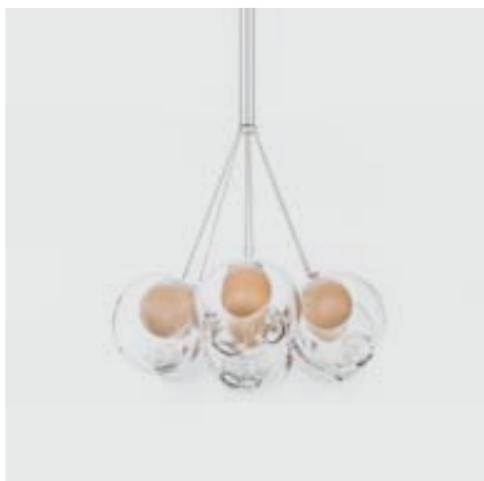

pendente
materiais
metal e vidro
soprado
cores
sob consulta
fonte de luz
7x xenon
bipino 20W
uso interno
ip 20

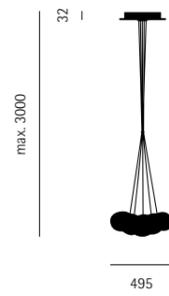

28.19



pendente
materiais
metal e vidro
soprado
cores
sob consulta
fonte de luz
19x xenon
bipino 20W
uso interno
ip 20

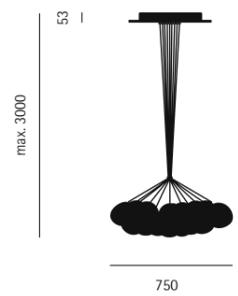

28.37



pendente
materiais
metal e vidro
soprado
cores
sob consulta
fonte de luz
37x xenon
bipino 20W
uso interno
ip 20

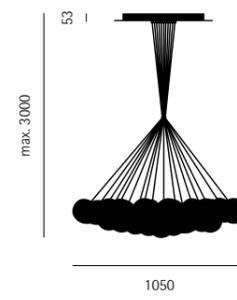

blow

design
ferdi giardini

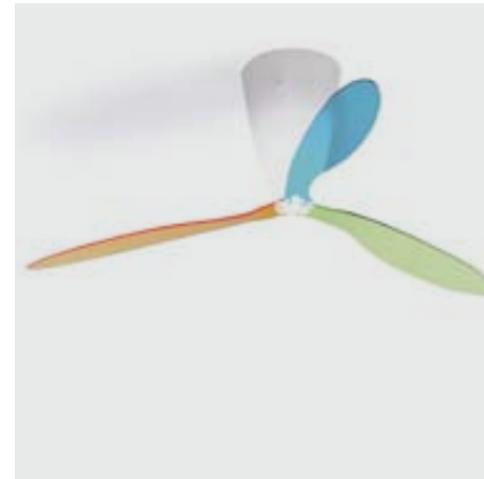

aplicada
material
metacrilato
cores
blue, green,
orange, white
fonte de luz
1x incandescente
leitosa E27
até 100W
uso interno
ip 20

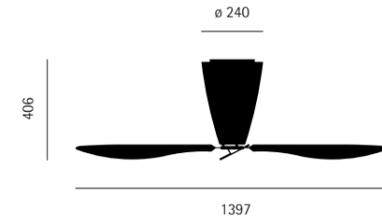

bossa

design
fernando prado

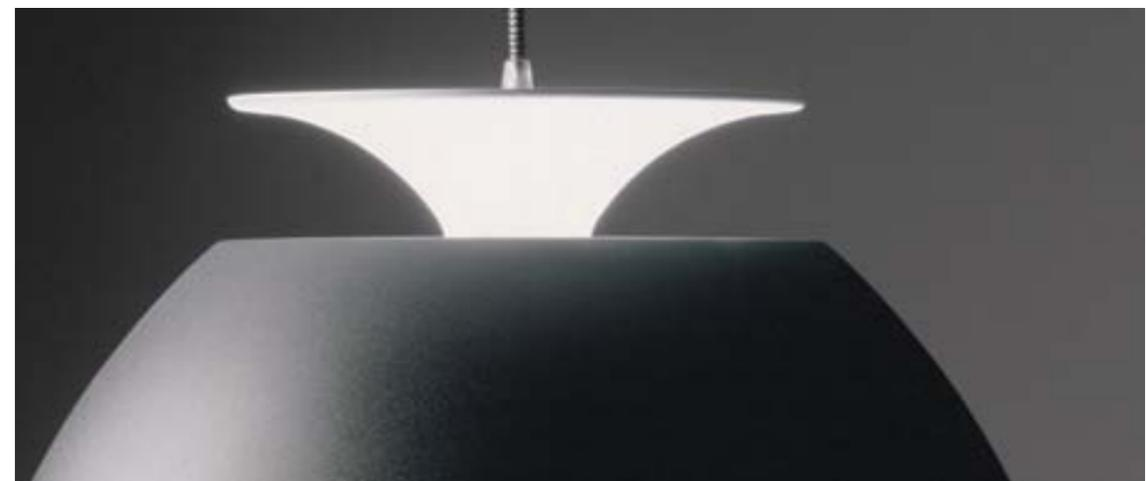

mini bossa



pendente
material
aluminio
cores
branco fosco
texturizado,
cobre, grafite,
prata, preto fosco
texturizado
fonte de luz
1x halopin com
bulbo fosco G9
até 60W
uso interno
ip 20

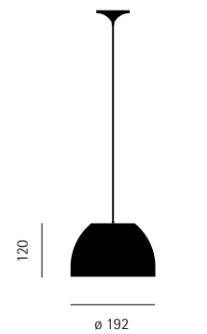

bossinha



pendente

material
alumínio
cores
branco fosco
texturizado,
cobre, grafite,
prata, preto fosco
fonte de luz
1x incandescente
leitosa E27
até 100W
1x halógena E27
até 70W

uso interno
ip 20

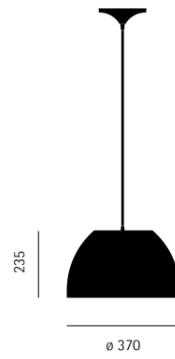

caboché

design
eliana gerotto
patricia urquiola



bossa



pendente

material
alumínio
cores
branco fosco
texturizado,
cobre, grafite,
prata, preto fosco
fonte de luz
1x incandescente
leitosa E27
até 100W
1x halógena E27
até 70W

uso interno
ip 20

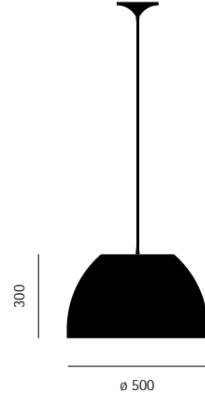

caboché pequena



pendente

materiais
polimetilmeta-
crlato e vidro
soprado
cores
giallo oro,
transparente
fonte de luz
1x halopin com
bulbo fosco G9
até 60W

uso interno
ip 20



super bossa



pendente

material
alumínio
cores
branco fosco
texturizado,
cobre, grafite,
prata, preto fosco
fonte de luz
1x incandescente
leitosa E27
até 200W
1x halógena E27
até 70W

uso interno
ip 20

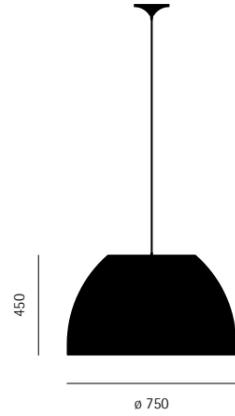

caboché media



pendente

materiais
polimetilmeta-
crlato e vidro
soprado
cores
giallo oro,
transparente
fonte de luz
1x halógena palito
até 150W

uso interno
ip 20

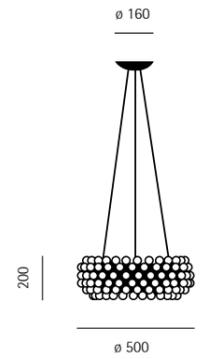

bridge

design
fernando prado



piso

materiais
aço inox e feltro
cor
branco
fonte de luz
1x incandescente
E27 até 100W

uso interno
ip 20

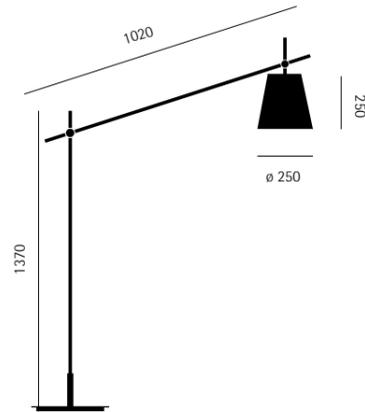

caboché grande



pendente

materiais
polimetilmeta-
crlato e vidro
soprado
cores
giallo oro,
transparente
fonte de luz
1x halógena palito
até 200W

uso interno
ip 20

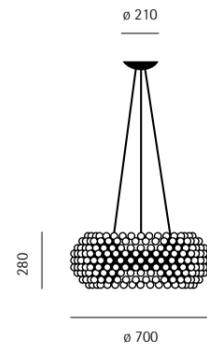

caboché

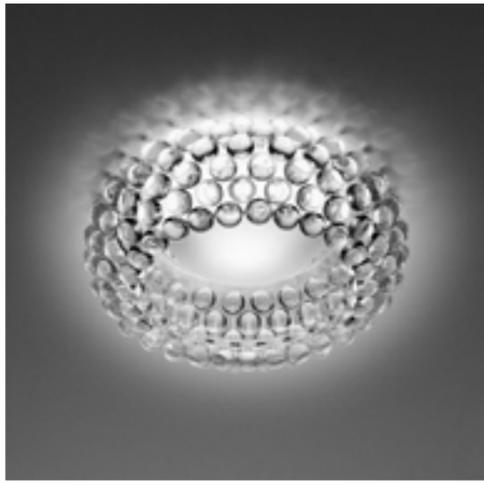

aplicada
materiais
polimetilmeta-
crilato e vidro
soprado
cor
transparente
fonte de luz
1x halógena palito
R7s até 100W

uso interno
ip 20

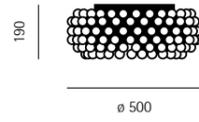

cage

design
diesel



caboché piccola



arandela
materiais
polimetilmeta-
crilato e vidro
soprado
cores
giallo oro, trans-
parente
fonte de luz
1x halógena palito
R7s até 100W

uso interno
ip 20

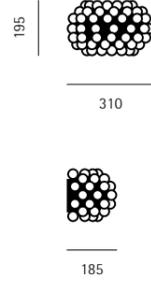

cage piccola

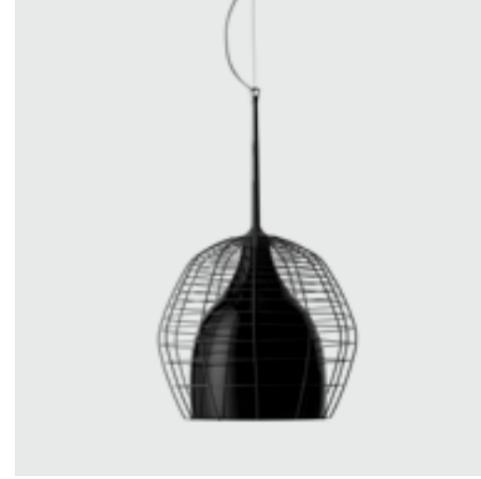

pendente
materiais
metal laqueado
e vidro soprado
cores
bianco, nero
fonte de luz
1x fluorescente
compacta eletrô-
nica E27 até 25W

uso interno
ip 20

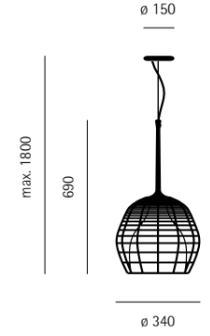

caboché media



arandela
materiais
polimetilmeta-
crilato e vidro
soprado
cores
giallo oro, trans-
parente
fonte de luz
1x halógena palito
R7s até 100W

uso interno
ip 20

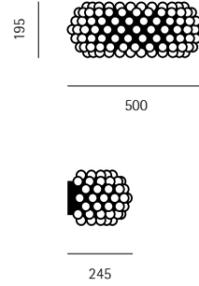

cage grande

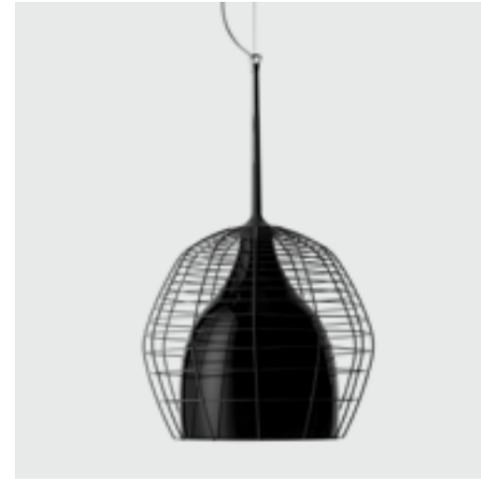

pendente
materiais
metal laqueado
e vidro soprado
cores
bianco, nero
fonte de luz
1x fluorescente
compacta eletrô-
nica E27 até 25W

uso interno
ip 20

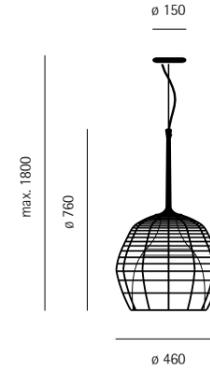

cage mic



pendente
materiais
metal laqueado
e vidro soprado
cores
bianco, nero
fonte de luz
1x halopin com
bulbo fosco G9
até 40W

uso interno
ip 20

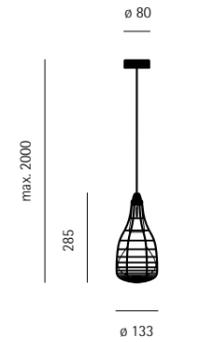

cage mic



mesa

materiais
metal laqueado
e vidro soprado
cores
branco, negro
fonte de luz
1x halopin com
bulbo fosco G9
até 40W

uso interno
ip 20

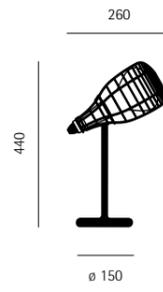

chouchin

design
ionna vautrin



cage rocket



mesa

materiais
metal laqueado
e vidro soprado
cores
branco, negro
fonte de luz
1x halopin com
bulbo fosco G9
até 40W

uso interno
ip 20

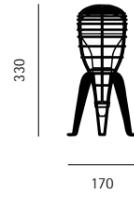

chouchin 1



pendente

material
vidro soprado
cor
arancio
fonte de luz
1x halógena PAR
30 E27 até 75W

uso interno
ip 20

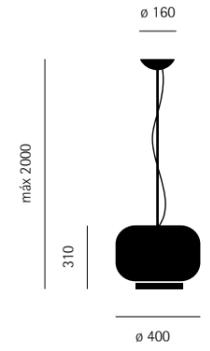

cage



piso

materiais
metal laqueado
e vidro soprado
cores
branco, negro
fonte de luz
1x fluorescente
compacta eletrô-
nica E27 até 25W

uso interno
ip 20

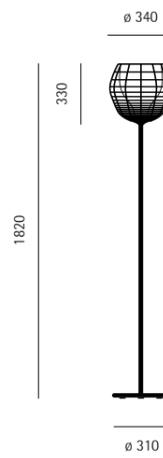

chouchin 2



pendente

material
vidro soprado
cor
verde
fonte de luz
1x halógena PAR
30 E27 até 75W

uso interno
ip 20

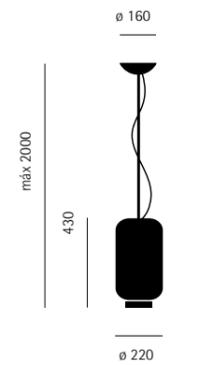

carrara

design
alfredo häberli



piso

material
poliuretano
expandido
cores
black, white
fonte de luz
1x halógena palito
R7s até 300W

uso interno
ip 20

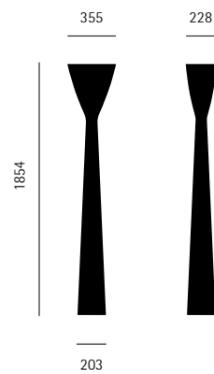

chouchin 3



pendente

material
vidro soprado
cor
grigio
fonte de luz
1x halógena PAR
30 E27 até 75W

uso interno
ip 20

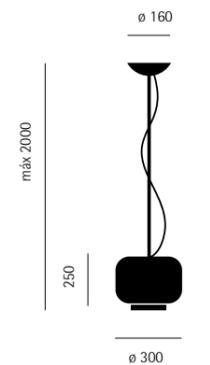



copper shade



pendente

materiais
cobre
e policarbonato
cor
copper
fonte de luz
1x incandescente
leitosa E27
até 100W
1x halógena E27
até 60W

uso interno
ip 20

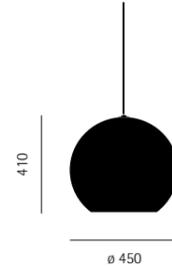

fat spot



mesa
piso

materiais
cobre e polycarbonato
cor
copper
fonte de luz
1x incandescente
leitosa E27
até 100W
1x halógena E27
até 70W

uso interno
ip 20

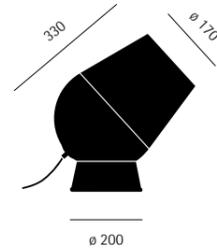

costanza



pendente

materiais
alumínio
e policarbonato
acetinado
cores
blue, orange,
pistacho, black,
white
fonte de luz
1x incandescente
leitosa E27
até 100W
1x halógena E27
até 70W

uso interno
ip 20

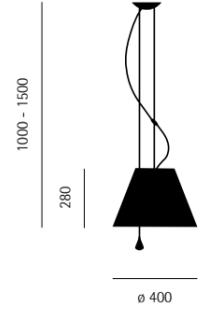

costanza



mesa

materiais
alumínio e polycarbonato acetinado
cores
blue, orange,
pistacho, black,
white
fonte de luz
1x incandescente
leitosa E27
até 100W
1x halógena E27
até 70W

uso interno
ip 20



costanza



piso

materiais
alumínio e poli-carbonato acetinado
cores
blue, orange, pistacho, black, white
fonte de luz
1x incandescente leitosa E27 até 100W
1x halógena E27 até 150W

uso interno
ip 20

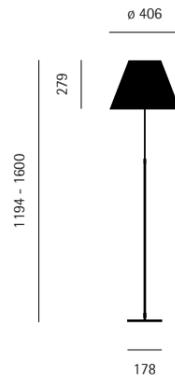
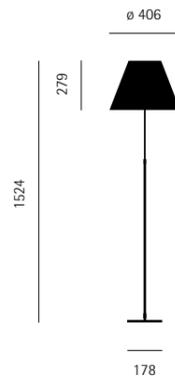

costanzina

design
paolo rizzatto



costanzina



pendente

materiais
policarbonato acetinado
cores
blue, orange, pistacho, black, white
fonte de luz
1x incandescente E14 até 60W

uso interno
ip 20

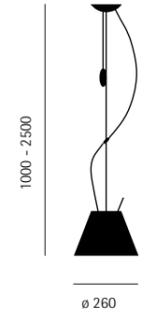

grande costanza open air



piso

materiais
alumínio e poli-carbonato acetinado
cores
blue, orange, pistacho, black, white
fonte de luz
1x fluorescente compacta até 23W

uso externo
ip 54

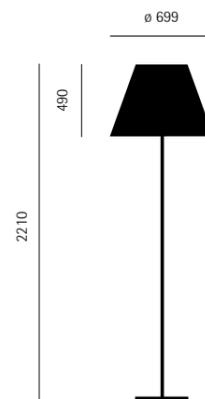

costanzina



arandela

materiais
aço inoxidável e policarbonato acetinado
cores
blue, orange, pistacho, black, white
fonte de luz
1x incandescente leitosa E27 até 60W
1x halógena E27 até 60W

uso interno
ip 20

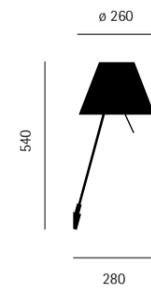

lady costanza



piso

materiais
alumínio e poli-carbonato acetinado
cores
black, white
fonte de luz
1x incandescente leitosa E27 até 100W
1x halógena E27 até 70W

uso interno
ip 20

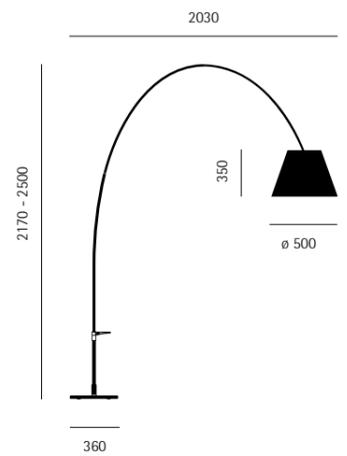

costanzina



mesa

materiais
aço inoxidável e policarbonato acetinado
cores
blue, orange, pistacho, black, white
fonte de luz
1x incandescente leitosa E27 até 60W
1x halógena E27 até 60W

uso interno
ip 20

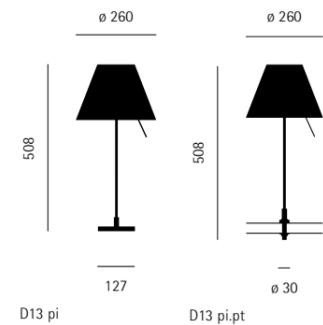



eclipse

design
fernando prado

duii mini



arandela

materiais
policarbonato
e vidro**cores**
giallo, grigio**fonte de luz**
1x halopin com
bulbo fosco G9
até 40Wuso interno
ip 20

mini eclipse

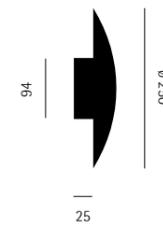

arandela

materiais
alumínio tratado
e pintura eletros-
tática**cor**
branco fosco
texturizado**fonte de luz**
4x halopin com
bulbo fosco G9
até 25Wuso interno
ip 20

duii

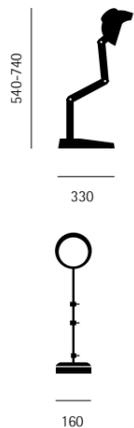

mesa

materiais
policarbonato
e vidro**cores**
giallo, grigio**fonte de luz**
1x halopin com
bulbo fosco G9
até 40Wuso interno
ip 20

eclipse

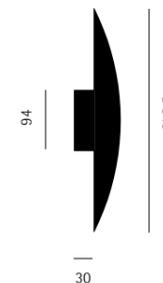

arandela

materiais
alumínio tratado
e pintura eletros-
tática**cor**
branco fosco
texturizado**fonte de luz**
4x halopin com
bulbo fosco G9
até 25Wuso interno
ip 20

duii mini



mesa

materiais
policarbonato
e vidro**cores**
giallo, grigio**fonte de luz**
1x halopin com
bulbo fosco G9
até 40Wuso interno
ip 20

super eclipse

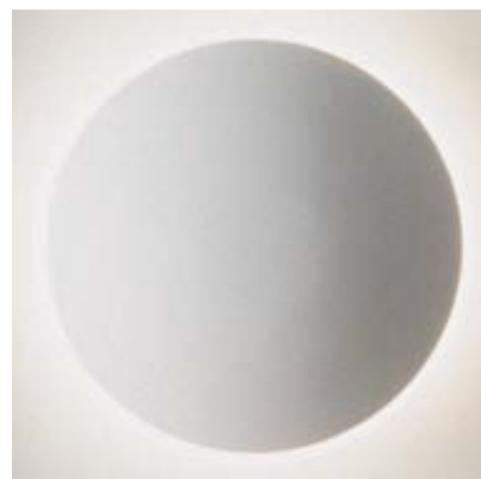

arandela

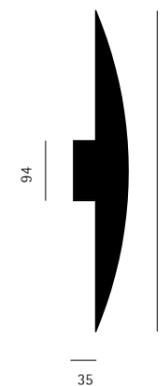
materiais
alumínio tratado
e pintura eletros-
tática**cor**
branco fosco
texturizado**fonte de luz**
4x halopin com
bulbo fosco G9
até 25Wuso interno
ip 20

esa

design
lievore altherr
molina



fina

design
fernando prado



piso

materiais
aço inox escovado, alumínio e pintura eletrostática
cores
branco fosco texturizado, grafite, preto fosco texturizado
fonte de luz
1x halógena palito 200W

uso interno
ip 20

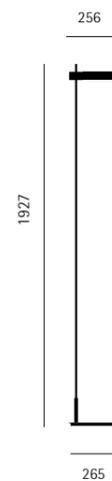

esa 07 piccola



mesa

materiais
alumínio escovado e vidro soprado
cores
avorio, branco
fonte de luz
1x halopin com bulbo fosco G9 até 40W

uso interno
ip 20

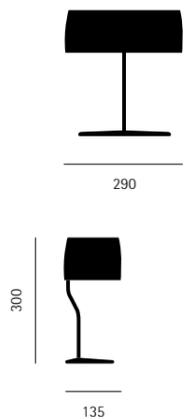

fool

design
fernando prado



esa 07 grande



mesa

materiais
alumínio escovado e vidro soprado
cores
avorio, branco
fonte de luz
1x incandescente leitosa E27 até 100W
1x halógena E27 até 70W

uso interno
ip 20

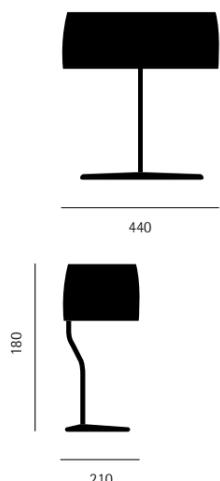

mini fool



mesa

materiais
aço inox, aço, alumínio e feltro
cores
base – azul claro, azul marinho, azul turquesa, branco fosco texturizado, fúcsia, grafite, laranja, mostarda, preto fosco texturizado, rosa, titânio, verde claro, verde médio, verde oliva, vermelho
cúpula – cinza, branco

fonte de luz
1x halopin até 60W
uso interno
ip 20

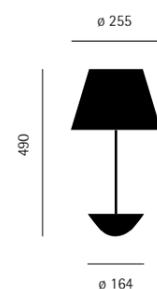

etch shade

design
tom dixon

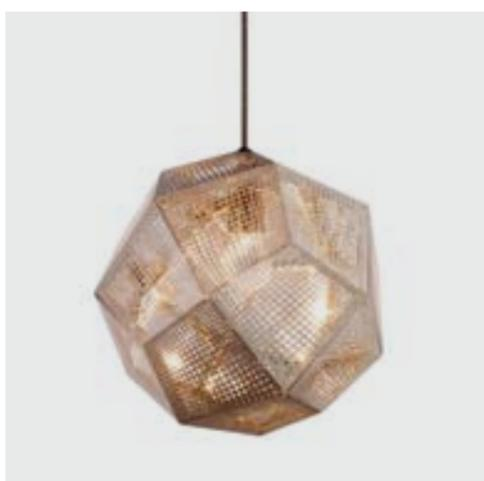

pendente

material
metal
cores
brass, copper, stainless steel
fonte de luz
1x halógena E27 até 40W

uso interno
ip 20

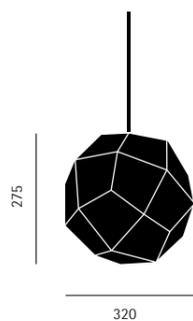

fool



mesa

materiais
aço inox, aço, alumínio e feltro
cores
base – azul claro, azul marinho, azul turquesa, branco fosco texturizado, fúcsia, grafite, laranja, mostarda, preto fosco texturizado, rosa, titânio, verde claro, verde médio, verde oliva, vermelho
cúpula – cinza, branco

fonte de luz
1x incandescente até 100W
uso interno
ip 20

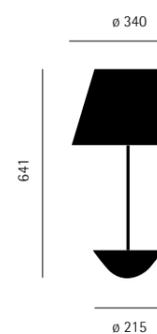



piso

materiais
metal anodizado
e tecido
cores
avorio, grigio
fonte de luz
1x halógena palito
R7s até 120W

uso interno
ip 20

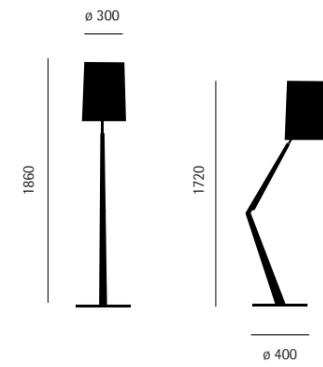

fork piccola



pendente

materiais
metal anodizado
e tecido
cores
avorio, grigio
fonte de luz
1x halógena palito
R7s até 48W

uso interno
ip 20

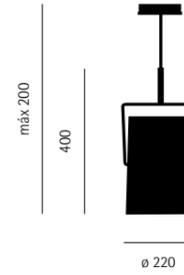

fortebraccio

design
alberto meda

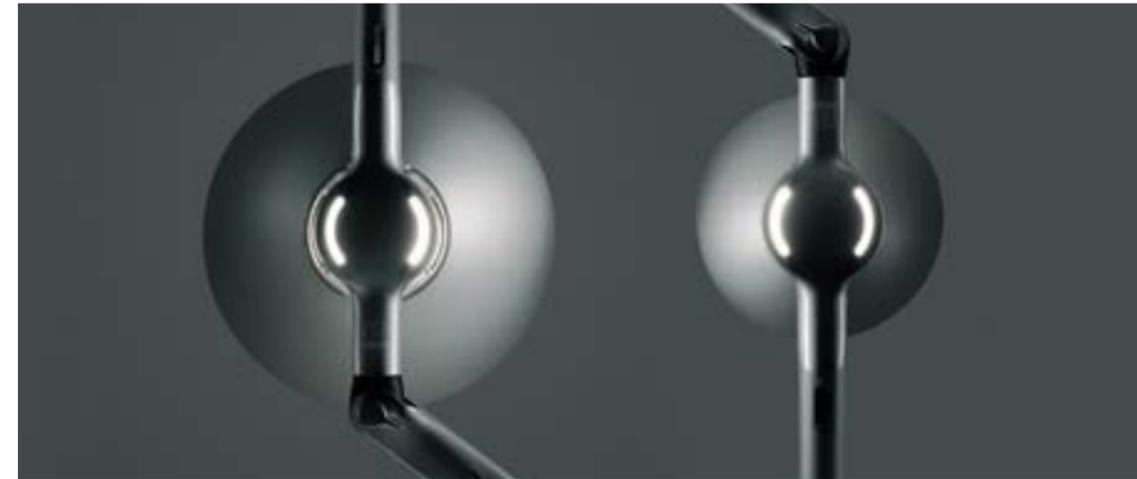

fork grande



pendente

materiais
metal anodizado
e tecido
cores
avorio, grigio
fonte de luz
1x halógena palito
R7s até 120W

uso interno
ip 20

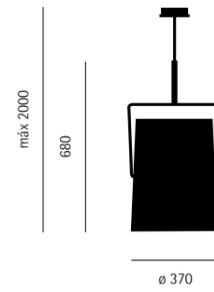

fortebraccio



arandela

materiais
policarbonato
e aço
cores
alu, black, white
fonte de luz
1x incandescente
leitosa E27
até 100W
1x halógena E27
até 70W

uso interno
ip 20

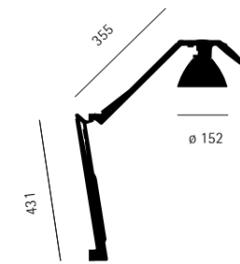

fork



mesa

materiais
metal anodizado
e tecido
cores
avorio, grigio
fonte de luz
1x halógena palito
R7s até 48W

uso interno
ip 20

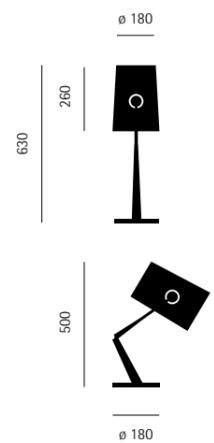

fortebraccio



arandela

materiais
policarbonato
e aço
cores
alu, black, white
fonte de luz
1x incandescente
leitosa E27
até 100W
1x halógena E27
até 70W

uso interno
ip 20

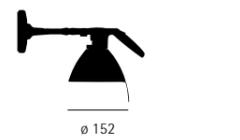

fortebraccio



mesa

materiais
policarbonato e aço
cores
alu, white
fonte de luz
1x incandescente leitosa E27 até 100W
1x halógena E27 até 70W

uso interno
ip 20

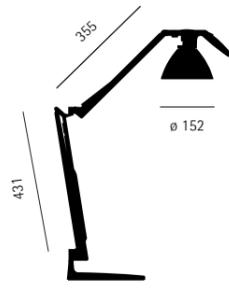

glas

design
diesel



fortebraccio



piso

materiais
policarbonato e aço
cores
alu, black, white
fonte de luz
1x incandescente leitosa E27 até 100W
1x halógena E27 até 70W

uso interno
ip 20

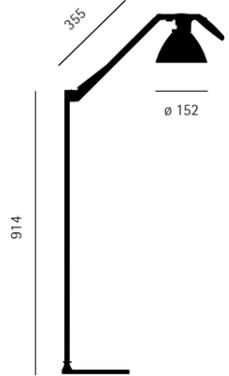

glas
piccola



pendente

materiais
vidro soprado e alumínio
cor
cromo
fonte de luz
1x fluorescente compacta eletrônica E27 até 21W

uso interno
ip 20

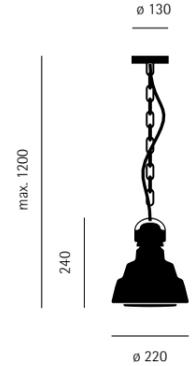

ginga

design
fabio falanghe
giorgio giorgi



mesa

material
alumínio
cores
azul claro, azul marinho, azul turquesa, branco fosco texturizado, fúcsia, grafite, laranja, mostarda, preto fosco texturizado, rosa, titânio, verde claro, verde médio, verde oliva, vermelho

fonte de luz
1x halopin com bulbo fosco até 60W
1x LED 4W warm white

uso interno
ip 20

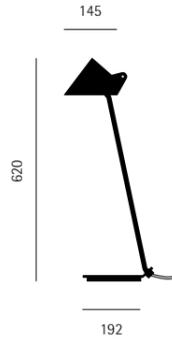

glas
grande

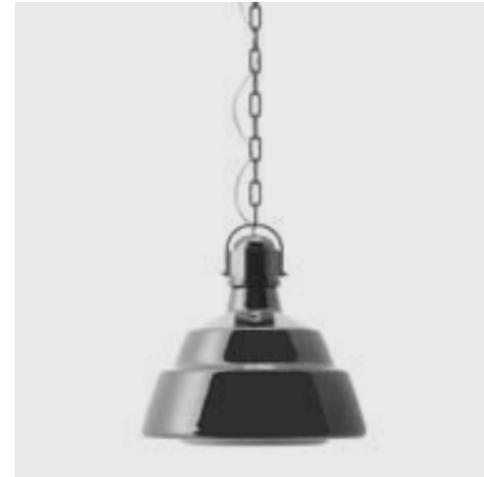

pendente

materiais
vidro soprado e alumínio
cor
cromo
fonte de luz
1x fluorescente compacta eletrônica E27 até 21W
1x halógena E27 até 105W

uso interno
ip 20

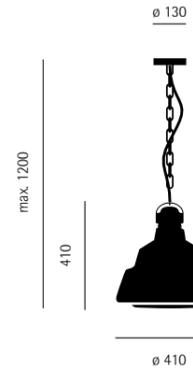

glas



mesa

materiais
alumínio e vidro soprado
cor
cromo
fonte de luz
1x fluorescente compacta eletrônica E27 até 21W

uso interno
ip 20

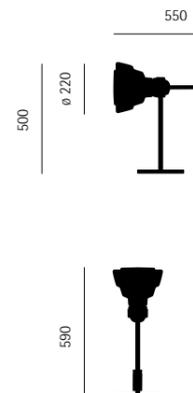



glassglass piccolo



pendente
arandela

materiais
metal e vidro
soprado
cor
white
fonte de luz
1x incandescente
leitosa E27
até 100W
1x halógena E27
até 250W

uso interno
ip 20

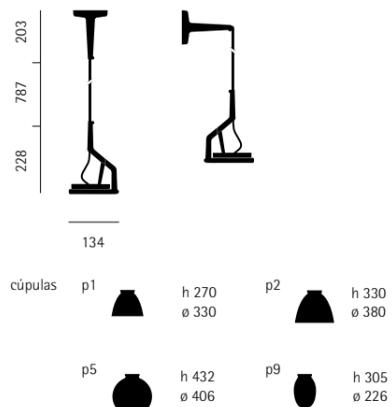

glassglass grande



pendente
arandela

materiais
metal e vidro
soprado
cor
white
fonte de luz
1x incandescente
leitosa E27
até 100W
1x halógena E27
até 70W

uso interno
ip 20



gregg piccola



pendente

materiais
vidro soprado
cor
bianco
fonte de luz
1x halopin
com bulbo fosco
G9 até 40W

uso interno
ip 20

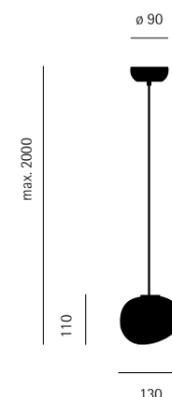

gregg media



pendente

materiais
vidro soprado
cor
bianco
fonte de luz
1x incandescente
leitosa até 100W

uso interno
ip 20

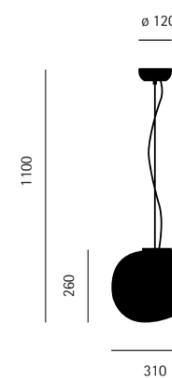

gregg grande

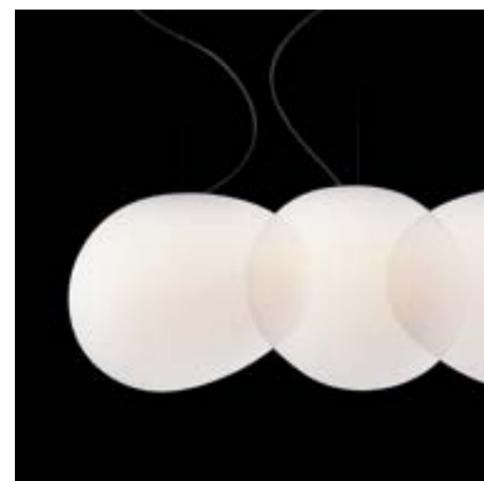

pendente

materiais
vidro soprado
cor
bianco
fonte de luz
1x incandescente
leitosa E27
até 100W
1x halógena E27
até 205W
1x fluorescente
compacta eletrô-
nica até 30W

uso interno
ip 20

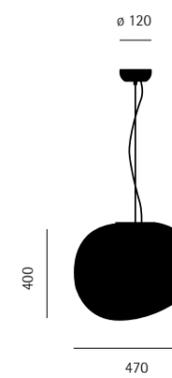

gregg piccola

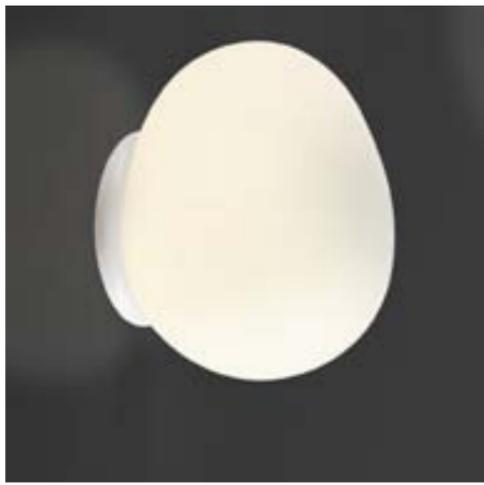

arandela applicada
material
vidro soprado
cor
bianco
fonte de luz
1x halógena G9
até 20W

uso interno
ip 20



gregg media



arandela applicada
material
vidro soprado
cor
bianco
fonte de luz
1x incandescente
leitosa E27
até 100W
1x fluorescente
compacta E27
até 73W

uso interno
ip 20

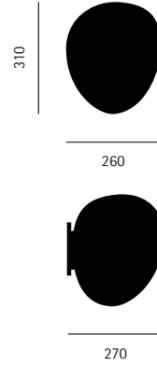

gregg piccola

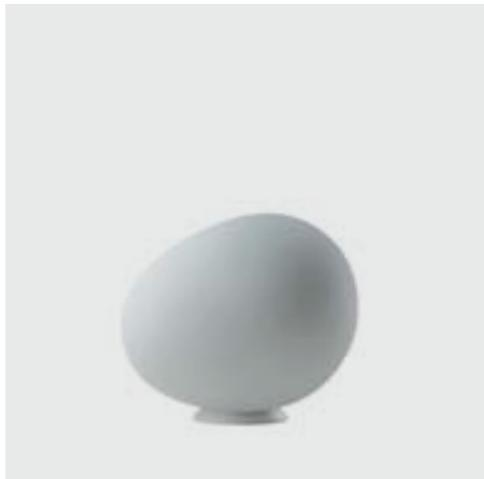

mesa
material
vidro soprado
cor
bianco
fonte de luz
1x halopin com
bulbo fosco G9
até 25W

uso interno
ip 20

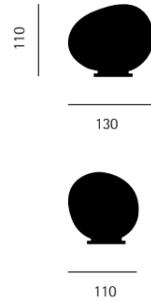

gregg media



mesa
material
vidro soprado
cor
bianco
fonte de luz
1x incandescente
leitosa E27
até 100W

uso interno
ip 20

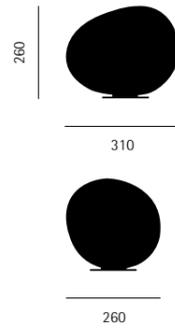

gregg grande



mesa
material
vidro soprado
cor
bianco
fonte de luz
1x incandescente
leitosa E27
até 100W
1x fluorescente
compacta eletrô-
nica até 70W
dimerizável

uso interno
ip 20

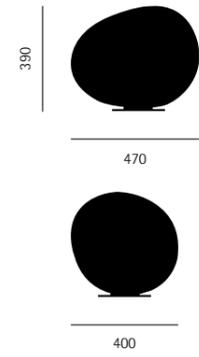

gregg media alta



piso
material
vidro soprado
cor
bianco
fonte de luz
1x incandescente
leitosa E27
até 100W
1x halógena E27
até 205W

uso interno
ip 20

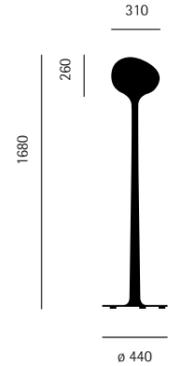

gregg grande alta



piso
material
vidro soprado
cor
bianco
fonte de luz
1x incandescente
leitosa E27
até 100W
1x halógena E27
até 205W

uso interno
ip 20

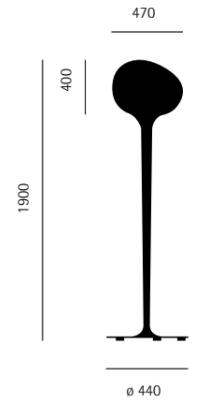

gregg media bassa



piso
material
vidro soprado
cor
bianco
fonte de luz
1x incandescente
leitosa E27
até 100W
1x halógena E27
até 205W

uso interno
ip 20

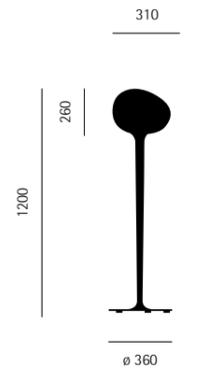

gregg grande bassa



piso

material
vidro soprado
cor
bianco
fonte de luz
1x incandescente
leitosa E27
até 100W
1x halógena E27
até 205W

uso interno
ip 20

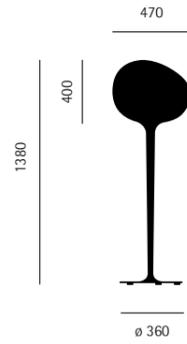

havana mono



piso

materiais
metal esmaltado
e polietileno
acetinado
cores
bianco, giallo
fonte de luz
1x halógena E27
até 46W
1x incandescente
leitosa E27
até 60W
1x fluorescente
compacta eletrô-
nica E27 até 12W

uso interno
externo
ip 65

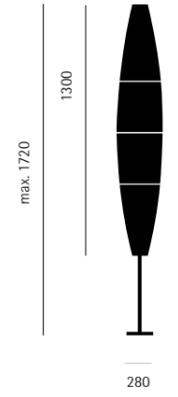

havana

design
jozeph forakis



hope

design
francisco gomez
paz
paolo rizzato



havana mono



pendente

materiais
metal esmaltado
e polietileno
acetinado
cores
bianco, giallo
fonte de luz
1x halógena E27
até 46W
1x incandescente
leitosa E27
até 60W
1x fluorescente
compacta eletrô-
nica E27 até 12W

uso interno
externo
ip 65

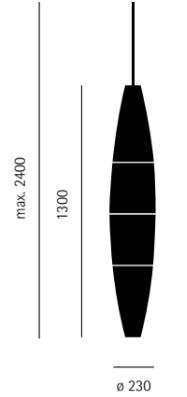

hope 8a



arandela

material
policarbonato
fresnel
cor
transparent
fonte de luz
1x incandescente
cristal E27
até 100W
1x halógena E27
até 105W

uso interno
ip 20

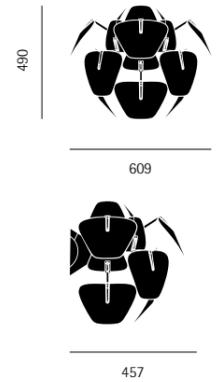

havana mono



arandela

materiais
metal esmaltado
e polietileno
acetinado
cores
bianco, giallo
fonte de luz
1x halógena E27
até 46W
1x incandescente
leitosa E27
até 60W
1x fluorescente
compacta eletrô-
nica E27 até 12W

uso interno
externo
ip 65

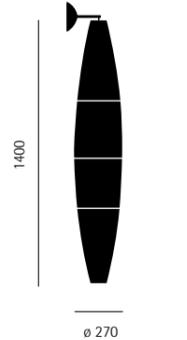

hope 12



pendente

material
policarbonato
fresnel
cor
transparent
fonte de luz
1x incandescente
cristal E27
até 100W
1x halógena E27
até 105W

uso interno
ip 20

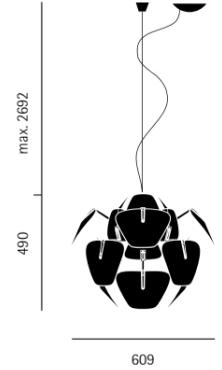

hope 18



pendente

material
policarbonato
fresnel
cor
transparent
fonte de luz
1x incandescente
cristal E27
até 100W
1x halógena E27
até 105W

uso interno
ip 20

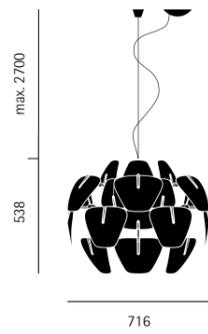

hope 42



pendente

material
policarbonato
fresnel
cor
transparent
fonte de luz
3x incandescente
cristal E27
até 100W
3x halógena E27
até 105W

uso interno
ip 20

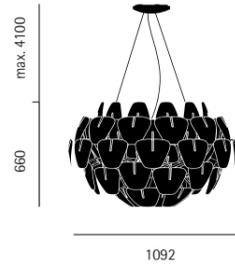

jieldé loft

design
jieldé



loft D6440



mesa

material
metal
cores
moutarde-1003,
ivoire-1015,
orange-2004,
bourgogne-3005,
rouge-3020,
rose-4003,
fushia-4008,
bleu-5012, bleu
pastel-5024, vert
olive-6003, vert
pomme-6018,
vert eau-6019,
kaki-7002,
chocolat-8017,
blanc, chrome,
noir-9011, acier
brossé

fonte de luz
1x incandescente
leitosa E27
até 100W

uso interno
ip 20

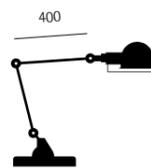

loft D1260



piso

material
metal
cores
moutarde-1003,
ivoire-1015,
orange-2004,
bourgogne-3005,
rouge-3020,
rose-4003,
fushia-4008,
bleu-5012, bleu
pastel-5024, vert
olive-6003, vert
pomme-6018,
vert eau-6019,
kaki-7002,
chocolat-8017,
blanc, chrome,
noir-9011, acier
brossé

fonte de luz
1x incandescente
leitosa E27
até 100W

uso interno
ip 20

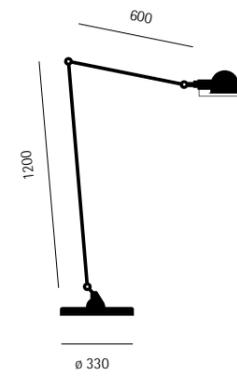

loft D9406



piso

material
metal
cores
moutarde-1003,
ivoire-1015,
orange-2004,
bourgogne-3005,
rouge-3020,
rose-4003,
fushia-4008,
bleu-5012, bleu
pastel-5024, vert
olive-6003, vert
pomme-6018,
vert eau-6019,
kaki-7002,
chocolat-8017,
blanc, chrome,
noir-9011, acier
brossé

fonte de luz
1x incandescente
leitosa E27
até 100W

uso interno
ip 20

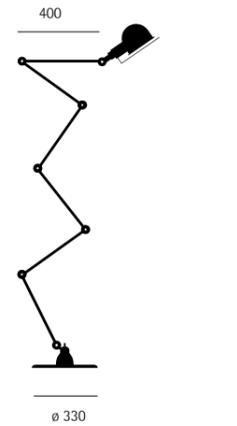

loft DD7460



piso

material
metal
cores
moutarde-1003,
ivoire-1015,
orange-2004,
bourgogne-3005,
rouge-3020,
rose-4003,
fushia-4008,
bleu-5012, bleu
pastel-5024, vert
olive-6003, vert
pomme-6018,
vert eau-6019,
kaki-7002,
chocolat-8017,
blanc, chrome,
noir-9011, acier
brossé

fonte de luz
2x incandescente
leitosa E27
até 100W

uso interno
ip 20

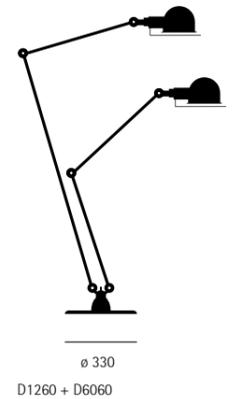



signal SI301



arandela

material
metal
cores
moutarde-1003,
ivoire-1015,
orange-2004,
bourgogne-3005,
rouge-3020,
rose-4003,
fushia-4008,
bleu-5012, bleu
pastel-5024, vert
olive-6003, vert
pomme-6018,
vert eau-6019,
kaki-7002,
chocolat-8017,
blanc, chrome,
noir-9011, acier
brossé

fonte de luz
1x incandescente
E14 até 40W

uso interno
ip 20

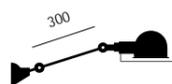

joy

design
fernando prado



signal SI833

piso

material
metal
cores
moutarde-1003,
ivoire-1015,
orange-2004,
bourgogne-3005,
rouge-3020,
rose-4003,
fushia-4008,
bleu-5012, bleu
pastel-5024, vert
olive-6003, vert
pomme-6018,
vert eau-6019,
kaki-7002,
chocolat-8017,
blanc, chrome,
noir-9011, acier
brossé

fonte de luz
1x incandescente
E14 até 40W

uso interno
ip 20

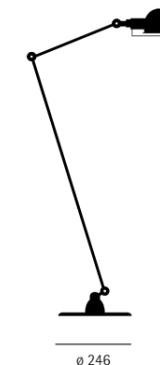

signal SI433



mesa

material
metal
cores
moutarde-1003,
ivoire-1015,
orange-2004,
bourgogne-3005,
rouge-3020,
rose-4003,
fushia-4008,
bleu-5012, bleu
pastel-5024, vert
olive-6003, vert
pomme-6018,
vert eau-6019,
kaki-7002,
chocolat-8017,
blanc, chrome,
noir-9011, acier
brossé

fonte de luz
1x incandescente
E14 até 40W

uso interno
ip 20

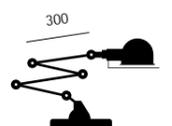

joy S



pendente

material
polipropileno
translúcido
cor
branco fosco
texturizado
fonte de luz
1x incandescente
leitosa E27
até 100W
1x halógena E27
até 70W

uso interno
ip 20

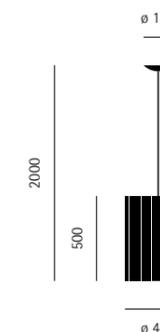

signal SI333



mesa

material
metal
cores
moutarde-1003,
ivoire-1015,
orange-2004,
bourgogne-3005,
rouge-3020,
rose-4003,
fushia-4008,
bleu-5012, bleu
pastel-5024, vert
olive-6003, vert
pomme-6018,
vert eau-6019,
kaki-7002,
chocolat-8017,
blanc, chrome,
noir-9011, acier
brossé

fonte de luz
1x incandescente
E14 até 40W

uso interno
ip 20

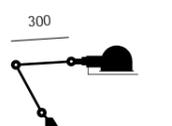

joy F



piso

materiais
polipropileno
translúcido e
alumínio
cor
branco fosco
texturizado
fonte de luz
1x incandescente
leitosa E27
até 100W
1x halógena E27
até 70W

uso interno
ip 20

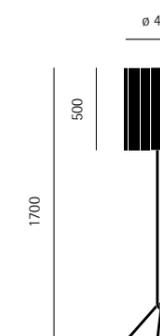

le soleil

design vicente garcia jimenez



pendente

material policarbonato
cores aquamarina, branco, rosso
fonte de luz 3x halopin com bulbo fosco G9 até 60W

uso interno ip 20

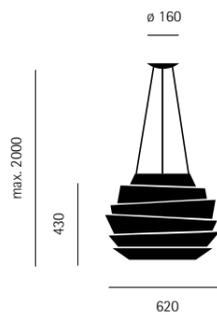

lift

design fernando prado



piso

materiais aço inox, alumínio e madeira
cores branco fosco texturizado, madeira, preto fosco texturizado
fonte de luz 1x incandescente leitosa E27 até 100W
1x halógena E27 até 70W

uso interno ip 20

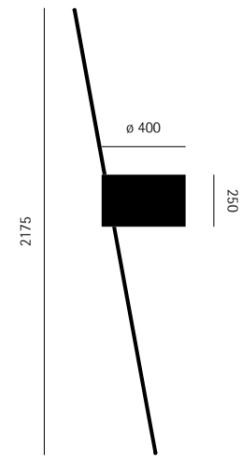

led it be

design fernando prado



lightweight

design tom dixon

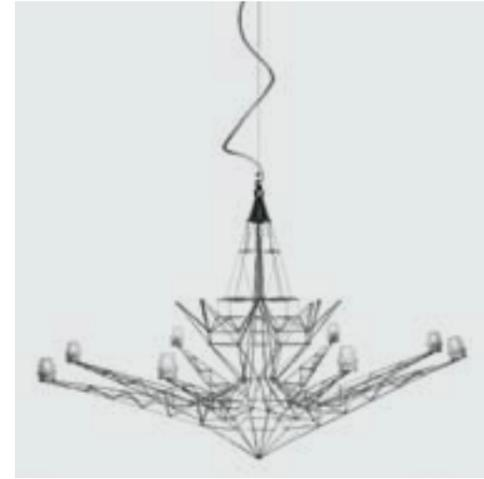

pendente

materiais metal anodizado e vidro soprado acetinado
fonte de luz 8x halógena bipino G4 12v até 25W

uso interno ip 20

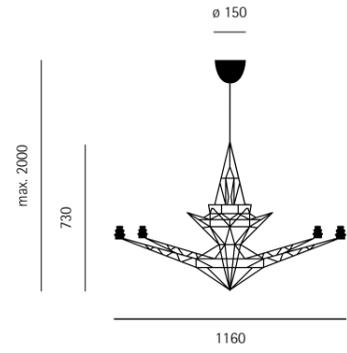

led it be B



arandela

material alumínio
cores branco fosco texturizado, grafite, preto, preto texturizado, titânio
fonte de luz 1x LED 1W warm white

uso interno ip 20



lumiere

design rodolfo dordoni



led it be T



mesa

material alumínio
cores branco fosco texturizado, grafite, preto, preto texturizado, titânio
fonte de luz 1x LED 1W warm white

uso interno ip 20

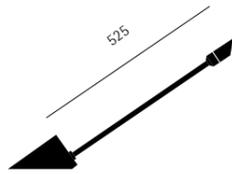

lumiere 05 piccola

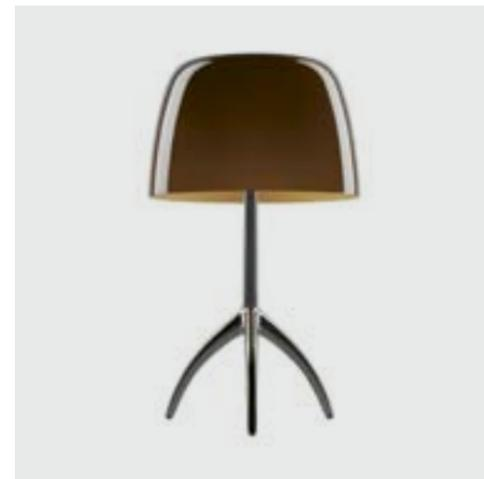

mesa

materiais alumínio e vidro soprado
cores ambra, avorio, branco
fonte de luz 1x incandescente E14 até 42W

uso interno ip 20

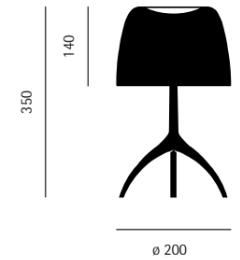

lumiere 05 grande



mesa
materiais
alumínio e vidro
soprado
cores
ambra, avorio,
branco
fonte de luz
3x incandescente
E14 até 30W

uso interno
ip 20

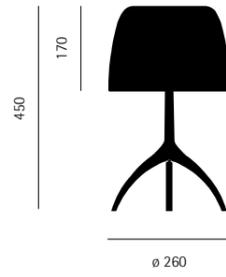

luna

design
fernando prado



lumiere XXS



mesa
materiais
alumínio e vidro
soprado
cores
branco/branco,
branco/nero,
bronzo/branco,
bronzo/nero
fonte de luz
1x halopin com
bulbo fosco G9
até 40W

uso interno
ip 20

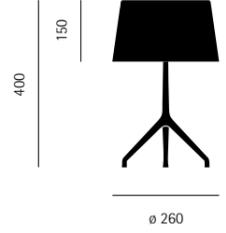

luna C



aplicada
materiais
alumínio
cores
branco fosco
texturizado, preto
fosco texturizado,
titânio
fonte de luz
2x halopin com
bulbo fosco G9
até 60W

uso interno
ip 20

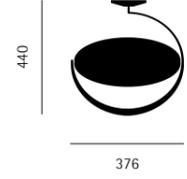

lumiere XXL



mesa
materiais
alumínio e vidro
soprado
cores
branco/branco,
branco/nero,
bronzo/branco,
bronzo/nero
fonte de luz
3x halopin com
bulbo fosco G9
até 60W

uso interno
ip 20

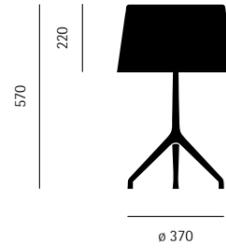

luna F



piso
materiais
alumínio
cores
branco fosco
texturizado, preto
fosco texturizado,
titânio
fonte de luz
2x halopin com
bulbo fosco G9
até 60W

uso interno
ip 20

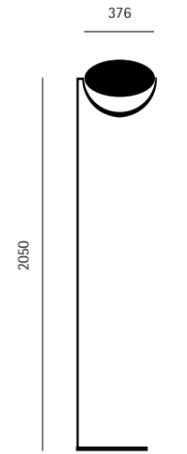

magneto

design
giulio iacchetti



piso
materiais
ABS e aço
envernizado
cor
grigio
fonte de luz
1x LED 2,4W
2700K

uso interno
ip 20

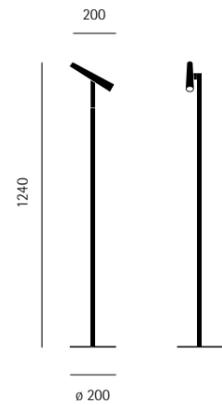

maki

design
nendo



pendente

materiais
aluminio laqueado
cor
branco
fonte de luz
1x halógena PAR
16 GU10 até 35W

uso interno
ip 20

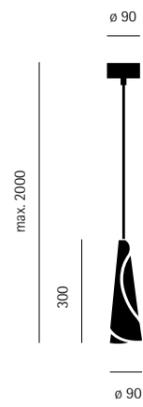

mirror ball 40cm



pendente

materiais
policarbonato
e aluminio
cor
chrome
fonte de luz
1x incandescente
leitosa E27
até 60W
1x halógena E27
até 42W

uso interno
ip 20



metropoli

design
paolo rizzato
alberto meda
riccardo sarfatti



arandela

materiais
aluminio fundido,
vidro e policarbonato
impermeável
fonte de luz
1x incandescente
leitosa E27
até 100W

uso interno,
externo
ip 65



mirror ball 50cm



pendente

materiais
policarbonato
e aluminio
cor
chrome
fonte de luz
1x incandescente
leitosa E27
até 60W
1x halógena E27
até 42W

uso interno
ip 20

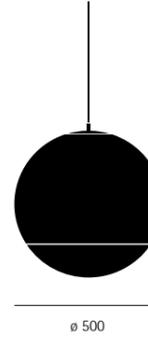

mirror ball

design
tom dixon



mirror ball 40cm



piso

materiais
policarbonato
e aluminio
cor
chrome
fonte de luz
1x incandescente
leitosa E27
até 60W

uso interno
ip 20



mirror ball 25cm



pendente

materiais
policarbonato
e aluminio
cor
chrome
fonte de luz
1x incandescente
leitosa E27
até 60W
1x halógena E27
até 42W

uso interno
ip 20



mirror ball 50cm



piso

materiais
policarbonato
e aluminio
cor
chrome
fonte de luz
1x incandescente
leitosa E27
até 60W

uso interno
ip 20



mirror ball tripod



piso

materiais
aço inoxidável,
policarbonato
e alumínio

cor
chrome

fonte de luz
1x incandescente
leitosa E27
até 60W

uso interno
ip 20

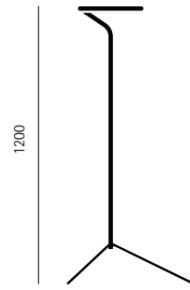

mite

design
marc sadler

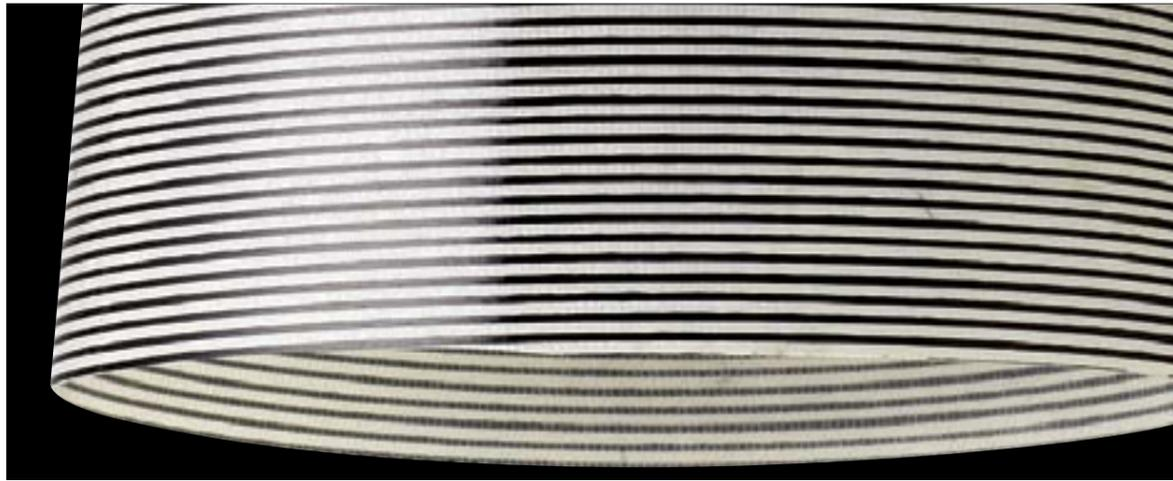

giga lite



pendente

materiais
aço inoxidável,
tecido de fibra
de vidro com fio
kevlar amarelo
ou fio de carbono

cores
giallo, nero

fonte de luz
3x incandescente
leitosa E27
até 100W
3x halógena E27
até 70W
3x fluorescente
compacta eletrô-
nica E27 até 20W

uso interno
ip 20

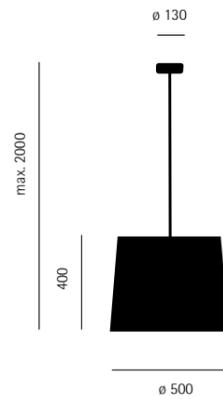

tite 1



pendente

materiais
aço inoxidável,
tecido de fibra
de vidro com fio
kevlar amarelo
ou fio de carbono

cores
giallo, nero

fonte de luz
1x fluorescente
compacta eletrô-
nica E27 até 23W
1x incandescente
leitosa até 100W

uso interno
ip 20



tite 2



pendente

materiais
aço inoxidável,
tecido de fibra
de vidro com fio
kevlar amarelo
ou fio de carbono

cores
giallo, nero

fonte de luz
1x fluorescente
compacta eletrô-
nica E27 até 23W
1x incandescente
leitosa até 100W

uso interno
ip 20

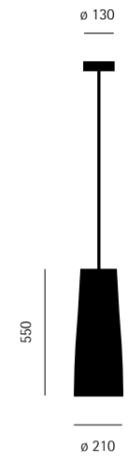

tite 3



pendente

materiais
aço inoxidável,
tecido de fibra
de vidro com fio
kevlar amarelo
ou fio de carbono

cores
giallo, nero

fonte de luz
1x fluorescente
compacta eletrô-
nica E27 até 20W
1x incandescente
leitosa até 100W

uso interno
ip 20

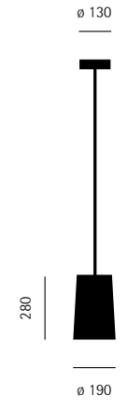

mini kite



arandela

materiais
tecido de fibra
de vidro com fio
kevlar amarelo
ou fio de carbono

cores
giallo, nero

fonte de luz
1x incandescente
E14 até 30W

uso interno
ip 20

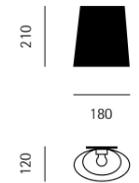

kite



arandela

materiais
tecido de fibra
de vidro com fio
kevlar amarelo
ou fio de carbono

cores
giallo, nero

fonte de luz
3x incandescente
E14 até 30W

uso interno
ip 20

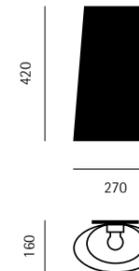

lite piccola



mesa

materiais
metal cromado,
tecido de fibra
de vidro com fio
kevlar amarelo
ou fio de carbono
cores
giallo, nero
fonte de luz
1x halógena E27
até 40W
1x incandescente
leitosa E27
até 60W

uso interno
ip 20

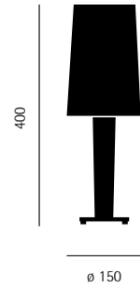

o-space

design
luca nichetto
giampietro gai



pendente

materiais
metal cromado
e poliuretano
expandido
cores
arancio, bianco
fonte de luz
1x halógena palito
R7s até 200W

uso interno
ip 20

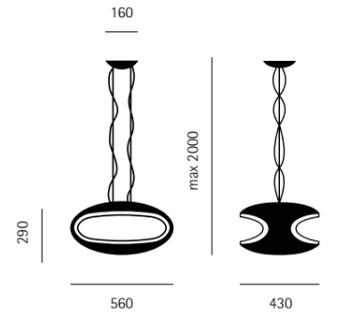

lite grande



mesa

materiais
metal cromado,
tecido de fibra
de vidro com fio
kevlar amarelo
ou fio de carbono
cores
giallo, nero
fonte de luz
1x halógena E27
até 70W
1x incandescente
leitosa E27
até 100W
1x fluorescente
compacta eletrô-
nica E27 até 20W

uso interno
ip 20

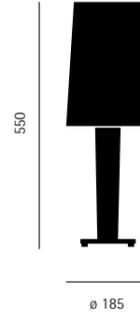

ovalle T

design
fernando prado



mesa

materiais
vidro opalino, aço
inox e madeira
cor
branco fosco
texturizado
fonte de luz
1x incandescente
leitosa E27
até 60W
1x halógena E27
até 70W

uso interno
ip 20

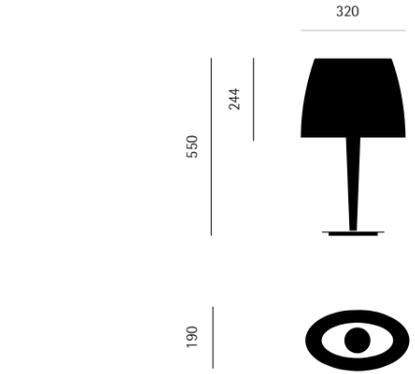

giga lite



piso

materiais
aço inoxidável,
tecido de fibra
de vidro com fio
kevlar amarelo
ou fio de carbono
cores
giallo, nero
fonte de luz
3x incandescente
leitosa E27
até 100W
3x halógena E27
até 116W

uso interno
ip 20

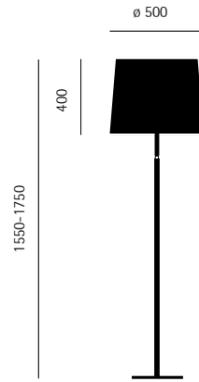

pett

design
diesel



mesa

materiais
policarbonato
e metal
cores
azzurro, fucsia
fonte de luz
1x fluorescente
compacta eletrô-
nica E14 até 12W

uso interno
ip 20

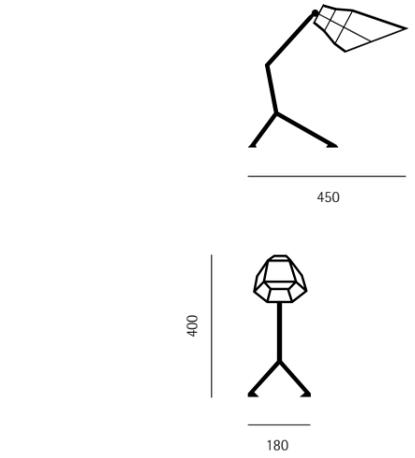

mite



piso

materiais
metal cromado,
tecido de fibra
de vidro com fio
kevlar amarelo
ou fio de carbono
cores
giallo, nero
fonte de luz
1x incandescente
leitosa E27
até 100W
1x halógena E27
até 150W

uso interno
ip 20

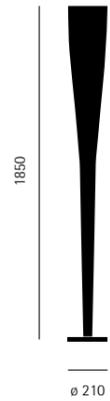



piccolo S



pendente

materiais
alumínio, vidro opalino soprado e alumínio escovado
cores
branco fosco texturizado
fonte de luz
1x halopin com bulbo fosco G9 até 40W

uso interno
ip 20

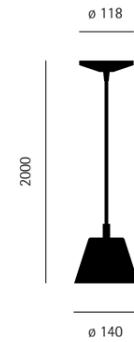

piccolo W



arandela

materiais
alumínio, vidro opalino soprado e alumínio escovado
cores
branco fosco texturizado
fonte de luz
1x halopin com bulbo fosco G9 até 40W

uso interno
ip 20

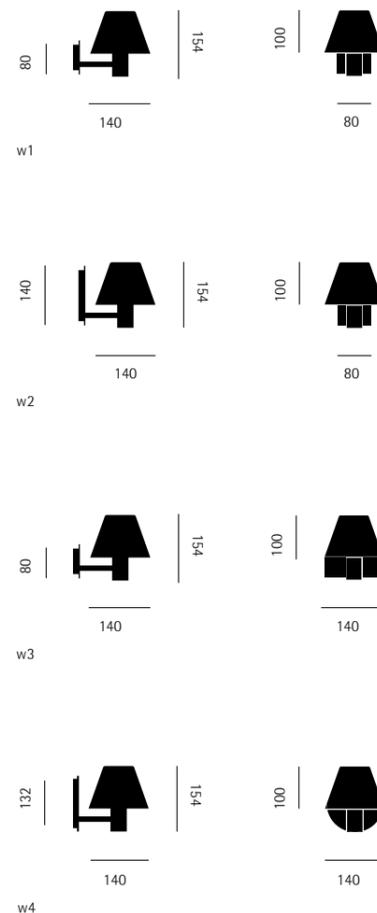

piccolo R



mesa

materiais
alumínio e pintura eletrostática
cores
azul claro, azul marinho, azul turquesa, branco fosco texturizado, fúcsia, grafite, laranja, mostarda, preto fosco texturizado, rosa, titânio, verde claro, verde médio, verde oliva, vermelho

fonte de luz
1x halopin com bulbo fosco G9 até 40W
uso interno
ip 20

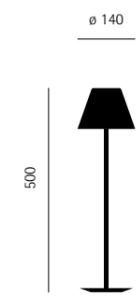

piccolo T



mesa

materiais
alumínio, vidro opalino soprado e alumínio escovado
cores
branco fosco texturizado
fonte de luz
1x halopin com bulbo fosco G9 até 60W

uso interno
ip 20

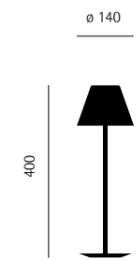

piccolo F



piso

materiais
alumínio, vidro opalino soprado e alumínio escovado
cores
branco fosco texturizado
fonte de luz
1x halopin com bulbo fosco G9 até 40W

uso interno
ip 20

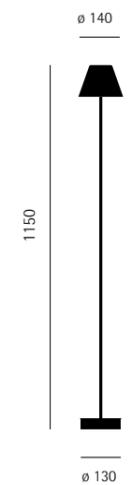

pipe

design
diesel



pixell

design
fabio falanghe

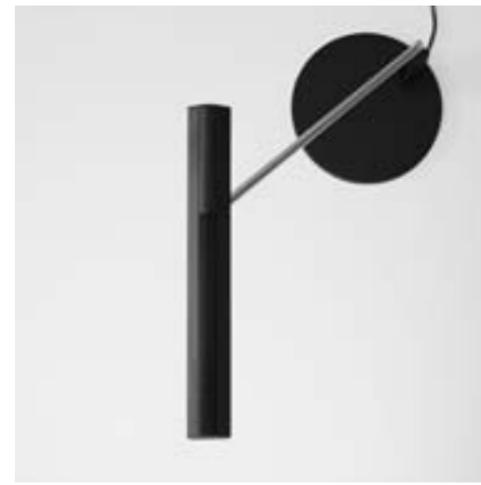

mesa

material
aluminio
cores
branco fosco
texturizado,
grafite, preto
fosco texturizado,
titânio
fonte de luz
1x LED 8W
warm white

uso interno
ip 20

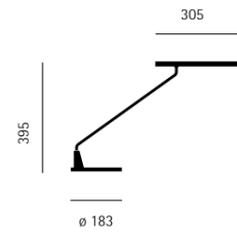

pipe



mesa

materiais
metal e tecido
cores
branco, nero
fonte de luz
1x fluorescente
compacta eletrô-
nica E27 até 20W

uso interno
ip 20

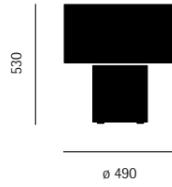

planet

design
changedesign

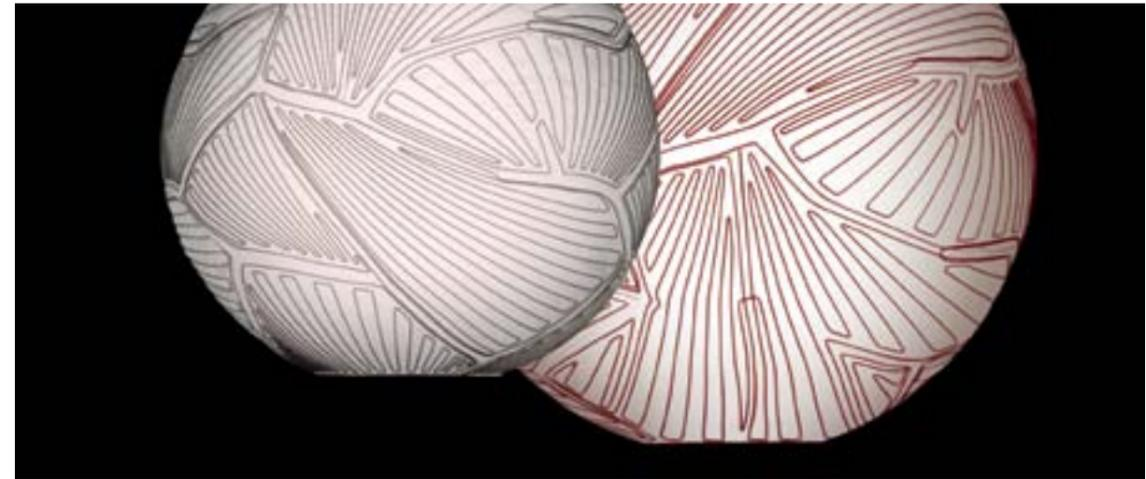

pipe



piso

materiais
metal e tecido
cores
branco, nero
fonte de luz
2x fluorescente
compacta eletrô-
nica E27 até 20W
2x incandescente
leitosa E27
até 100W

uso interno
ip 20

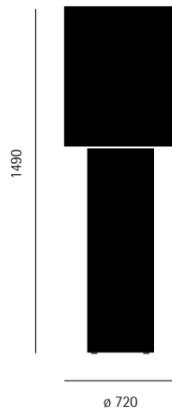

planet
piccola



pendente

material
tecido
cores
branco/bianco,
branco/rosso,
rosso/rosso
fonte de luz
1x incandescente
leitosa E27
até 100W
1x halógena E27
até 105W

uso interno
ip 20

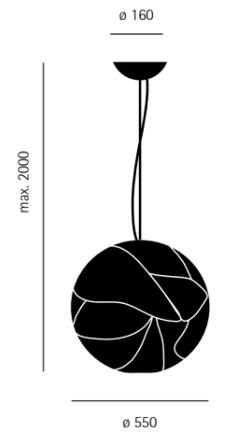

pipe
light

design
tom dixon



pendente

material
alumínio extru-
dado
cores
black/gold,
white/pink
fonte de luz
1x incandescente
leitosa E27
até 100W
1x halógena E27
até 100W

uso interno
ip 20

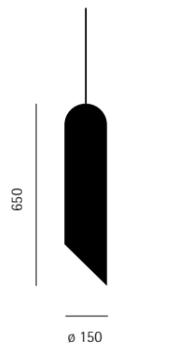

planet
grande



pendente

material
tecido
cores
branco/bianco,
branco/rosso,
rosso/rosso
fonte de luz
1x halógena E27
até 150W
1x incandescente
leitosa E27
até 100W

uso interno
ip 20

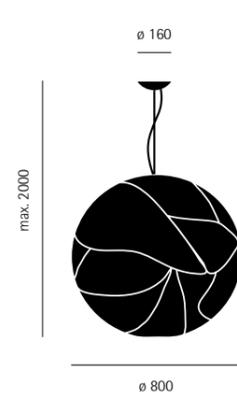

plissé

design
inga sempé

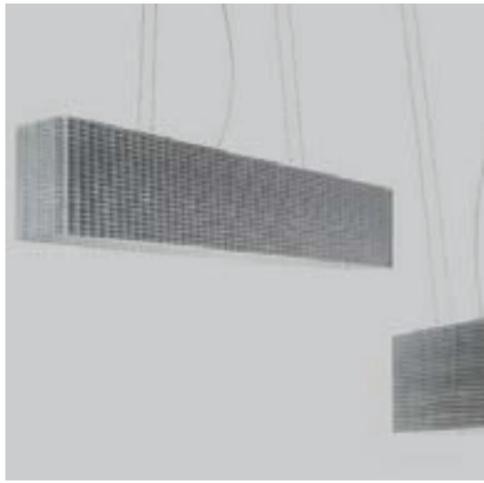

pendente

materiais
aço, alumínio
e poliéster
cor
white
fonte de luz
7x incandescente
E14 até 60W

uso interno
ip 20

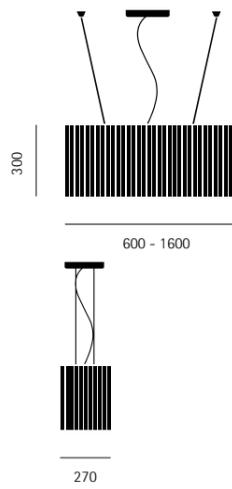

quadratta

design
fernando prado



pendente

materiais
alumínio
cor
branco fosco
texturizado
fonte de luz
1x halógena palito
R7s até 300W

uso interno
ip 20

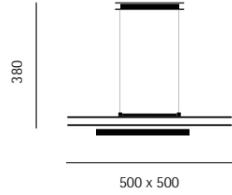

rock



piso

materiais
policarbonato
esmaltado
cores
branco, nero
fonte de luz
1x fluorescente
compacta eletrô-
nica E27 até 23W

uso interno
ip 20

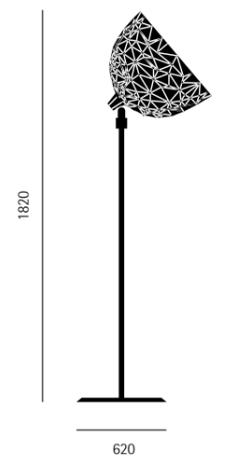

secto

design
seppo koho



rock

design
diesel



pendente

materiais
policarbonato
esmaltado
cores
branco, nero
fonte de luz
1x fluorescente
compacta eletrô-
nica E27 até 23W

uso interno
ip 20

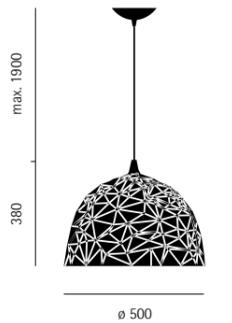

secto 4200



pendente

materiais
madeira de bétula
cores
black, birch,
walnut, white
fonte de luz
1x incandescente
leitosa E27
até 60W
1x fluorescente
compacta E27
até 18W

uso interno
ip 20

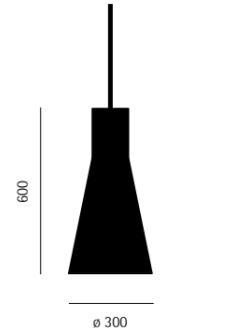

secto 4201



pendente

materiais
madeira de bétula
cores
black, birch,
walnut, white
fonte de luz
1x incandescente
leitosa E27
até 60W
1x fluorescente
compacta E27
até 18W

uso interno
ip 20

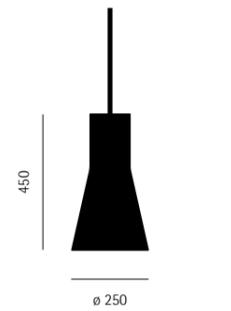

rock



solar outdoor

design
jean marie
massaud



pisso
material
polietileno
cor
legno nero
fonte de luz
1x fluorescente
compacta eletrônica E27 até 25W

uso externo
ip 44

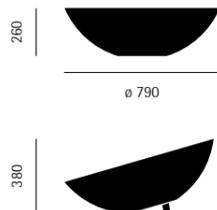

theodora

design
fernando prado



pendente
materiais
vidro opalino
e vidro transparente
cor
branco fosco
texturizado
fonte de luz
1x incandescente
leitosa E27 até 100W
1x halógena E27 até 70W

uso interno
ip 20

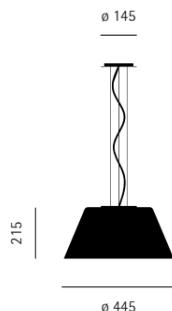

trama

design
paola longhi
luciano balestrini

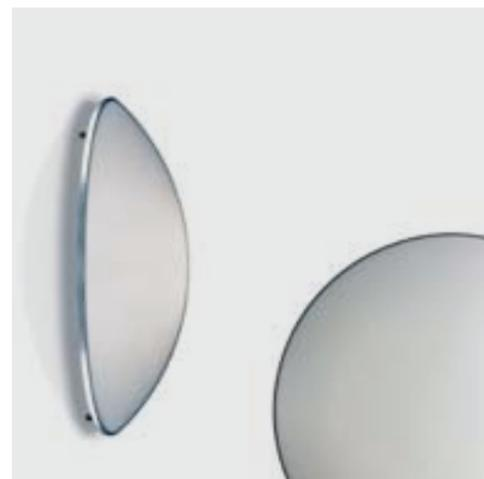

arandela aplicada
material
policarbonato
cor
branco
fonte de luz
3x incandescente
leitosa E27 até 100W
3x fluorescente
compacta eletrônica E27 até 23W

uso interno
ip 20

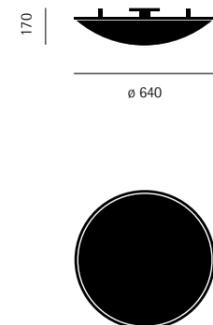

secto 4220



mesa
material
madeira de bétula
cores
black, birch,
walnut, white
fonte de luz
1x incandescente
leitosa E27 até 60W
1x fluorescente
compacta E27 até 18W

uso interno
ip 20

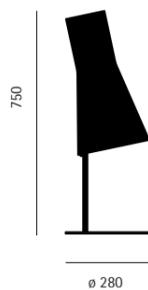

tool

design
diesel



tool pequena



pendente
material
borracha
cor
nero
fonte de luz
1x halógena PAR
16 GU10 até 35W

uso interno
ip 20

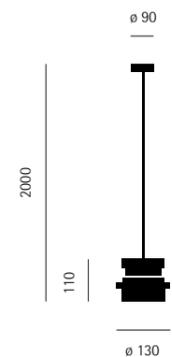

tool grande

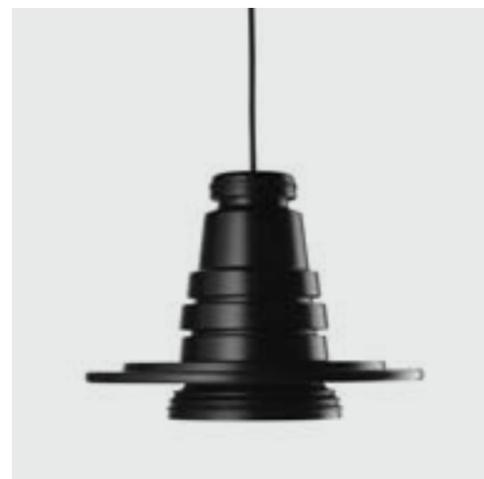

pendente
material
borracha
cor
nero
fonte de luz
1x halopin
com bulbo fosco
G9 até 60W

uso interno
ip 20

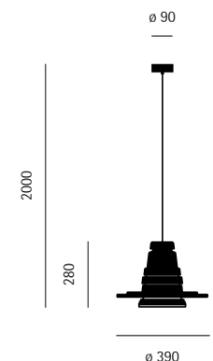



tress mini



pendente

material
fibra de vidro
laqueada
cores
bianco, nero
fonte de luz
1x halógena PAR
16 E27 até 50W

uso interno
ip 20

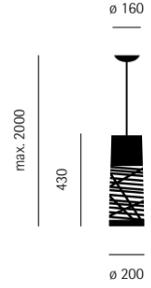

tress media



pendente

material
fibra de vidro
laqueada
cores
bianco, nero
fonte de luz
1x halógena PAR
30 E27 até 100W

uso interno
ip 20

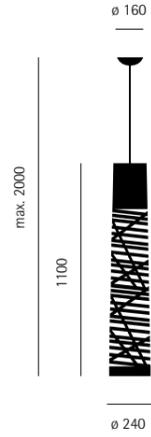

tress grande



pendente

material
fibra de vidro
laqueada
cores
bianco, nero
fonte de luz
1x halógena palito
R7s até 230W

uso interno
ip 20

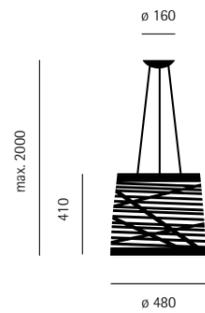

tress piccola



arandela

material
fibra de vidro
laqueada
cor
bianco, nero,
rosso
fonte de luz
1x halógena palito
R7s até 120W

uso interno
ip 20



tress grande



arandela

material
fibra de vidro
laqueada
cor
bianco, nero,
rosso
fonte de luz
1x halógena palito
R7s até 120W

uso interno
ip 20

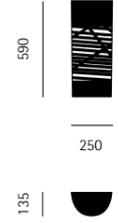

tress grande



piso

material
fibra de vidro
laqueada
cores
bianco, nero,
rosso
fonte de luz
1x halógena palito
R7s até 230W

uso interno
ip 20

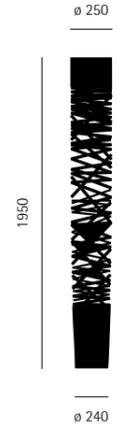

tri-p

design
diesel



piso

material
tecido elástico
e metal anodizado
cores
bianco, blu
fonte de luz
1x fluorescente
compacta eletrô-
nica E27 até 30W

uso interno
ip 20

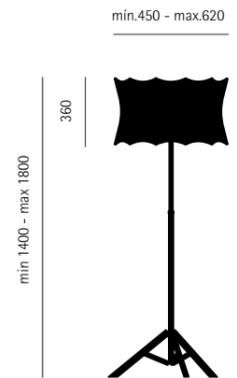

tua

design
marco zito



mesa

material
aluminio
cor
bianco
fonte de luz
1x halopin bulbo
fosco até 40W

uso interno
ip 20

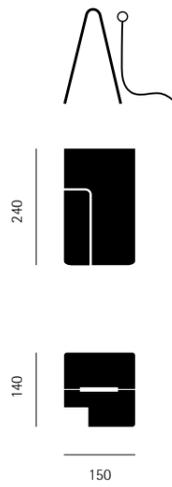

twiggy



mesa

material
fibra de vidro
laqueada
cores
branco, giallo,
nero, rosso
fonte de luz
1x halopin com
bulbo fosco G9
até 60W

uso interno
ip 20

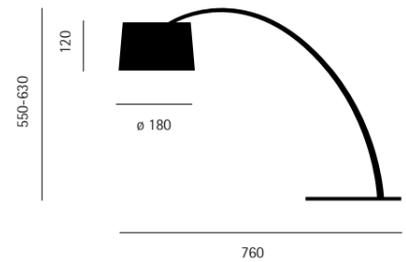

twiggy

design
marc sadler

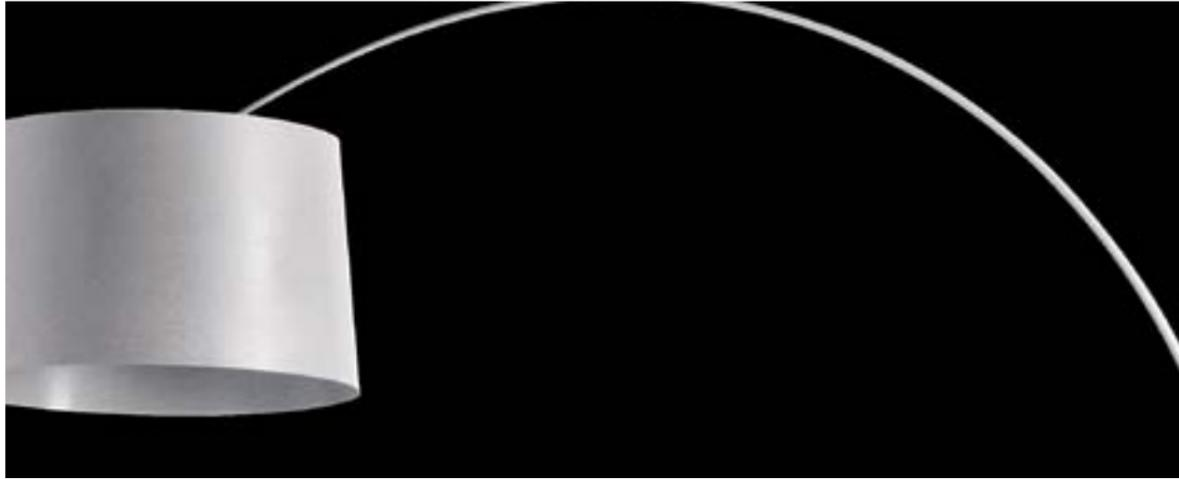

twiggy



piso

material
fibra de vidro
laqueada
cores
branco, giallo,
nero, rosso
fonte de luz
1x fluorescente
compacta eletrô-
nica E27 até 20W
3x incandescente
leitosa E27
até 100W

uso interno
ip 20

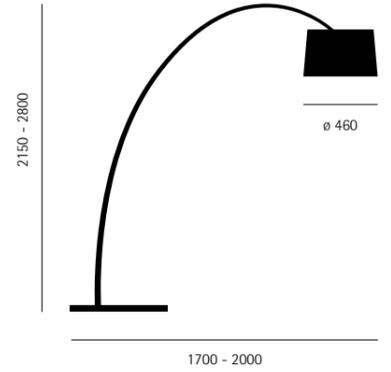

twiggy



pendente

material
fibra de vidro
laqueada
cores
branco, giallo,
nero, rosso
fonte de luz
3x fluorescente
compacta eletrô-
nica E27 até 20W
3x incandescente
leitosa E27
até 100W

uso interno
ip 20

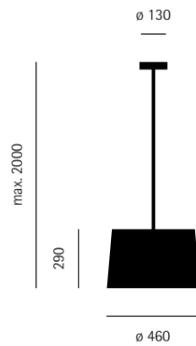

twiggy
leitura



piso

material
fibra de vidro
laqueada
cores
branco, giallo,
nero, rosso
fonte de luz
3x fluorescente
compacta eletrô-
nica E27 até 20W
3x incandescente
leitosa E27
até 100W

uso interno
ip 20

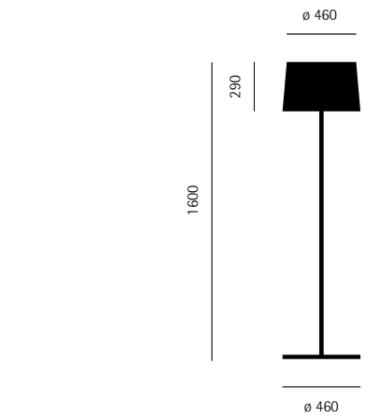

twiggy

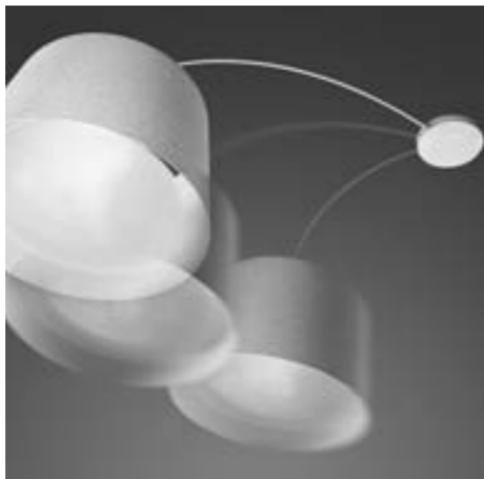

aplicada

material
fibra de vidro
laqueada
cores
branco, giallo,
nero, rosso
fonte de luz
3x fluorescente
compacta eletrô-
nica E27 até 20W
3x incandescente
leitosa E27
até 100W

uso interno
ip 20

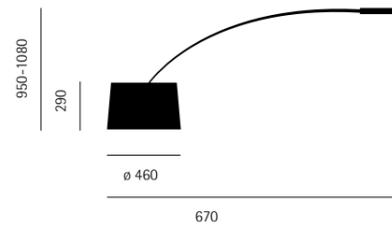

uto

design
lagranja



pendente
mesa
piso

materiais
policarbonato
e silicone
cores
arancio, branco,
giallo
fonte de luz
1x incandescente
leitosa E27
até 40W
1x fluorescente
compacta eletrô-
nica E27 até 12W

uso interno,
externo
ip 44

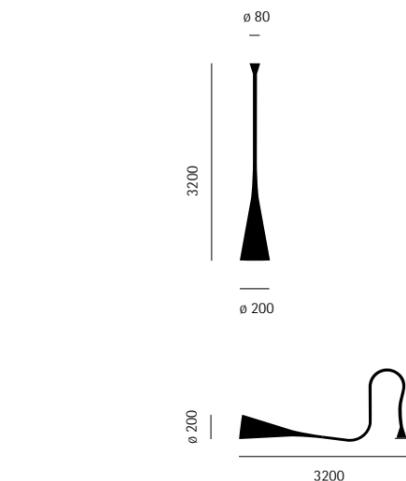

vinte2

design fernando prado



wave

design studio baruffi & de santi

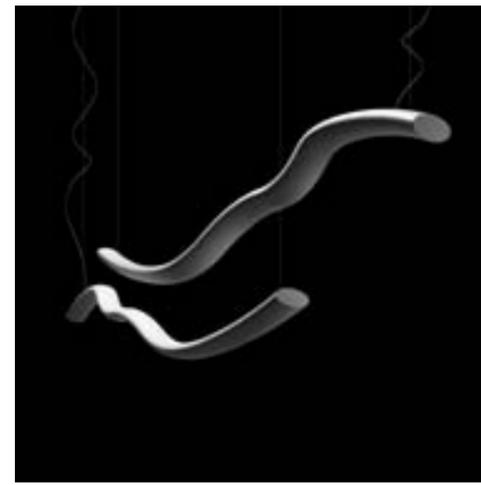

pendente
material alumínio laqueado
cores alu, branco, nero
fonte de luz 3x halógena palito R7s até 80W
uso interno ip 20

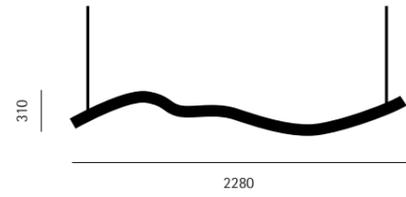

vinte2



pendente

materiais madeira freijó e alumínio
cores azul claro, azul marinho, azul turquesa, branco fosco texturizado, fúcsia, grafite, laranja, mostarda, preto fosco texturizado, rosa, titânio, verde claro, verde médio, verde oliva, vermelho

fonte de luz 1x incandescente leitosa E27 até 100W
1x halógena E27 até 70W

uso interno ip 20

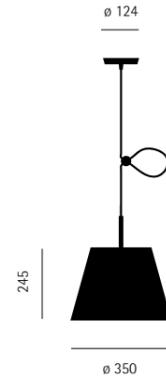

wish

design fernando prado



vinte2



mesa

materiais madeira freijó e alumínio
cores azul claro, azul marinho, azul turquesa, branco fosco texturizado, fúcsia, grafite, laranja, mostarda, preto fosco texturizado, rosa, titânio, verde claro, verde médio, verde oliva, vermelho

fonte de luz 1x incandescente leitosa E27 até 100W
1x halógena E27 até 70W

uso interno ip 20

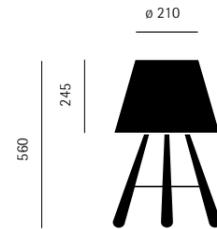

wish S



pendente

materiais alumínio escovado e tecido
cores branco liso, preto, vermelho
fonte de luz 1x incandescente leitosa E27 até 100W
1x halógena E27 até 70W

uso interno ip 20

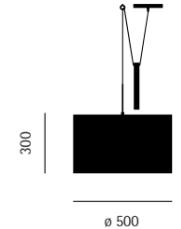

void light

design tom dixon



pendente

materiais aço inoxidável, bronze ou cobre
cores copper, brass, silver
fonte de luz 1x halopin com bulbo fosco G9 até 25W

uso interno ip 20

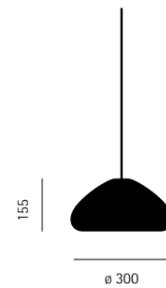

wish S40



pendente

materiais alumínio escovado e tecido
cores branco liso, preto, vermelho
fonte de luz 1x incandescente leitosa E27 até 100W
1x halógena E27 até 70W

uso interno ip 20

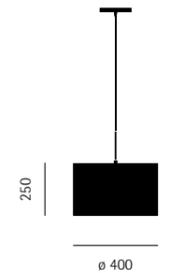

wish T



mesa

materiais
alumínio escovado e tecido
cores
branco liso, preto, vermelho
fonte de luz
1x incandescente leitosa E27 até 100W
1x halógena E27 até 70W

uso interno
ip 20

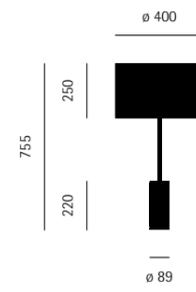

wish F



piso

materiais
alumínio escovado e tecido
cores
branco liso, preto, vermelho
fonte de luz
1x incandescente leitosa E27 até 100W
1x halógena E27 até 70W

uso interno
ip 20

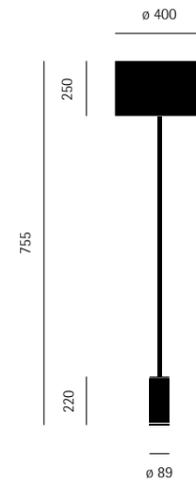

índice remissivo

	pendente	arandelas	aplicadas	mesa	piso	especificações
360°	50					296
allegro+allegretto	52					296
anisha				172		298
aplomb	54					298
atollo				173		299
baju				174		299
base light		130		175	244	299
barovier&ttoso						300
bauhaus 90		146		218	245	304
beat	56					305
behive				176		306
berenice		148		222	250	307
big bang	58					308
bill				224		308
binic				178		309
birdie				182	251	309
blow			158			313
bocci 14	62	131	159			310
bocci 28	63					312
bossa	66					313
bridge					254	314
caboche	70	132	160			315
cage	74			184	255	317
carrara					256	318
chouchin	75					319
copper shade	76					320
costanza	78			185	258	321
costanzina	79	133		186		323
duii		149		226		324
eclipse		134				325
esa				187		326
etch shade	80					326
fat spot					259	320
fina					260	327
fool				188		327
fork	82			192	261	328
fortebraccio		150		227	262	329
giga lite					263	348
ginga				228		330
glas	83			193		331
glassglass	84	151	161			332
gregg	85	136		194	264	333
havana	86	137			265	336

	pendente	arandelas	aplicadas	mesa	piso	especificações
hope	87	138				337
jieldé loft				232	268	338
jieldé signal		152		233	269	340
joy	90				270	341
kite		139				348
le soleil	92					342
led it be		153		234		342
lift					271	343
lightweight	94					343
lite				198		348
lumiere				196		343
luna			162		274	345
magneto					278	345
maki	95					346
metropoli		140	164			346
mirror ball	96				279	346
mite					280	348
o-space	97					351
ovalle T				198		351
pett				236		351
piccolo	100	141		199	282	352
pipe				204	283	354
pipe light	101					354
pixell				237		355
planet	102					355
plissé	103					356
quadratta	104					356
rock	105				284	356
secto	106			205		357
solar outdoor					285	358
theodora	108					358
tite	109					348
tool	110					359
trama		142	165			359
tress	111	143			286	360
tri-p					287	361
tua				206		362
twiggy	114		166	240	288	362
uto	115				292	363
vinte2	116			207		364
void light	120					364
wave	121					365
wish	124			212	293	365