



mmdesign
illuminamente

Il nuovo catalogo MM Lampadari _ MM Design, edizione di stampa Giugno 2019, racchiude in sé, corretta ed aggiornata, ogni altra pubblicazione realizzata in passato. Sostituisce ed annulla, quindi, qualsiasi edizione precedente.

Uno strumento approfondito nei contenuti, dove trovate la panoramica di ciò che è tuttora in produzione, oltre naturalmente a tutte le più recenti novità.

La leggibilità inoltre è stata migliorata aggiungendo alla fine di ogni famiglia di prodotto le informazioni più importanti, in modo da rendere il catalogo un efficiente e più rapido strumento di consultazione.

Il nostro obiettivo è, giorno dopo giorno, potervi offrire l'esperienza di entrare sempre più nel nostro modo di pensare la luce.

The new catalogue, MM Lampadari _ MM Design, June 2019 print edition, contains in itself, corrected and updated, any other publication made in the past. It therefore replaces and cancels any previous edition.

An in-depth tool in the contents, where you can find an overview of what is still in production, as well as of course all the latest news.

Readability has also been improved by adding the most important information at the end of each product family, to make the catalogue an efficient and faster reference tool.

Our goal is, day after day, to be able to offer you the experience of entering more and more into our way of thinking about light.

MOLTO MEGLIO CON MM

Più di mezzo secolo di storia, abilità artigiana, conoscenza tecnica e visione estetica. Così completiamo l'anima delle nostre creazioni con la scelta di mantenere la nostra natura artigiana e legata al territorio.

MM Lampadari dimostra di essere un'azienda adattabile, con il forte obiettivo del design in continuo sviluppo. Vogliamo essere un punto di riferimento per l'immaginazione, il design e la diffusione della cultura dell'illuminazione. Sempre alla ricerca di soluzioni innovative attraverso il processo tecnologico e l'applicazione della luce ad alta tecnologia possiamo garantire valore in termini di prodotto, servizio, assistenza, flessibilità, risultati e ricerca tecnologica. All'eccellenza abbiamo aggiunto la qualità delle materie prime, senza mezzi termini. Per i modelli più esclusivi, selezioniamo infatti materiali di

alta gamma da abbinare a cristalli macinati a mano, applicazioni di strass e tessuti preziosi.

Tutto questo è possibile perché le nostre creazioni sono state realizzate e progettate nel nostro laboratorio in collaborazione con i nostri partner storici e qualificati, avendo il controllo di tutti i processi e la filiera produttiva. Ogni prodotto è testato, altra garanzia in termini di affidabilità, qualità e stile, nel rispetto delle persone e degli ambienti.

L'anima della luce prende forma nel prodotto proposto da MM Lampadari, grazie alla cura dei dettagli, agli aspetti funzionali ed estetici e al perfetto equilibrio tra innovazione, tecnologia e creatività.

Tradizione ed esperienza diventano una vera e propria espressione del "Made in Italy", il valore unico e senza tempo del design italiano.

MUCH BETTER WITH MM

More than half a century of history, craftsmanship, technical knowledge and aesthetic vision. In this way, we complete the soul of our creations with the choice of maintaining our artisan nature and linked to the territory.

MM Lampadari proves to be an adaptable company, with the strong objective of design in continuous development. We want to be a point of reference for the imagination, the design and the diffusion of the lighting culture. Always looking for innovative solutions through the technological process and the application of high-tech light, we can guarantee value in terms of product, service, assistance, flexibility, results and technological research. To excellence, we have added the quality of raw materials, in no uncertain terms. For the most exclusive models, we

select high-end materials to combine with hand-ground crystals, rhinestone applications and precious fabrics. All this is possible because our creations have been made and designed in our laboratory in collaboration with our historical and qualified partners, having control of all processes and the production chain. We test each product, another guarantee in terms of reliability, quality and style while respecting people and the environment.

The soul of light takes shape in the product proposed by MM Lampadari, thanks to the attention to detail, functional and aesthetic aspects and the perfect balance between innovation, technology and creativity.

Tradition and experience become a true expression of "Made in Italy" the unique and timeless value of Italian design.

TABLE OF CONTENTS

Arabesque	104
Arch	118
<i>NEW</i> Aria	30
Balloon	184
Balloton	146
Cage	202
Chill	164
Clessidra	80
Cloud	196
<i>NEW</i> Code	74
Dots	176
Fili	222
<i>NEW</i> Jack	66
<i>NEW</i> Kingdom	48
Leaf	92
Moonlight	112
Papillon	170
<i>NEW</i> Paramount	38
<i>NEW</i> Petal	22
Pill	136
Pineapple	190
<i>NEW</i> Rain	56
Rays	158
<i>NEW</i> Sass	212
Scarabocchio	218
Silvestro	230
<i>NEW</i> Sky	206
Trimming	236
<i>NEW</i> Whale	16
<i>NEW</i> Zoe	8



ZOE

CHIARA ANDREATTI
STUDIO SALARIS

Ispirata alle gloriose lampade dell'Art Decò ne adotta gli stilemi con una rilettura dal sapore contemporaneo. Elemento cardine del progetto è il cavo elettrico, parte essenziale del linguaggio estetico del progetto. Un elemento regolabile che consente di variarne le linee grafiche e l'aspetto formale. Struttura in metallo verniciato colore carbon black, globi in vetro fumè rosato.

Inspired by the glorious lamps of Art Deco, it adopts their stylistic features with a contemporary reinterpretation. The key element of the project is the electric cable, an essential part of the aesthetic language of the project. An adjustable element that allows to vary the graphic lines and the formal appearance. Structure in carbon black painted metal, globes in smoked pink glass.

7383/A4





7383/4S



7383/A2



7383/3

ZOE

Lampadina
Light bulb

28W eco E14
Classic P45



Metallo
Metal

V0199
Nero opaco
Matt black



Vetro
Glass

Vetro cipria
Blush pink glass



Art. 7383/A2

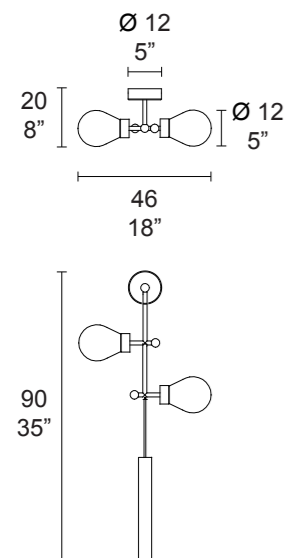

Art. 7383/A4

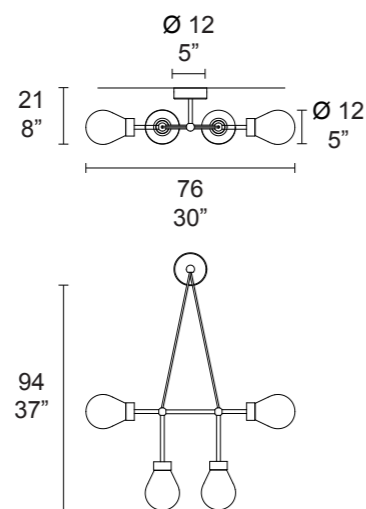

Art. 7383/4L

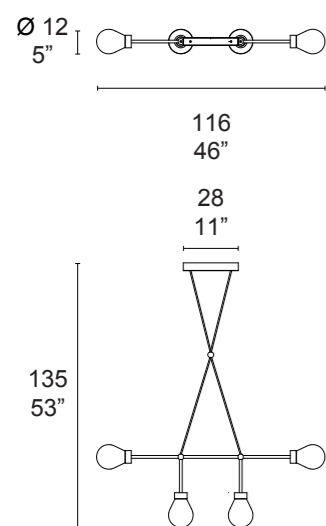

Art. 7383/4S

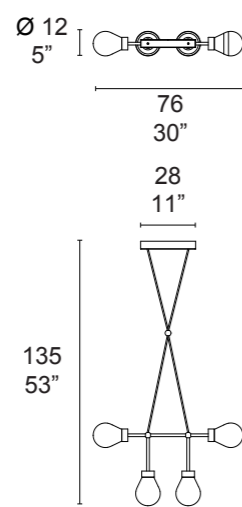

Art. 7383/3

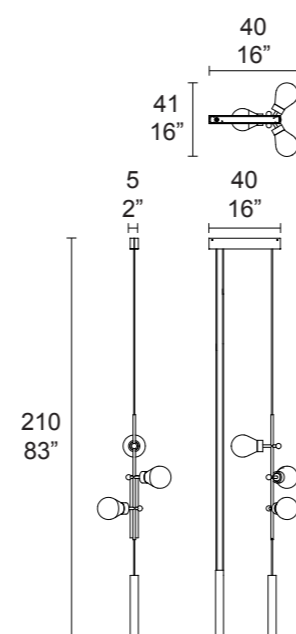

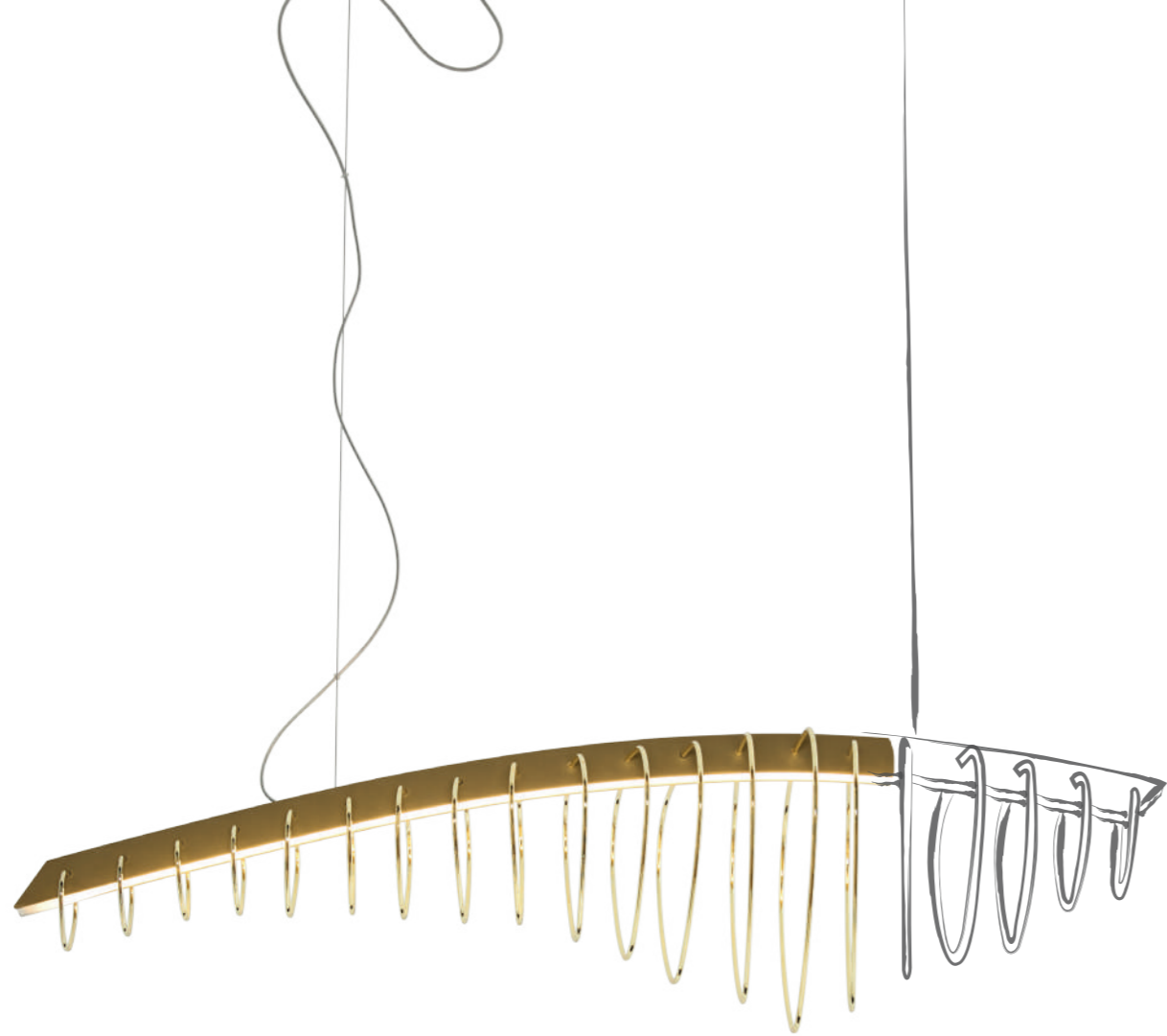

WHALE

LEO DE CARLO
MIST

Whale rappresenta il gesto di trasformare un simbolo della potenza naturale come una balena in qualcosa di rassicurante e utile: il tentativo di addomesticare la forma naturale attraverso la tecnica per ricordarci che comunque, nella profondità dei nostri cuori, è la natura l'elemento che ci sovrasta, ci ispira e ci guida.

Whale represents the gesture of transforming a symbol of natural power as a whale into something reassuring and useful: anyway, the attempt to domesticate the natural form through the technique to remind us that, in the depths of our hearts, is nature the element that dominates us, inspires us and guides us.

7378/2



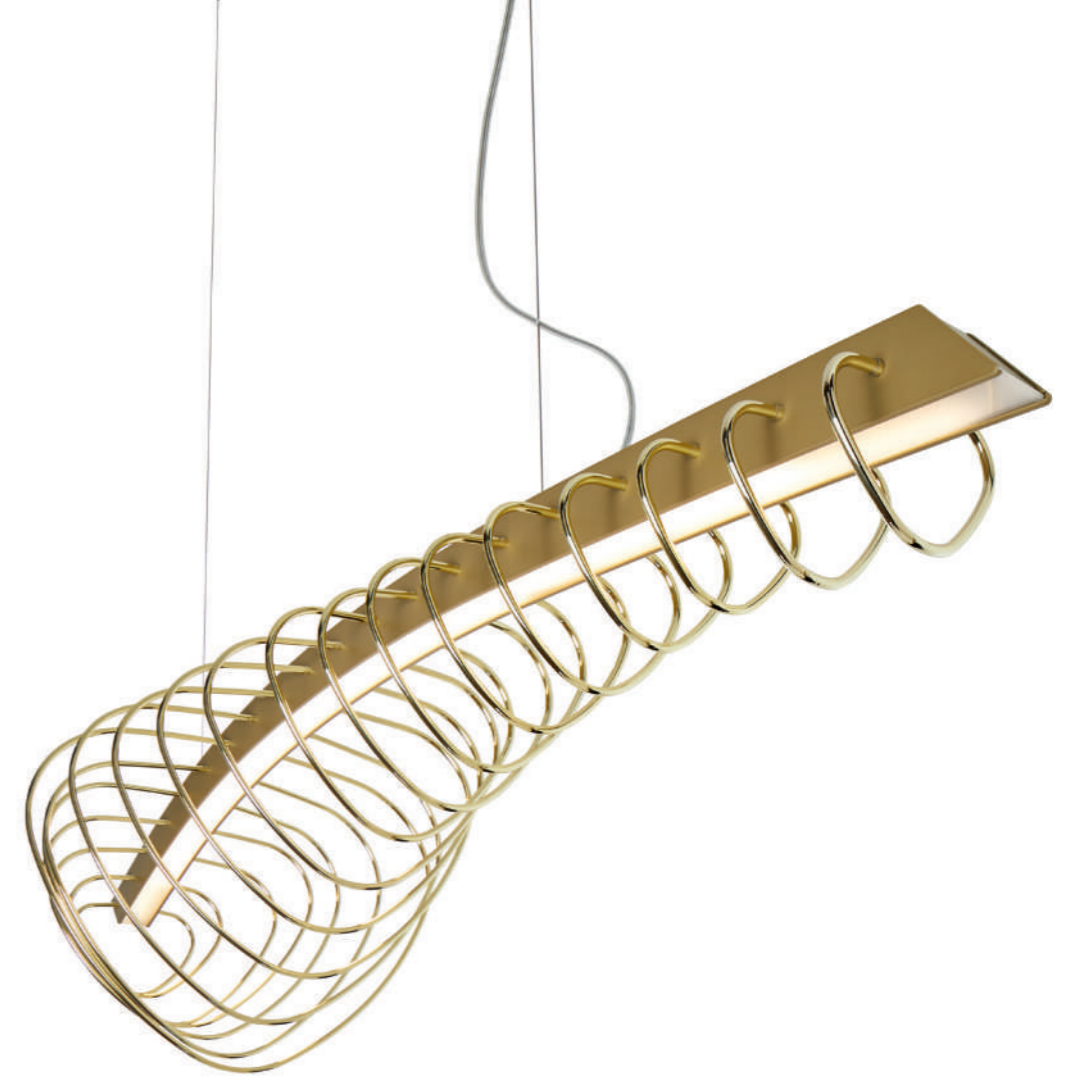

WHALE

Lampadina
Light bulb



Metallo
Metal

V2907
Bianco opaco
Matt white

V2910
Vernice oro opaco
Opaque gold color

Ottone lucido
Glossy brass

Diffusore
Diffuser

PMMA opale
Ice white

Art. 7378/1

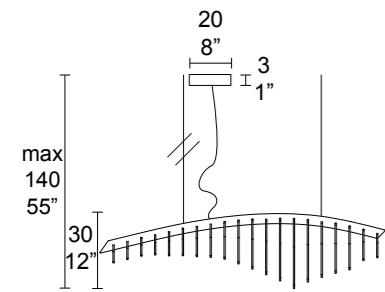
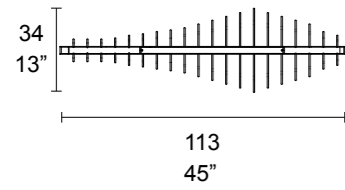



PETAL

STUDIO MAMMINI CANDIDO

Lampada da parete, dalla forma elegante e dalle linee pulite proposta in due misure. Arreda ogni superficie in cui viene installata con libertà e fantasia, come se fosse un vero e proprio giardino. La sua superficie materica la rende viva e vivace, alla stregua di un petalo di fiore mosso dal vento e conferisce dinamicità e raffinatezza ad ogni ambiente in cui si trova.

Wall lamp with an elegant shape and clean lines, available in two sizes. It decorates every surface where it is installed with freedom and imagination as if it were a real garden. It's material surface makes it alive and lively, like a flower petal moved by the wind and gives dynamism and refinement to every environment in which it is located.

7377/A1G

7377/A1P







PETAL

Lampadina
Light bulb

STRIP LED 15W
3000°K

LED STAR 1W
3000°K

Metallo
Metal

V2901
Ferro decapato
Pickled iron
(struttura esterna)

Acciaio anticato
Antiqued steel
(parte interna)

V2903
Ottone ossidato
Burnished brass
(struttura esterna)

Oro anticato
Antiqued gold
(parte interna)

Art. 7377/A1P

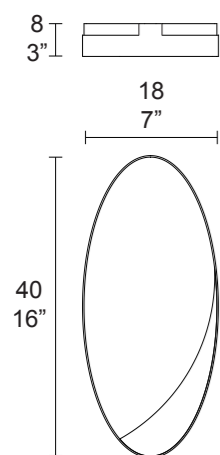

Art. 7377/A1G

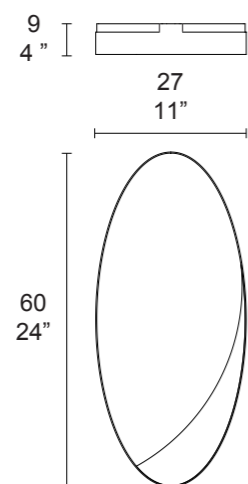



7375/P1



7375/P4

ARIA

ROBERTO FAVARETTO

Da sempre il confronto con il concetto di vuoto, ambiguo da rappresentare, è frutto di un continuo dibattito, proprio per il senso della sua esistenza e le leggi che lo governano.

Aria con le sue linee essenziali ne scolpisce le forme incorniciandolo e puntando ad esaltarlo. Ecco quindi che il metallo dai colori naturali ed un plafone luminoso materializzano l'assenza rendendola viva e teatrale nella composizione delle forme.

The confrontation with the concept of emptiness, which is ambiguous to represent, has always been the result of continuous debate, precisely because of the meaning of its existence and the laws that govern it.

Aria with its essential lines sculpts its shapes by framing it and aiming to enhance it. This is why the metal with its natural colors and a luminous ceiling materialize the absence, making it alive and theatrical in the composition of the forms.



7375/P2



7375/P3



COFFEE	2.5
ESPRESSO	2.5
MACCHIATO	3
CAPPUCCINO	3.5
LATTE	4
MOCHA	5
HAND POURED COFFEE	A.Q.
TEA	A.Q.
CHAI	4
COLD BREW BOTTLE	4





ARIA

Lampadina
Light bulb

LED
10/ 20/ 28 W
3000 K



Metallo
Metal

 V2907
Bianco Opaco
Matt white

 V0199
Nero opaco
Matt black

 V2902
Ottone ossidato
Burnished Brass

Diffusore
Diffuser

 PMMA opale
Ice white

Art. 7375/P1

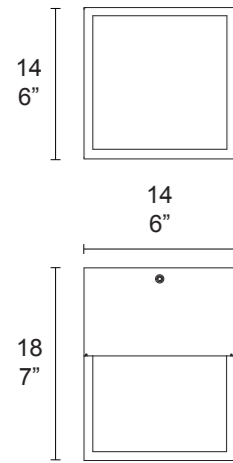

Art. 7375/P2

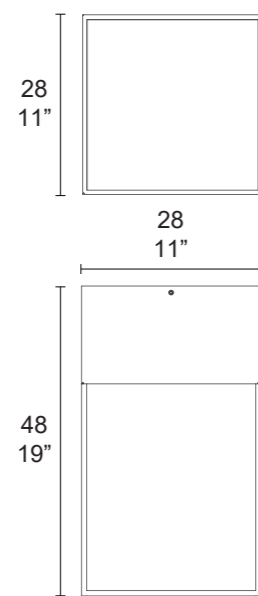

Art. 7375/P3

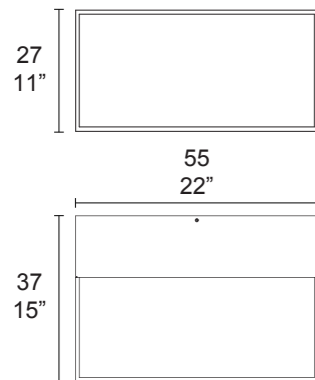

Art. 7375/P4

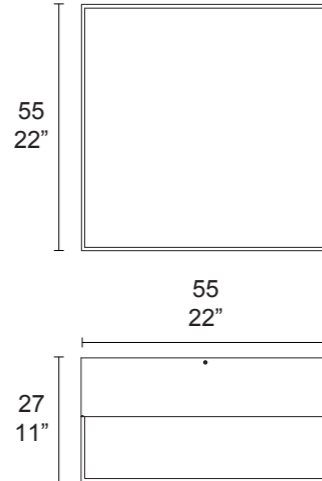



7382/

PARAMOUNT

ROBERTO FAVARETTO

Una linea unica e vigorosa controfirma le forme di Paramount, che allontana deliberatamente la ricerca della varietà decorativa dando varie possibilità teoriche di combinazioni allo stesso tempo. La scelta di utilizzare meno materiale possibile rispecchia, infatti, l'idea che ciò che immediatamente è comprensibile, è immediato e più ragionevole. Essenziale.

A unique and vigorous line countersigns the forms of Paramount that deliberately runs away the search of the decorative variety giving various theoretical possibilities of combinations at the same time. The choice to use less material possible it mirrors, in fact, the idea that what immediately is comprehensible, is immediate and more reasonable. Essential.

7382/L2



7382/



7382/



7382/



7382/

Nei chandelier Paramount ruota tutto attorno a tre elementi: small, medium, long. Possono essere utilizzati singolarmente oppure combinati con il rosone a due uscite per dare vita a Paramount double disponibile in versione S/ L1/ L2.

In Paramount chandeliers everything revolves around three elements: small, medium and long. They can be used individually or combined with the two-exit canopy to create Paramount double, available in the S/ L1/ L2 version.



7382/

Paramount può anche essere trasformato in sistema modulare di illuminazione a binario per interni.

Paramount can also be converted into an indoor modular track lighting system.

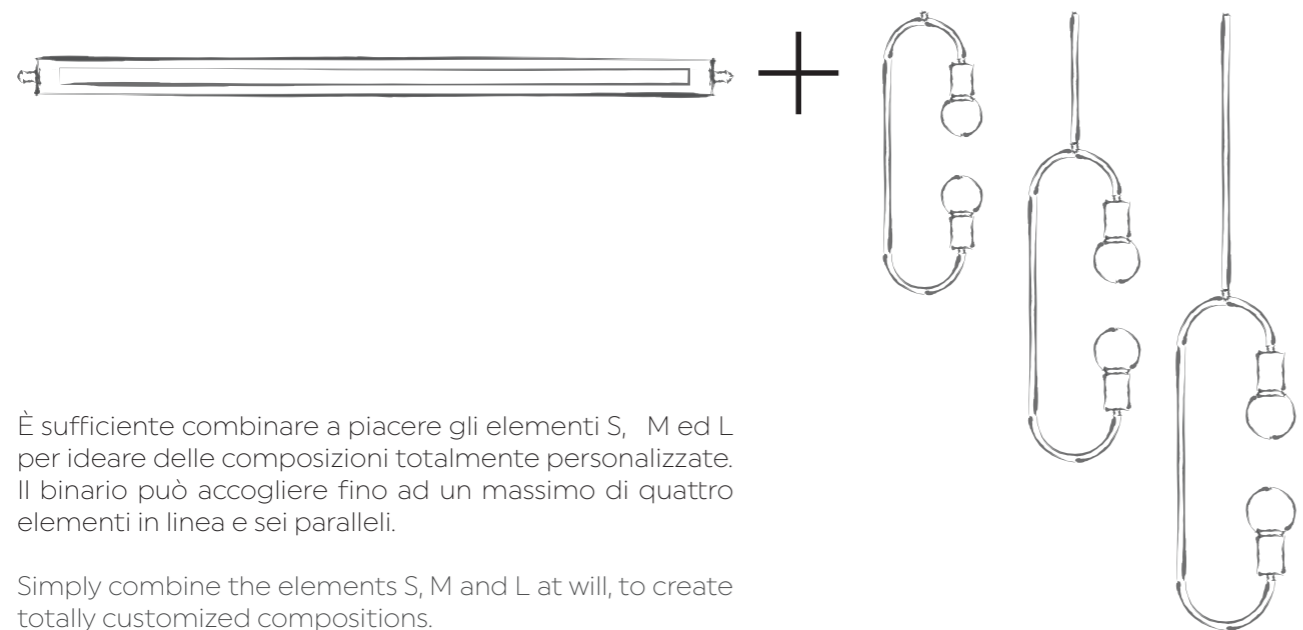

È sufficiente combinare a piacere gli elementi S, M ed L per ideare delle composizioni totalmente personalizzate. Il binario può accogliere fino ad un massimo di quattro elementi in linea e sei paralleli.

Simply combine the elements S, M and L at will, to create totally customized compositions. The track can accommodate up to four in-line and six parallel elements.

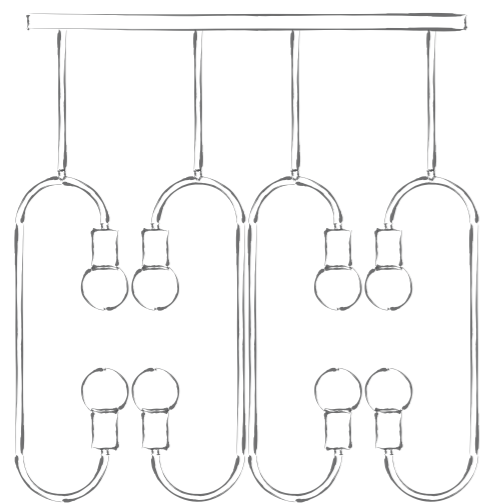

Max 4

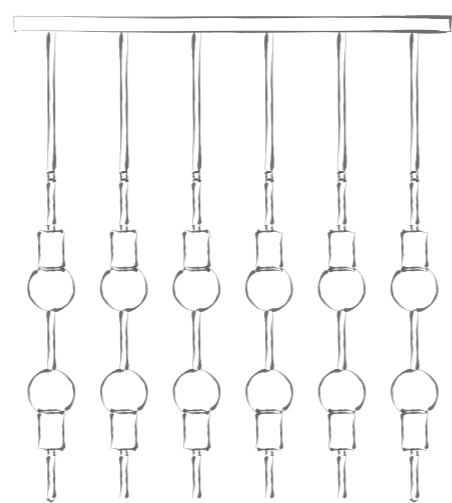

Max 6

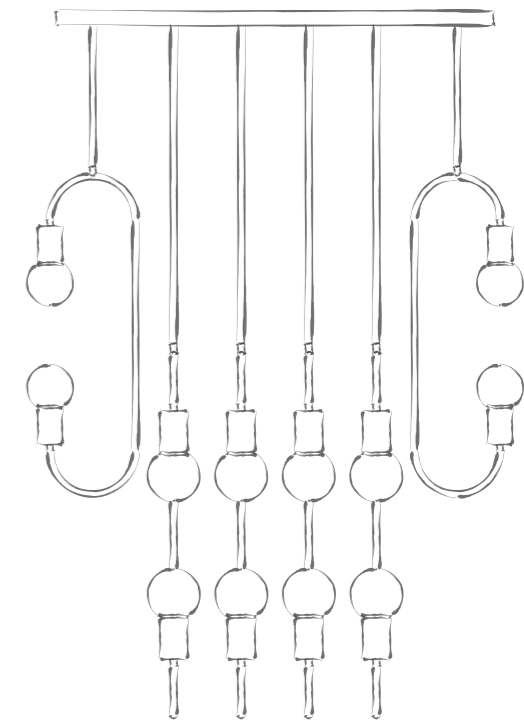
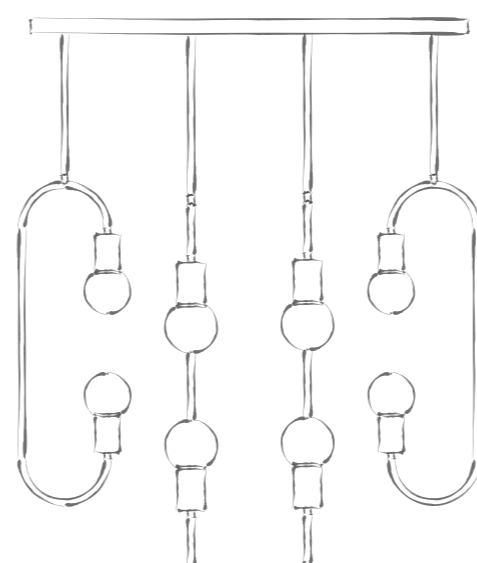
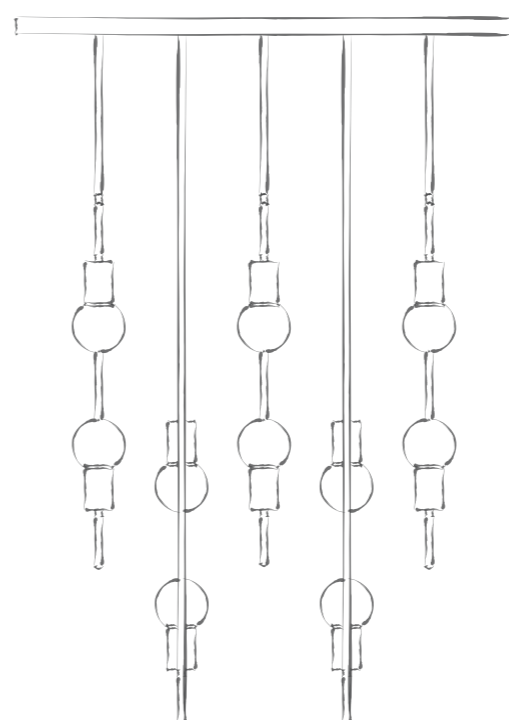

Esempi di composizioni

Examples of compositions





7382/LT2 G



7382/A2

PARAMOUNT

Lampadina
Light bulb

42W E27
Filament vintage
Ø125

Non compresa
nell'articolo, disponibile
su richiesta.

Not included. It is
available on request.

Metallo
Metal

V2905
Ottone ossidato
Burnished brass
(struttura esterna)

Nero opaco
Matt black
(dettagli)

V2906
Nero opaco
Matt black
(struttura esterna)

Ottone ossidato
Burnished brass
(dettagli)

Art. 7382/LT2 G

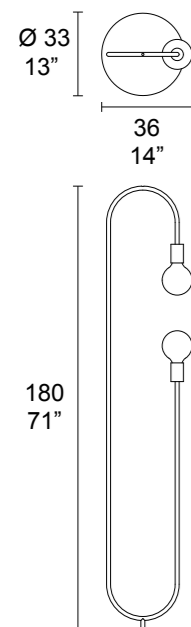

Art. 7382/A2

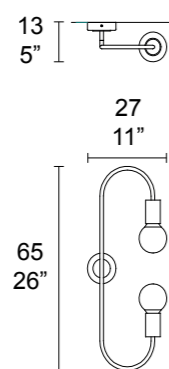

Art. 7382/L2

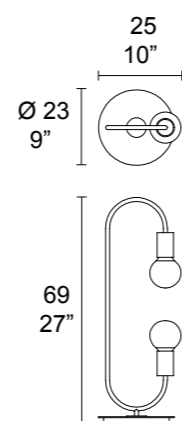

Art. 7382/1 - 00

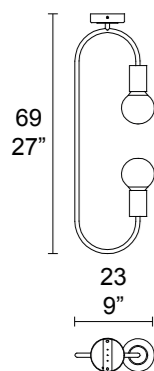

Art. 7382/1 - 01

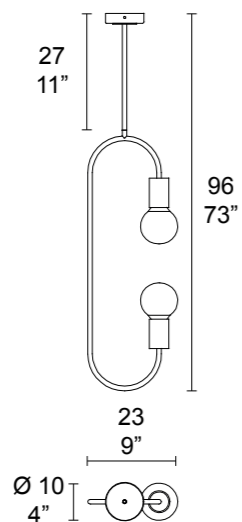

Art. 7382/1 - 02

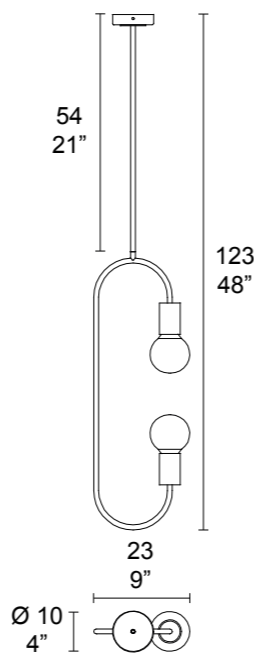

COMPOSIZIONI

Paramount double L2

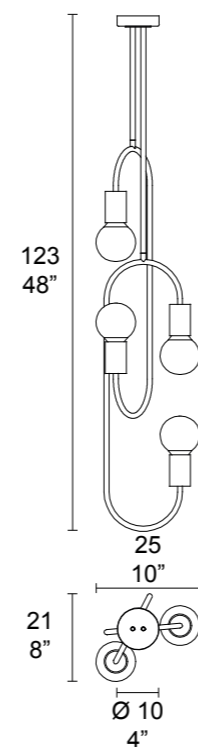

Paramount double L1

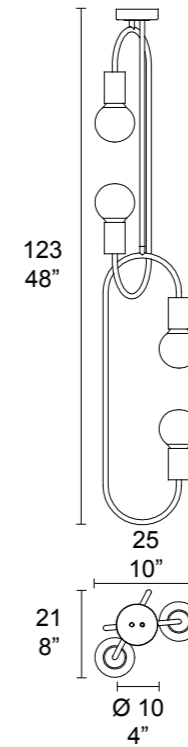

Paramount double S

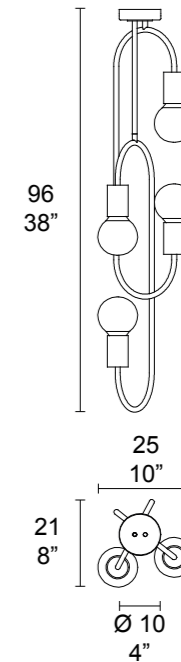

Paramount triple

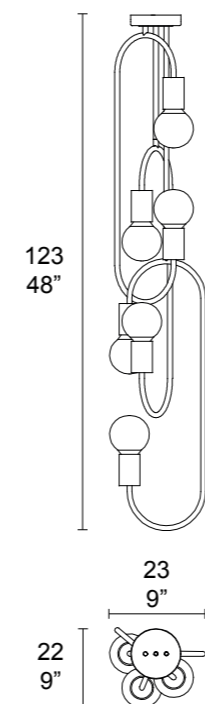

Paramount multiple

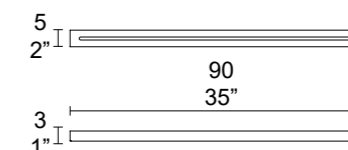

+

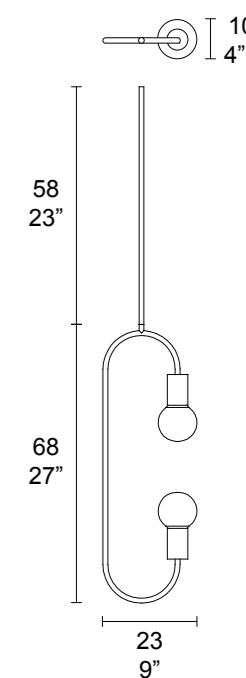
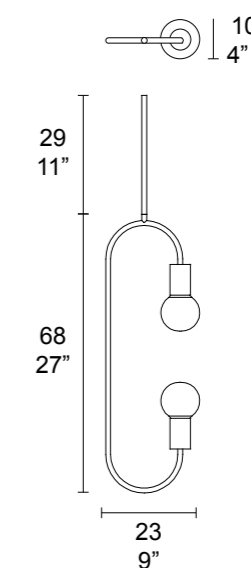
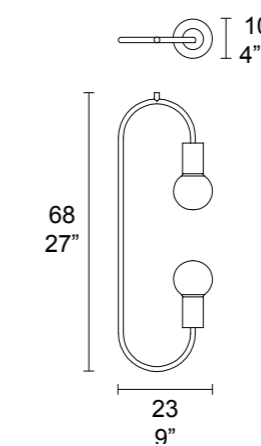

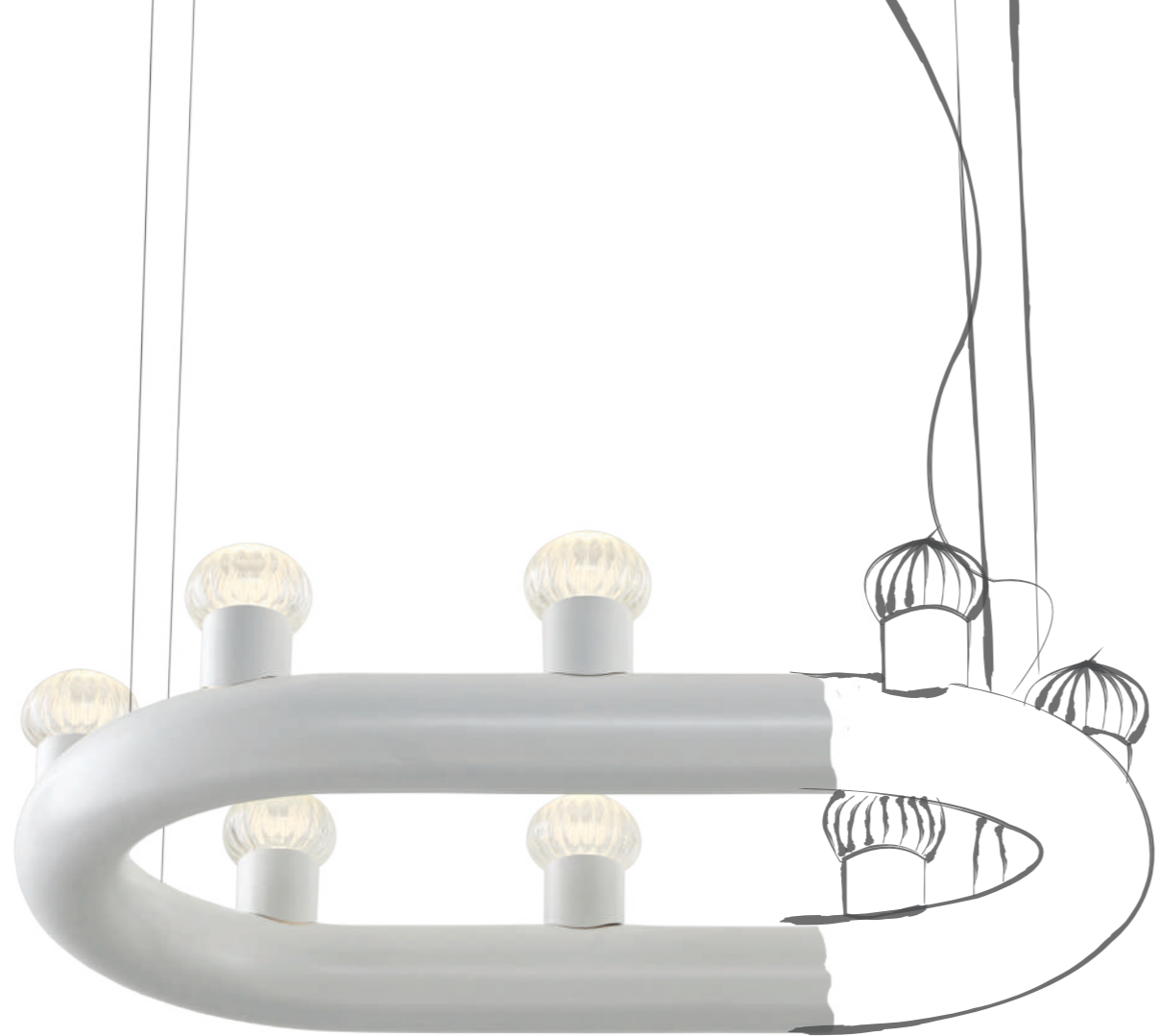

7376/8

KINGDOM

LEO DE CARLO

MIST

Nel medioevo e nel rinascimento, l'illuminazione delle abitazioni era ottenuta mediante candelabri e lampade ad olio organizzate in maniera cadenzata su anelli in ferro o legno. Kingdom è la reinterpretazione di questo archetipo di lampada, adattato al gusto contemporaneo: un semplice anello tubolare da cui spuntano, in maniera ripetuta e ordinata, delle "candele tecnologiche" arricchite da un elemento decorativo in vetro lavorato.

In the Middle Ages and the Renaissance, the lighting of dwellings was obtained using candelabra and oil lamps arranged in a cadence on iron or wood rings. Kingdom is the reinterpretation of this lamp archetype, adapted to the contemporary taste: a simple tubular ring from which emerge, in a repeated and orderly manner, of "technological candles" enriched by a decorative element in worked glass.

7376/6





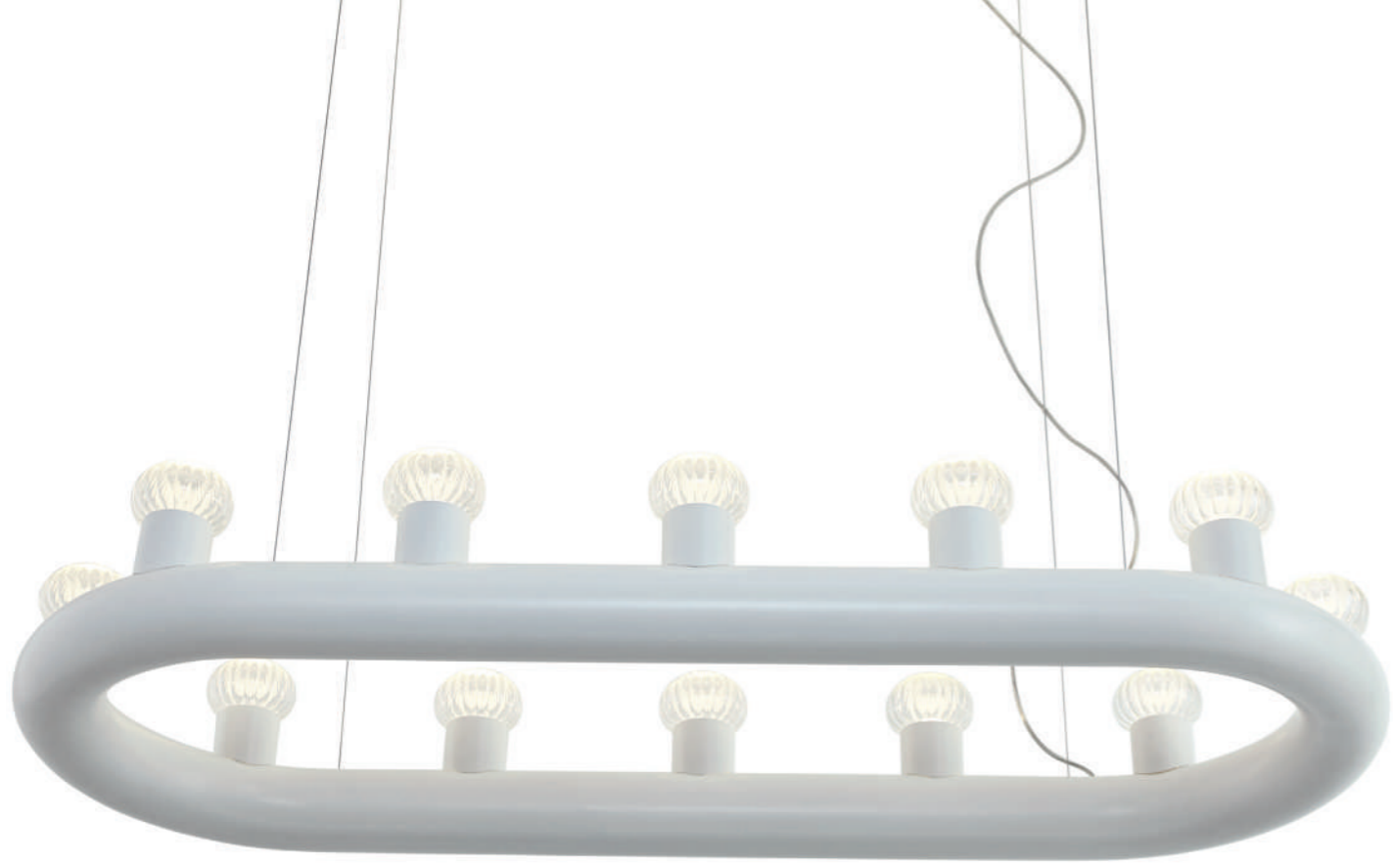

7376/12



7376/A2





KINGDOM

Lampadina
Light bulb

28W E14 C35



Metallo
Metal

V2907
Bianco Opaco RAL
Matt White RAL

V0266
Brunito galvanico
Galvanic burnished

Vetro
Glass

Rigato
Trasparente
Transparent

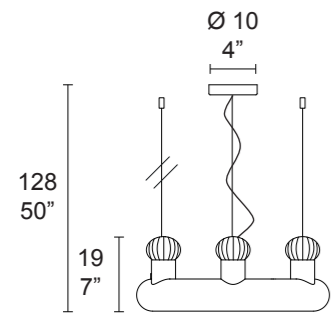
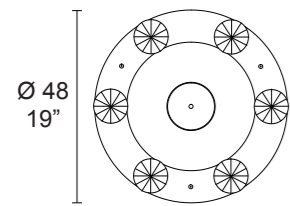

Art. 7376/6

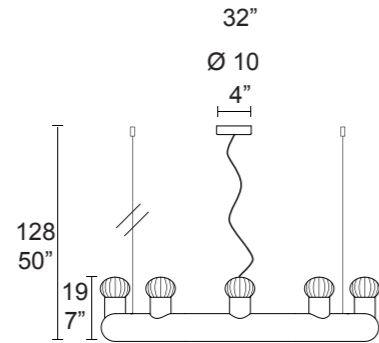
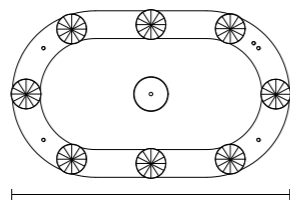

Art. 7376/8

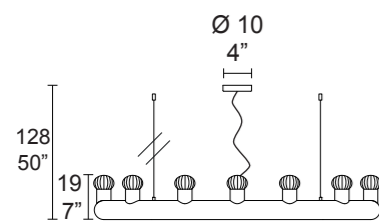
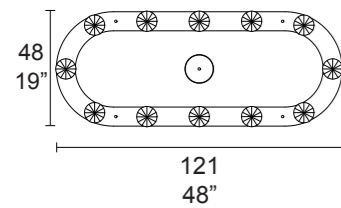

Art. 7376/12



Art. 7376/A2

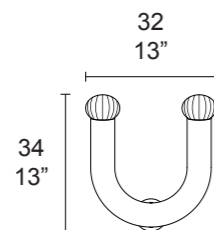
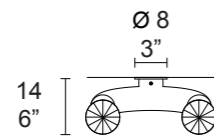



RAIN

MM LAMPADARI

Le suggestioni che la pioggia suscita cambia anche la visione del mondo che ci circonda cadendo dal cielo e rendendo suggestivo ogni luogo.

E proprio come la pioggia che scende leggera e diligente anche gli elementi di queste lampade ridisegnano l'ambiente con costanti intrecci di fili obliqui a formare una trama di bulbi in vetro specchiato lucenti.

The suggestions that the rain provokes also change the vision of the world that surrounds us, falling from the sky and making every place evocative.

Just like the rain that falls lightly and diligently, the elements of these lamps redesign the environment with constant interlacing of oblique threads to form a weave of shiny mirrored glass bulbs.

7379/1





7379/3

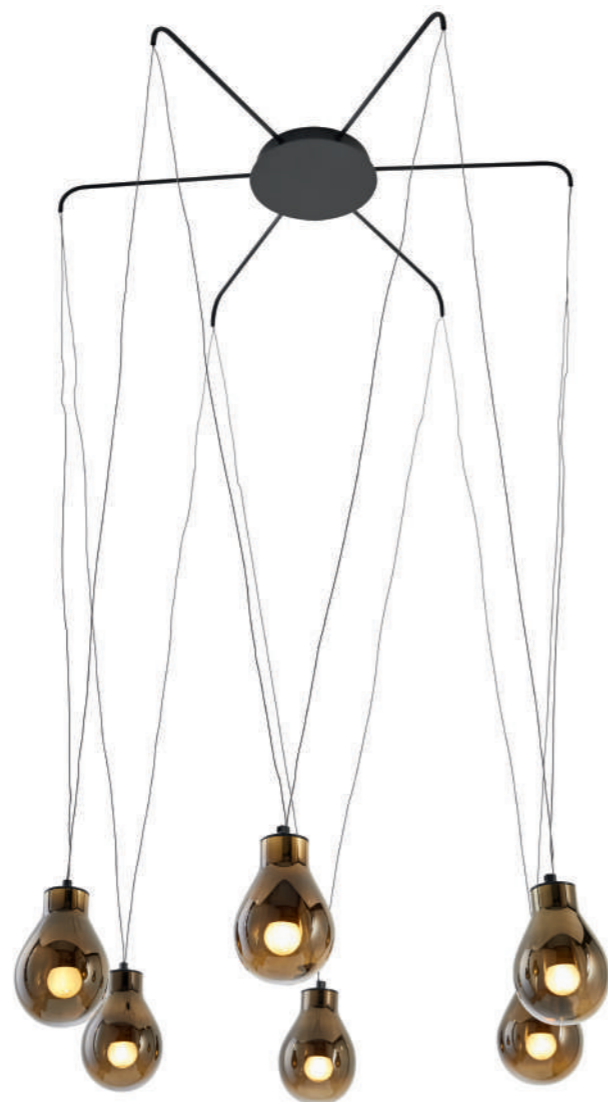

7379/6

La famiglia Rain è pensata per poter unire i plafoni a Matrioska, ed accorciare i cavi a piacere, in modo da realizzare un chandelier ogni volta Bespoke.

The Rain range is designed for bringing together the plates as a Matrioska, and shorten cables as wished, in order to create a customized chandelier.

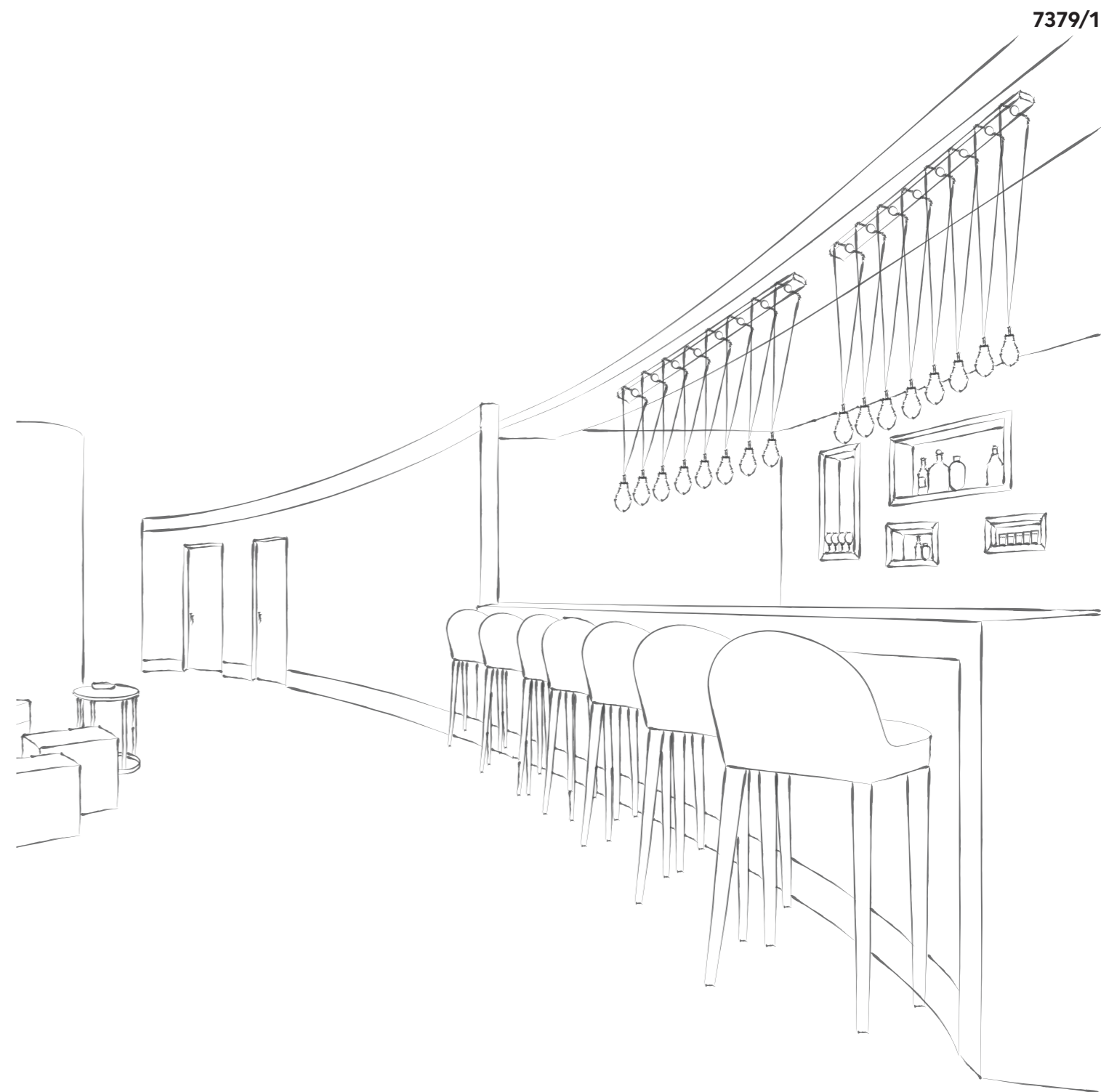

7379/1

7379/24





7379/45



RAIN

Lampadina
Light bulb

28W eco E14
Classic P45



Metallo
Metal

V0199
Nero opaco
Matt black

Vetro
Glass

Vetro trasparente
Transparent glass

Fumé metallic
Metallic fumé

Art. 7379/1

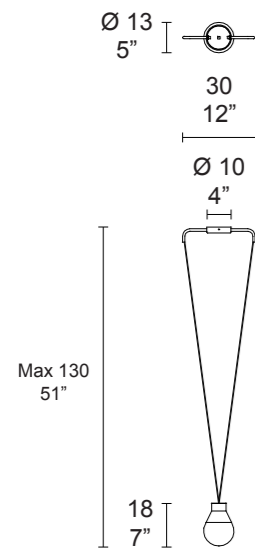

Art. 7379/3

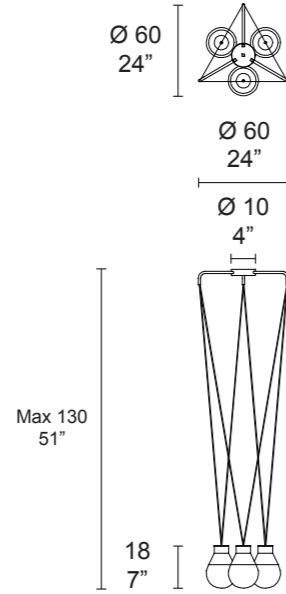

Art. 7379/6

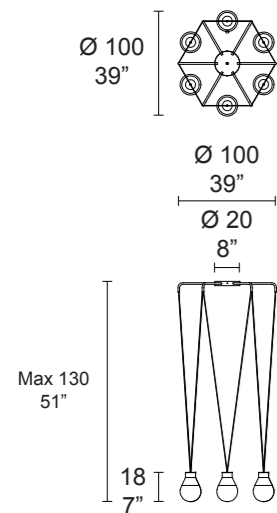

Art. 7379/9

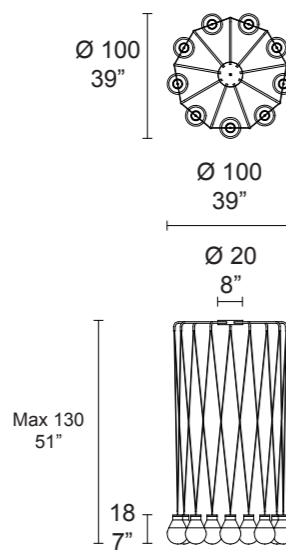

RAIN

Art. 7379/12

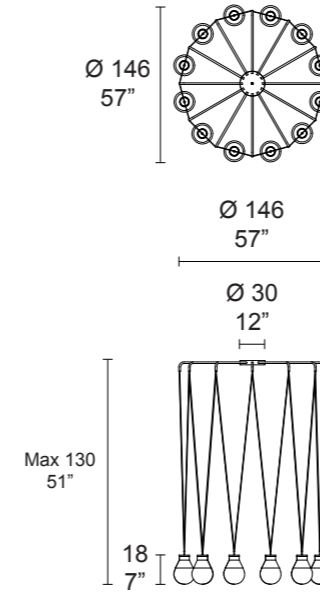

Art. 7379/24

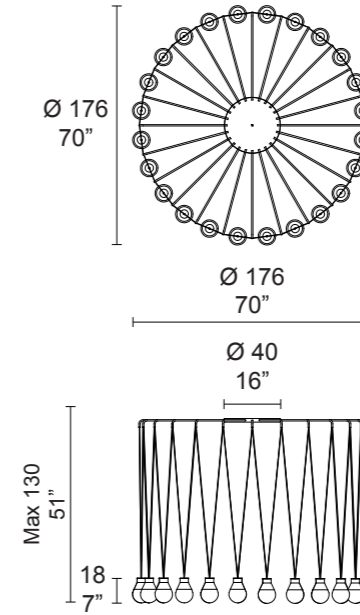

Art. 7379/45

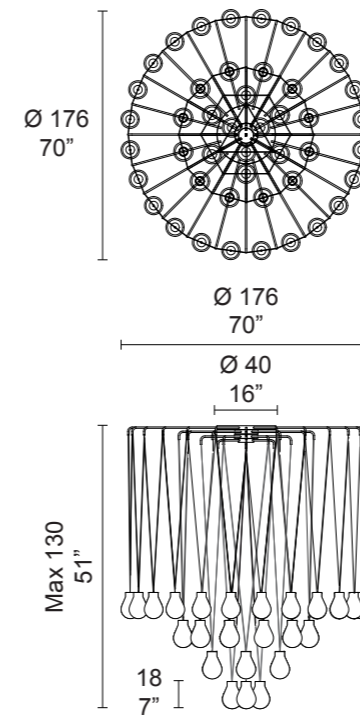



JACK

OLGA ENGEL

Lo stile neoclassico ed impero ispirano questa lampada che trasforma gli elementi decorativi in cristallo di forma geometrica ed allungata in un motivo ripetuto e circolare installato però in orizzontale ed in metallo arricchendo Jack di nuovi giochi di luce. La sua struttura cinetica permette di spostare alcune delle sue parti, cambiandone così il suo diametro e conferendole un design in continua evoluzione.

The neoclassical and empire style inspires this lamp that transforms the decorative crystal elements of geometric and elongated shape into a repeated and circular motif installed horizontally and in metal, enriching Jack with new plays of light. Its kinetic structure allows moving some of its parts, thus changing its diameter and giving it a continuously evolving design.



7380/1



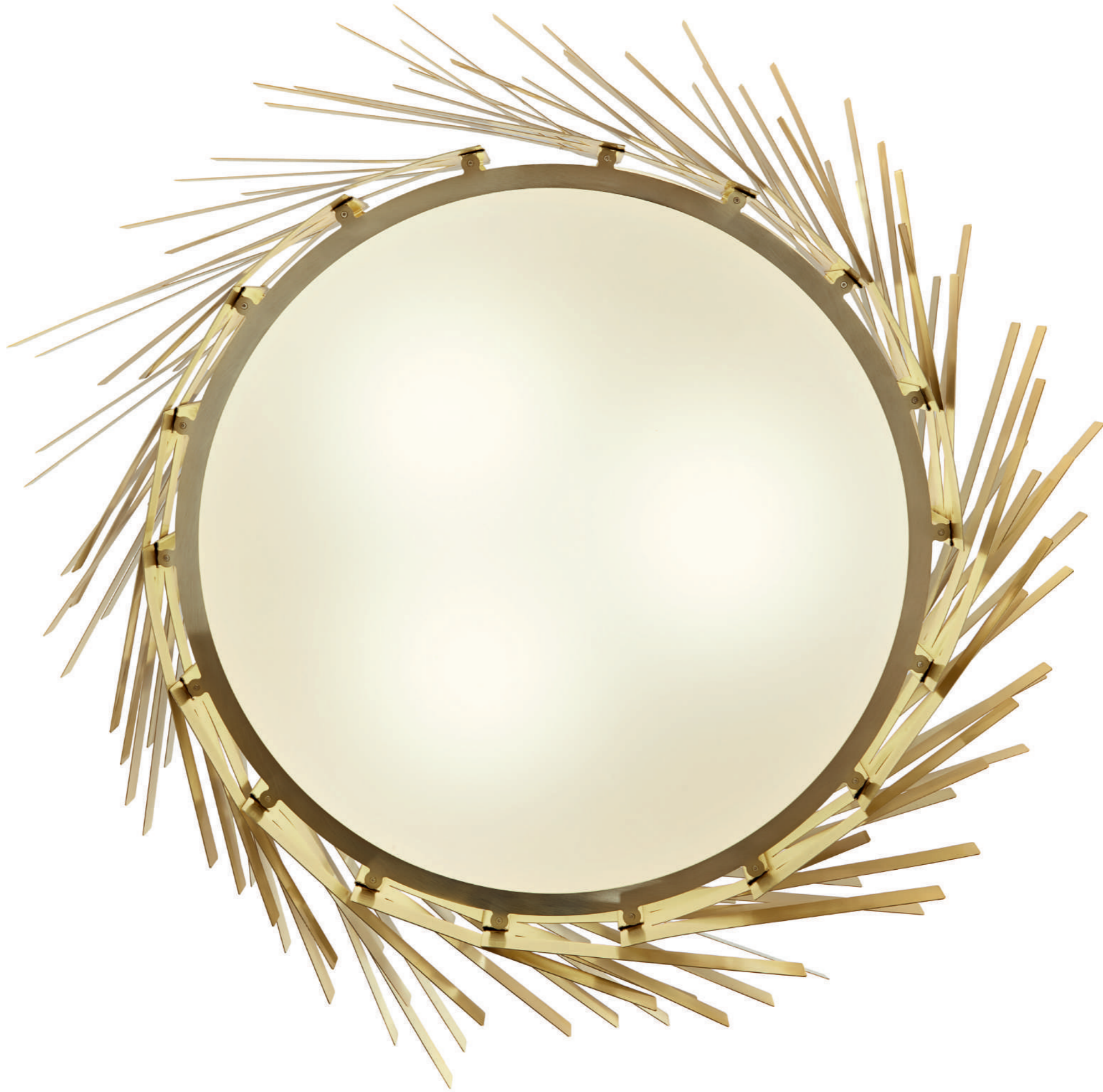

JACK

Lampadina
Light bulb

LED
20 W 8600lm
3000°K
A++-E

Metallo
Metal

V2907
Bianco opaco
Matt White

V0216
Ottone lucido
Glossy brass

V2805
Ottone satinato
Satin brass

Diffusore
Diffuser

PMMA opale
Ice white

Art. 7380/1

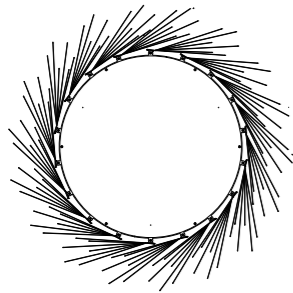

Ø 110
43"

Ø10
4"

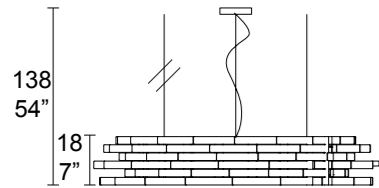



CODE

UFFICIO TECNICO MM LAMPADARI

Un assieme di semplici elementi dà vita a questa lampada. Due linee luminose per illuminare l'ambiente in maniera bidirezionale e che possono essere accese in maniera indipendente. Cover facili da montare e colori di impatto che lasciano il segno. Viene proposta nelle finiture grezze dell'ottone acidato e ferro decapato oppure con il rivestimento in pelle nera per un effetto più elegante.

A combination of simple elements gives life to this lamp. Two light lines to illuminate the room bidirectionally and which can be switched on independently. Easy-to-fit covers and striking colours that leave their mark. It is available in the raw finishes of acid-etched brass and pickled iron or with black leather upholstery for a more elegant effect.

7381/1 02





La famiglia è disponibile in tre misure differenti e grazie alle cover easy on è possibile scegliere la finitura che più si addice all'ambiente, ed in caso di installazione in altro luogo di sostituirla autonomamente ordinandone un colore diverso fra quelli disponibili.

The family is available in three different sizes and thanks to the easy on covers it is possible to choose the finish that best suits the environment, and in case of installation in another place to replace it independently ordering a different color among those available.



CODE

Lampadina
Light bulb

STRIP LED
25/ 35/ 45 W
3000K



Metallo
Metal

V2905
Ottone ossidato
Burnished brass
(struttura esterna)

Nero opaco
Matt black
(struttura interna)

V2916
Ferro Decapato
Pickled iron
(struttura esterna)

Nero opaco
Matt black
(struttura interna)

V0199
Rivestimento in pelle
Leather
(struttura esterna)

Nero opaco
Matt black
(struttura interna)

Diffusore
Diffuser

PMMA opale
Ice white

CODE

Art. 7381/A1-02 L

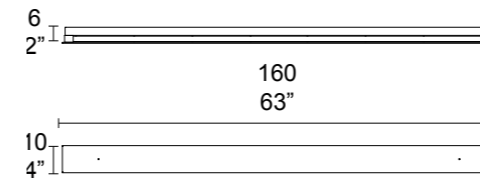

Art. 7381/A1-01 M

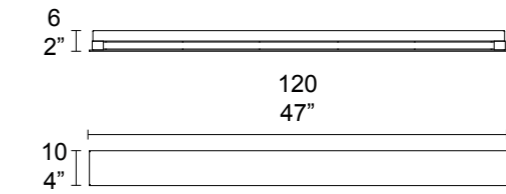

Art. 7381/A1-00 P

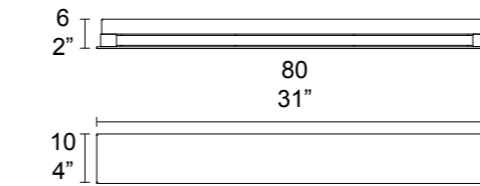

Art. 7381/02 L

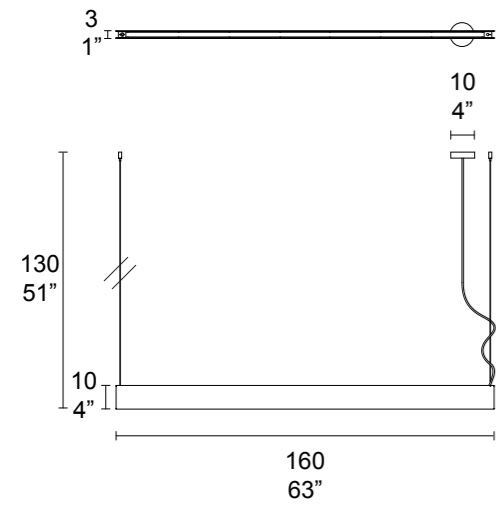

Art. 7381/01 M

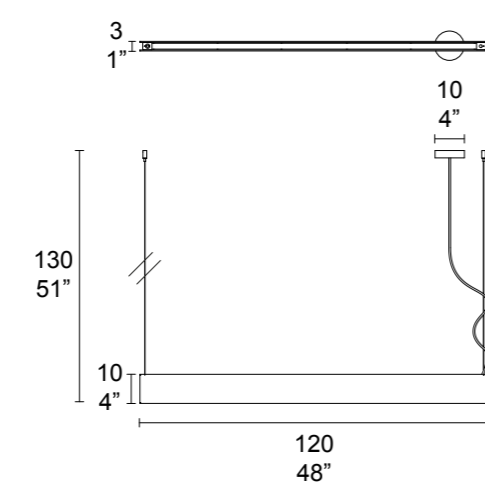

Art. 7381/00 P

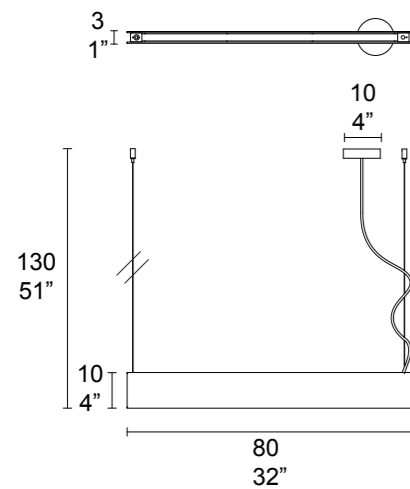



CLESSIDRA

MATTEO ZORZENONI

Clessidra è un progetto di lampade modulari caratterizzate da forme pure e eleganti: una ciotola rivolta verso l'alto e una verso il basso connesse da un semplice tubo, entrambi illuminanti, permettono una perfetta illuminazione. Possono essere utilizzate singolarmente oppure con struttura a ragno che permette di creare un'infinita varietà di composizioni. Struttura in metallo, illuminazione led.

Clessidra is a project of modular lamps characterised by pure and elegant shapes: a bowl facing upwards and one downwards connected by a simple tube, both illuminating, allow perfect lighting. They can be used individually or with a spider structure that allows you to create an infinite variety of compositions. Metal structure, led lighting.

7331/8



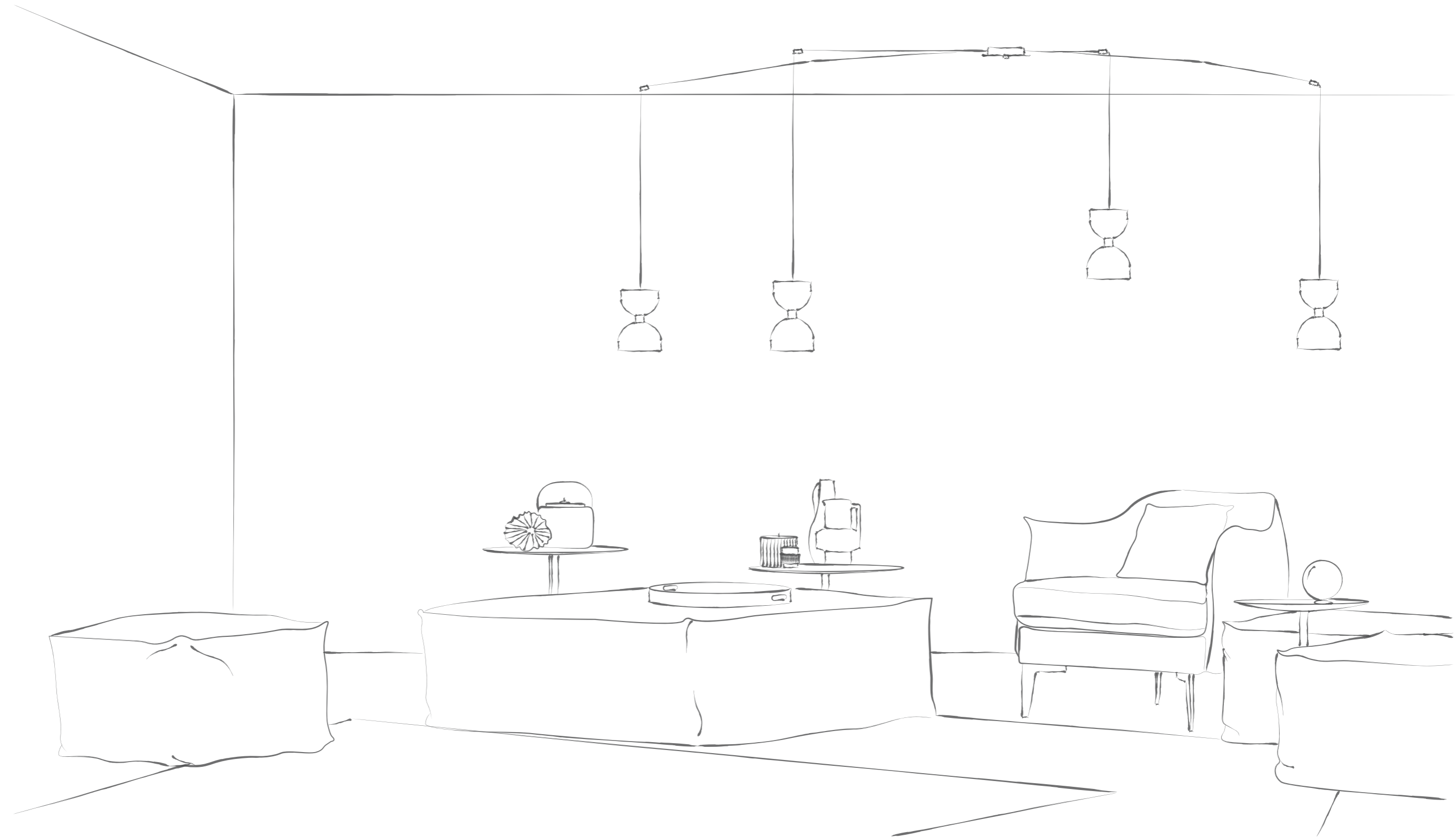



7331/2



7331/A2



7331/48



7331/16

7331/8

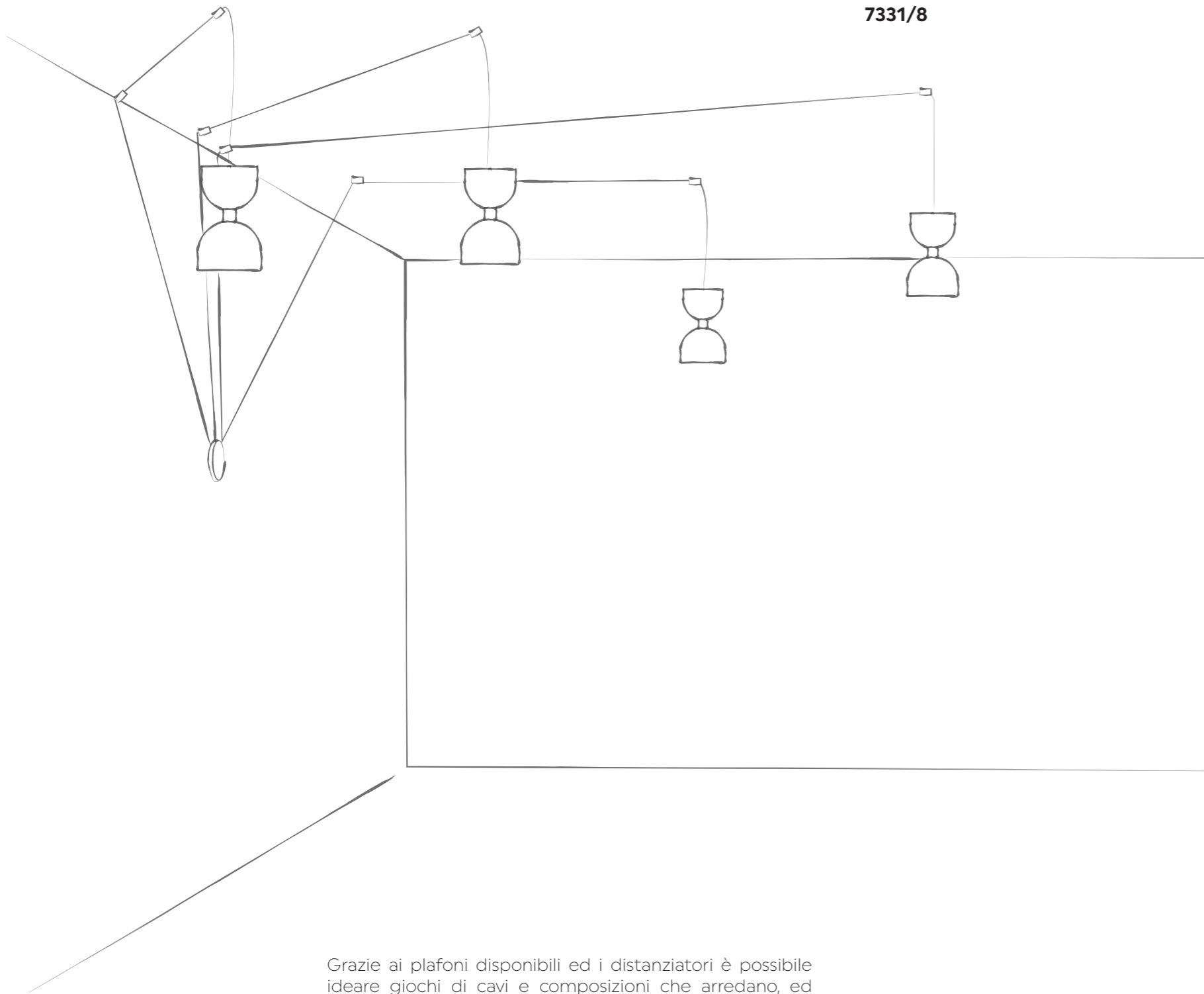

Grazie ai plafoni disponibili ed i distanziatori è possibile ideare giochi di cavi e composizioni che arredano, ed illuminano la stanza in più punti.

Thanks to the available ceiling lamps and spacers, it is possible to create plays of cables and compositions that furnish and illuminate the room in several places.



CLESSIDRA

Lampadina
Light bulb

LED
LED BOARD 4,5W
3000°K



LED
LED BOARD 8W
3000°K



Metallo
Metal

○ V2852
Bianco opaco con
particolari in
ottone lucido
● Matt white with
glossy brass details

● V2853
Nero opaco con
particolari in
ottone lucido
● Matt black with
glossy brass details

Diffusore
Diffuser

○ PMMA opale
Ice white

Art. 7331/48 (24 pendenti/pendants)

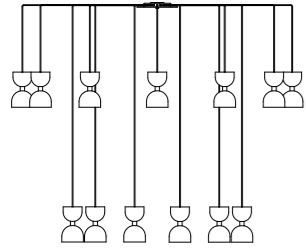
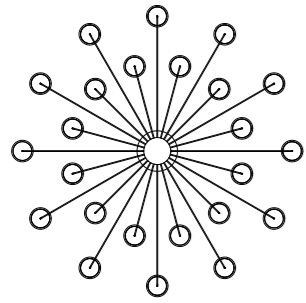

Art. 7331/16 (8 pendenti/pendants)

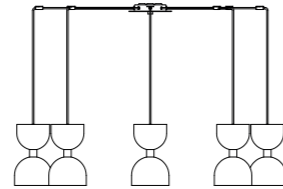
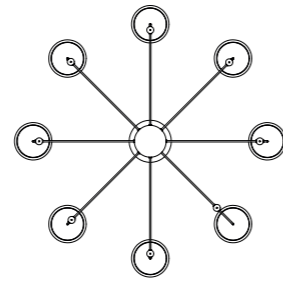

Art. 7331/8 (4 pendenti/pendants)

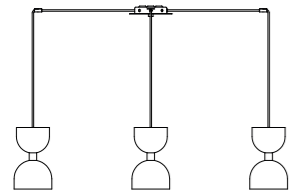
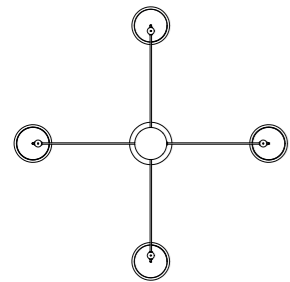

Art. 7331/2 (1 pendente/pendant)

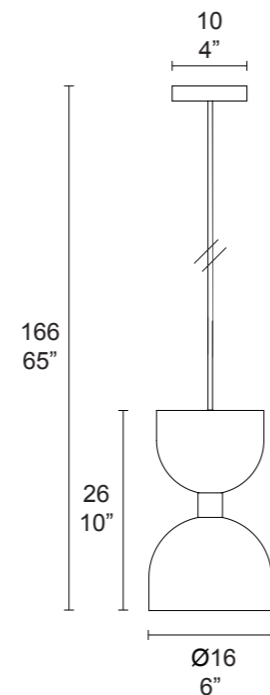

CLESSIDRA

Art. 7331/A2

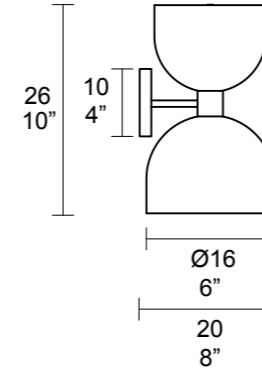

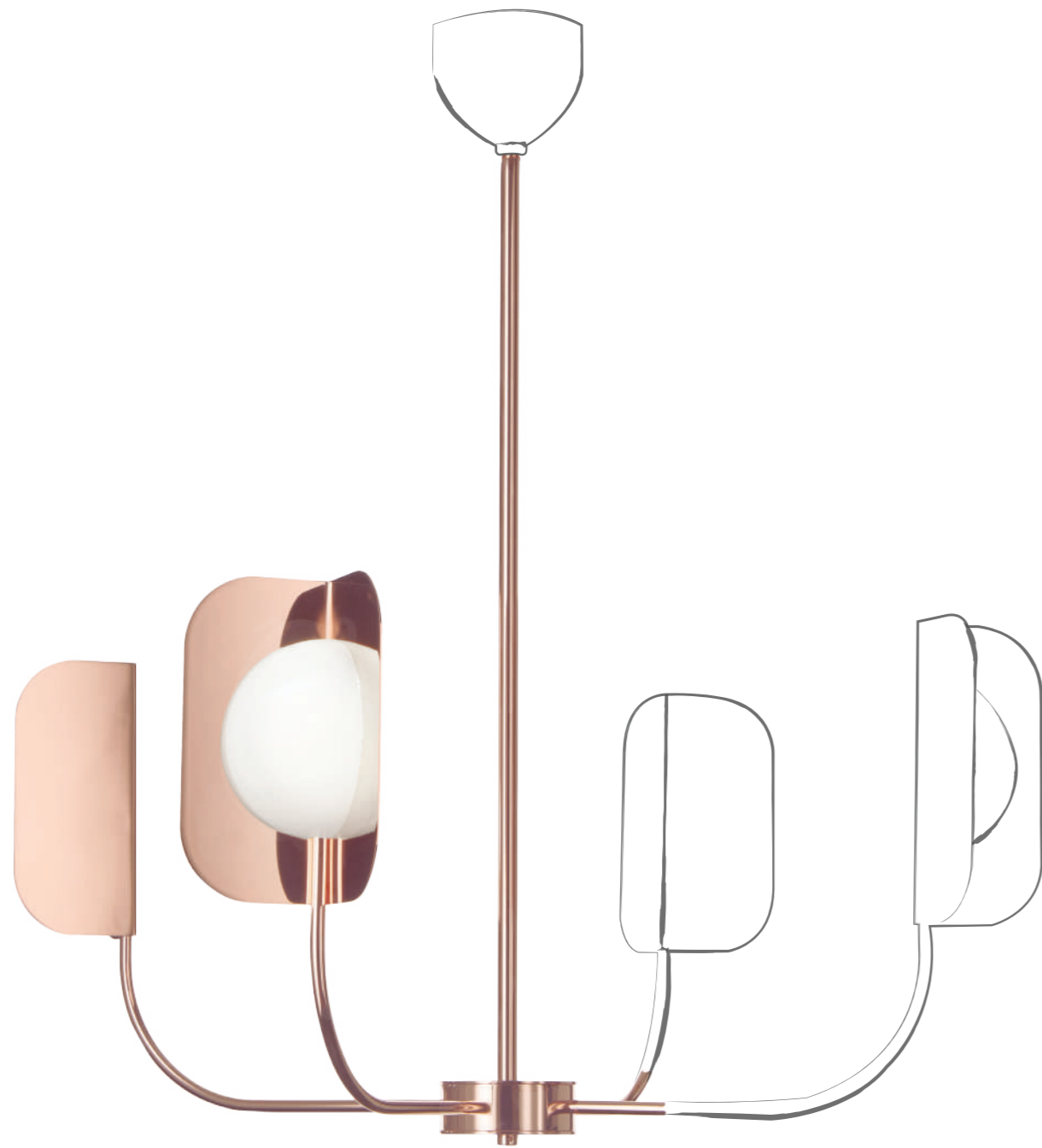

LEAF

MATTEO ZORZENONI

Ispirata alla natura e all'armonia degli spazi, Leaf propone una struttura metallica leggera ed eclettica in metallo, con diffusore in vetro frutto di un'accurata ricerca progettuale. Avulsa da qualsiasi stile, le sue forme pulite che ne esaltano la silhouette nello spirito del minimalismo, si integra perfettamente in qualsiasi ambiente evidenziandone il carattere.

Inspired by nature and the harmony of space, Leaf proposes a light and eclectic metal structure, with glass diffuser, the result of careful design research. It is free from any style, its clean shapes that enhance the silhouette in the spirit of minimalism, it integrates perfectly into any environment highlighting its character.

7208/24





7208/4

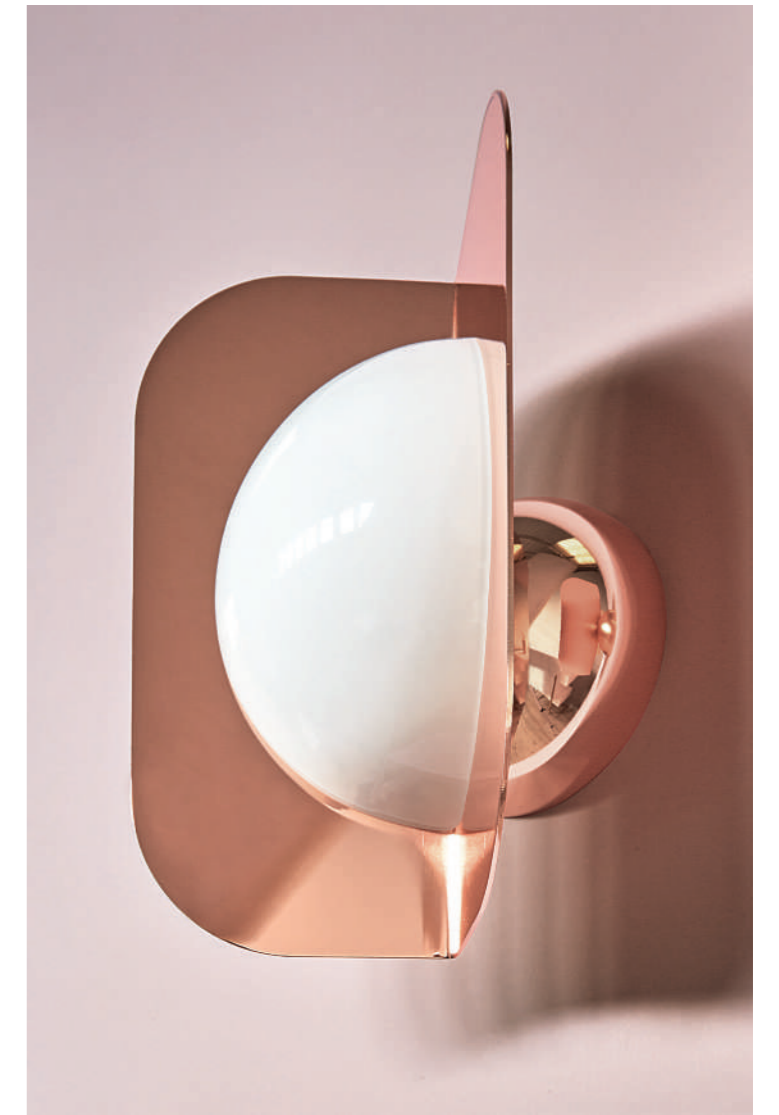

7208/A1



7208/LT3



7208/2



7208/12



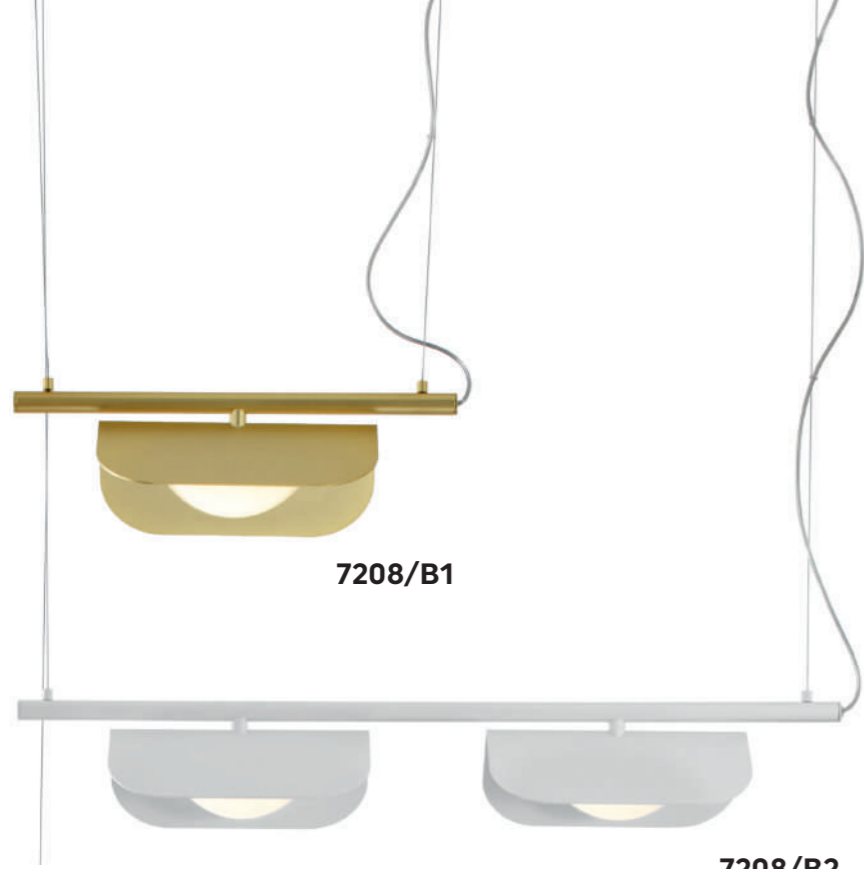

7208/B2

7208/B4



LEAF

Lampadina
Light bulb

5W G9
non include
not included

LED
LED BOARD 4,5W
220-240V
3000°K
include
included

DIM

Metallo
Metal

- V0199
Nero opaco
Matt black
- V2806
Rame lucido
Glossy copper
- V0216
Ottone lucido
Glossy brass
- V2807
Rame satinato
Satin copper
- V2805
Ottone satinato
Satin brass
- V0266
Brunito galvanico
Burnished

Vetro
Glass

- Vetro bianco
White glass

Art. 7208/2

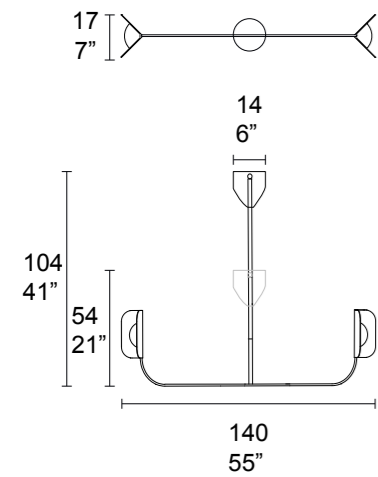

Art. 7208/4

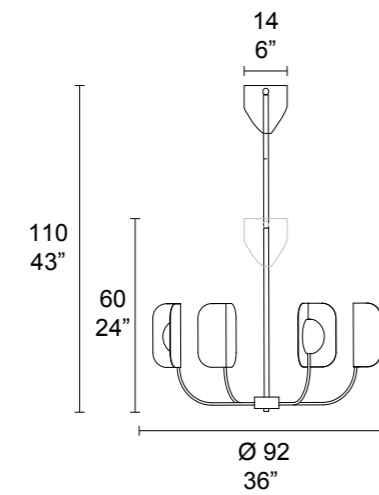

Art. 7208/8

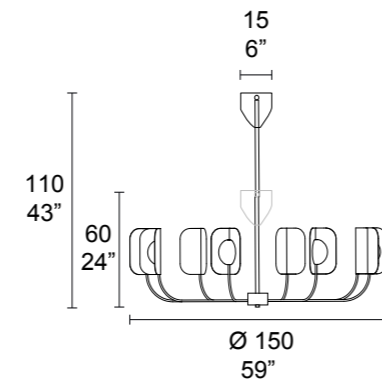

Art. 7208/12

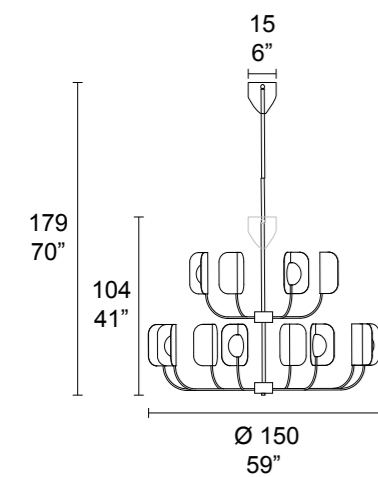

Art. 7208/24

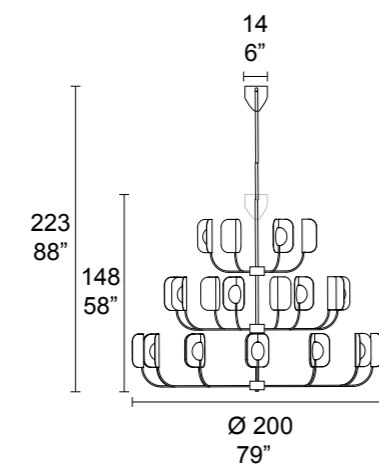

Art. 7208/A1

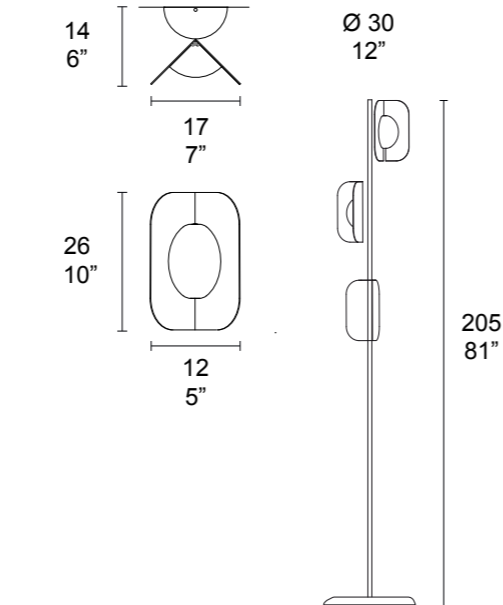

Art. 7208/LT3

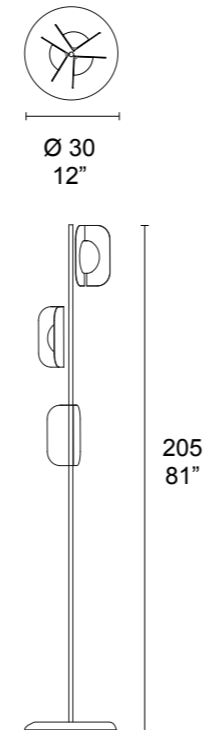

LEAF

Lampadina
Light bulb

LED
1 x LED BOARD
4,5W 220-240V
3000°K
include
included

DIM

Metallo
Metal

- V0199
Nero opaco
Matt black
- V2900
Ferro decapato
Pickled iron
- V0216
Ottone lucido
Glossy brass
- V2807
Rame satinato
Satin copper
- V2805
Ottone satinato
Satin brass
- V2806
Rame lucido
Glossy copper
- V2824
Ottone opaco
Matt brass
- V0266
Brunito galvanico
Burnished

Vetro
Glass

- Vetro bianco
White glass

NEW
Art. 7208/B4

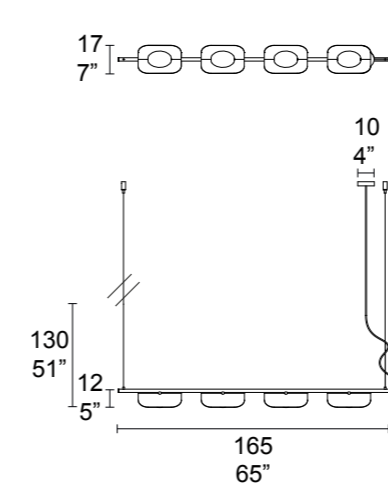

NEW
Art. 7208/B2

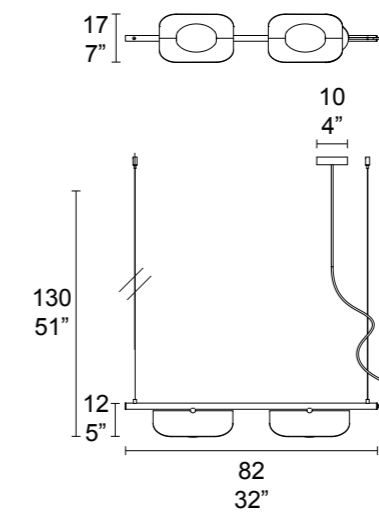

NEW
Art. 7208/B1

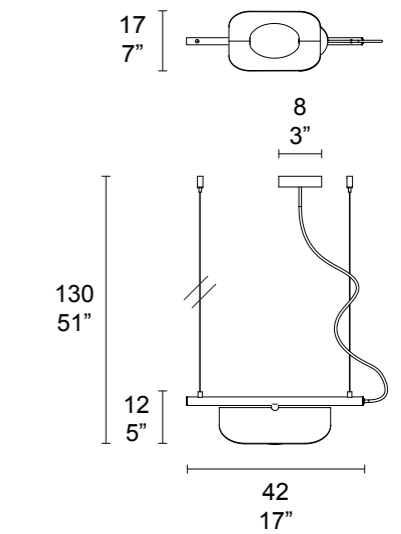

ARABESQUE

UFFICIO TECNICO MM LAMPADARI



6986/1



6983/1



6996/1



6985/1



6984/1

La raffinatezza e sofisticatezza del vetro soffiato di Murano si sposano con gli ornamenti che trasmettono serenità e bellezza. È così che la serie di lampade Arabesque omaggia un'arte antica del bello declinandola in tutte le sue forme e dove protagonisti diventano i dettagli ed i riflessi che la luce trasmette.

The refinement and sophistication of Murano blown glass are combined with the ornaments that convey serenity and beauty. This is how the Arabesque series of lamps pays homage to an ancient art of beauty, declined in all its forms and where the protagonists become the details and reflections that light transmits.



6985/L1



6996/L1



6997/L1



6987/4





ARABESQUE

Lampadina
Light bulb



Metallo
Metal

-  V1607
Chromo lucido
Glossy chrome
-  V2553
Bianco lucido
Glossy White

Vetro
Glass

-  Bianco lucido
Glossy white

Art. 6983/1

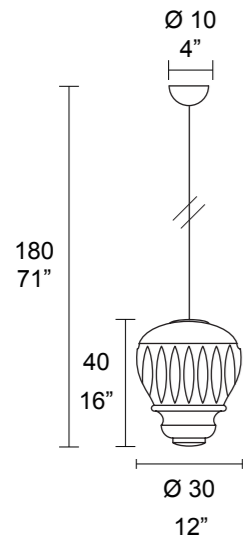

Art. 6984/1

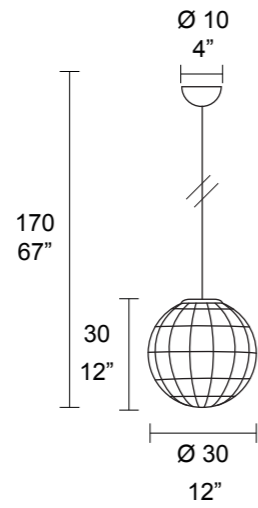

Art. 6985/1

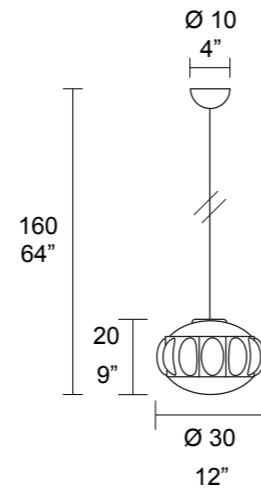



ARABESQUE

Lampadina
Light bulb



Metallo
Metal

-  V1607
Chromo lucido
Glossy chrome
-  V2553
Bianco lucido
Glossy White

Vetro
Glass

-  Bianco lucido
Glossy white

Art. 6985/L1

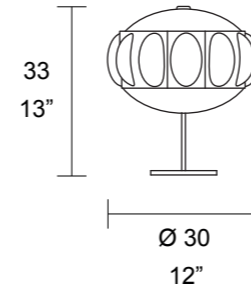

Art. 6997/L1

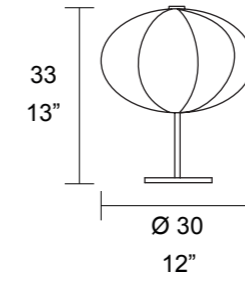

Art. 6996/L1

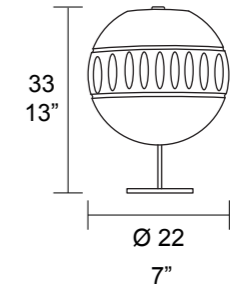

Art. 6986/1

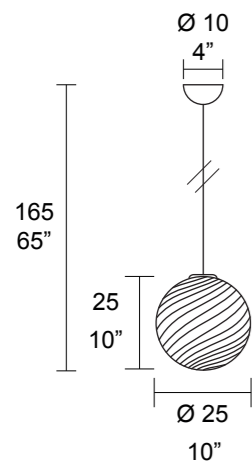

Art. 6996/1

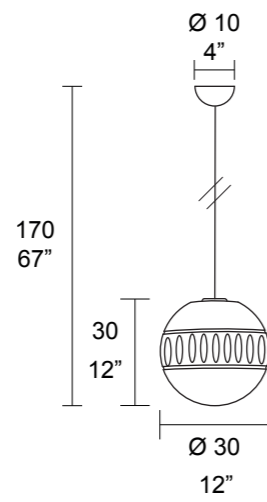

Art. 6987/4

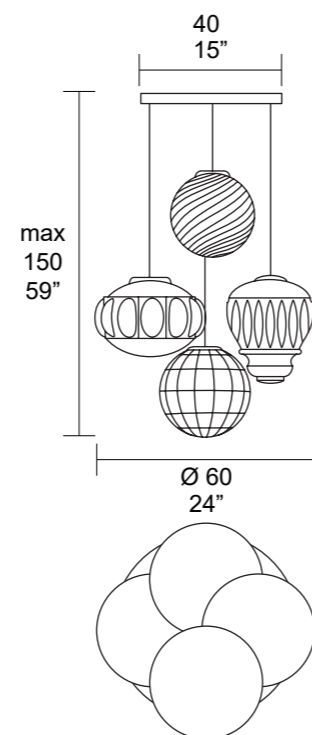

MOONLIGHT

MATTEO ZORZENONI



Moonlight è una collezione di lampade dalla forte connotazione grafica.

Scegliendo fra tre disegni diversi di lamiere metalliche sagomate ed applicabili tramite dei magneti alla struttura è possibile customizzare in maniera differente ogni lampada. Viene fornita con sistema di illuminazione integrato, disponibile in due dimensioni e nelle finiture nero opaco e ottone satinato.

Moonlight is a collection of lamps with a strong graphic connotation.

Choosing between three different designs of shaped metal sheets and applicable by means of magnets to the structure you can customize each lamp in a different way. Comes with integrated lighting system, available in two sizes and in matt black and satin brass finishes.



7327/A1

7327/2



7327/1

MOONLIGHT

Lampadina
Light bulb

STRIP LED
10/ 14/ 28 W
3000°K



Metallo
Metal

V0199
Nero opaco
Matt black

V2805
Ottone satinato
Satin brass

Diffusore
Diffuser

Plexiglass

Maschere disponibili
Available masks

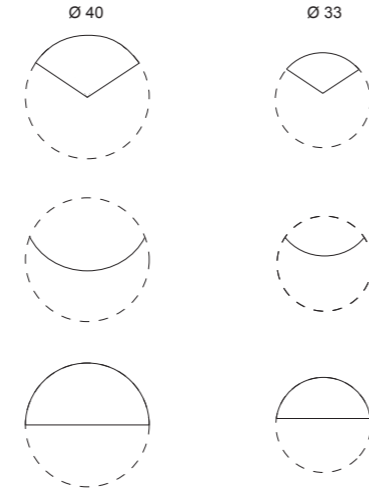

Art. 7327/1 Ø33

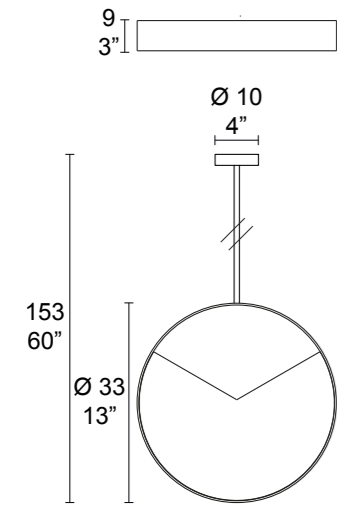

Art. 7327/1 Ø40

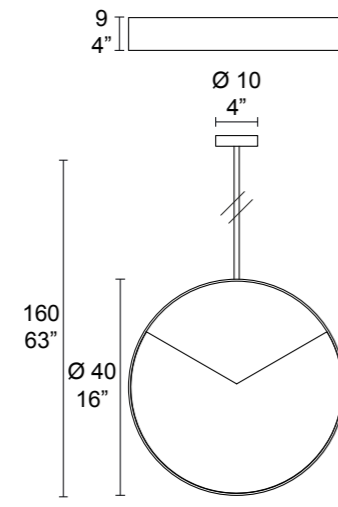

Art. 7327/2

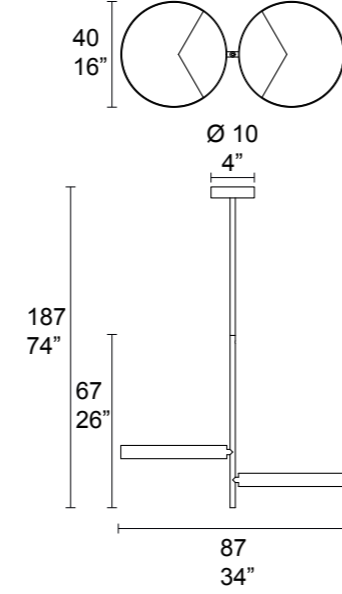

Art. 7327/A1 Ø33

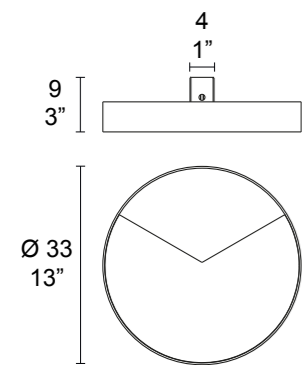

Art. 7327/A1 Ø40

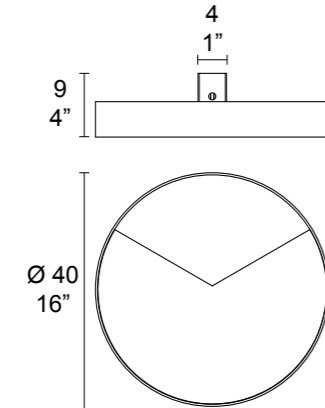

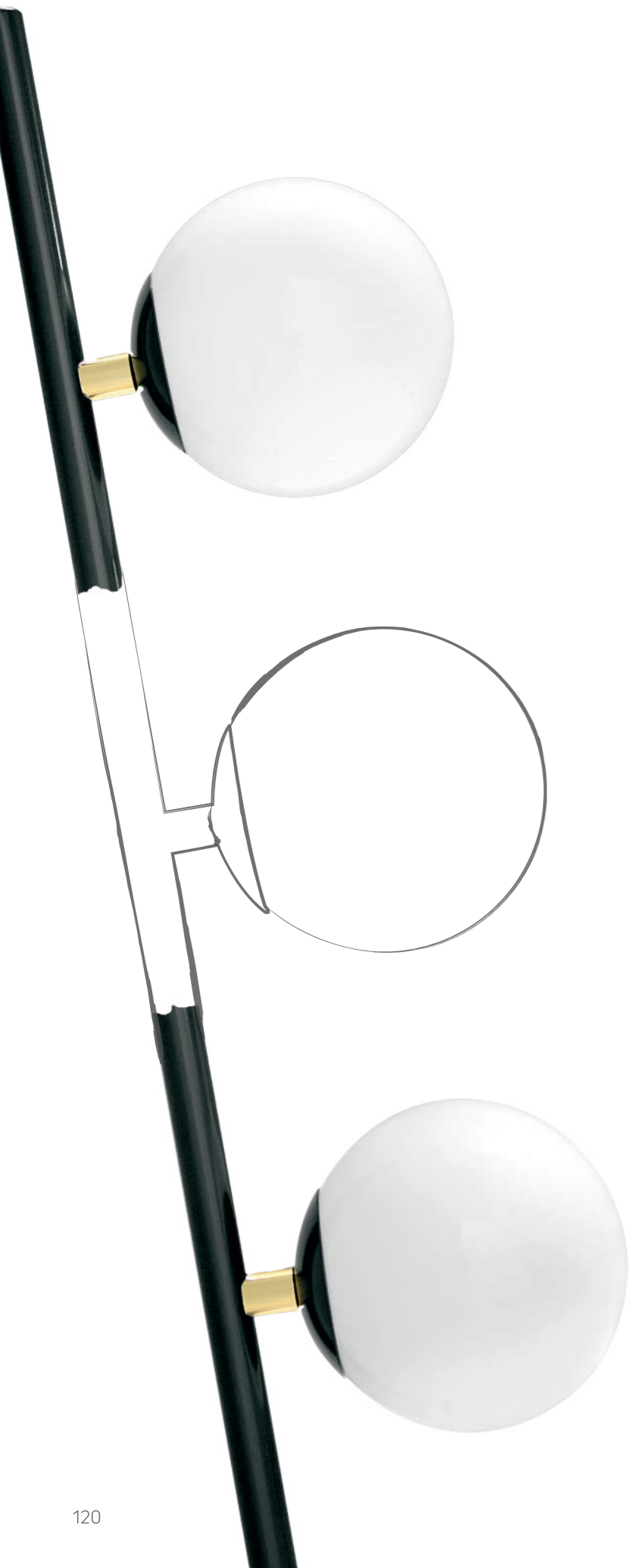

ARCH

MATTEO VALENTI

Una serie dalle linee essenziali, pulite e slanciate. Un'eleganza anni 70 che si esprime nei dettagli: snelli tubi metallici leggermente ricurvi e sfere in vetro bianco opalino. Da semplici elementi singoli arrivano ad intrecciarsi per creare volumi in perfetto equilibrio. Per la sua conformazione si presta inoltre, per progetti speciali, ad una notevole personalizzazione.

A series with essential, clean and slender lines. A 70's elegance that is expressed in the details: slender slightly curved metal tubes and spheres in white opaline glass. From simple single elements, they can be intertwined to create perfectly balanced volumes. Due to its shape, it is also suitable, for special projects, for a considerable customization.

7252/A2





7252/LT2

7252/2





7252/LT4



7252/8

7252/P6

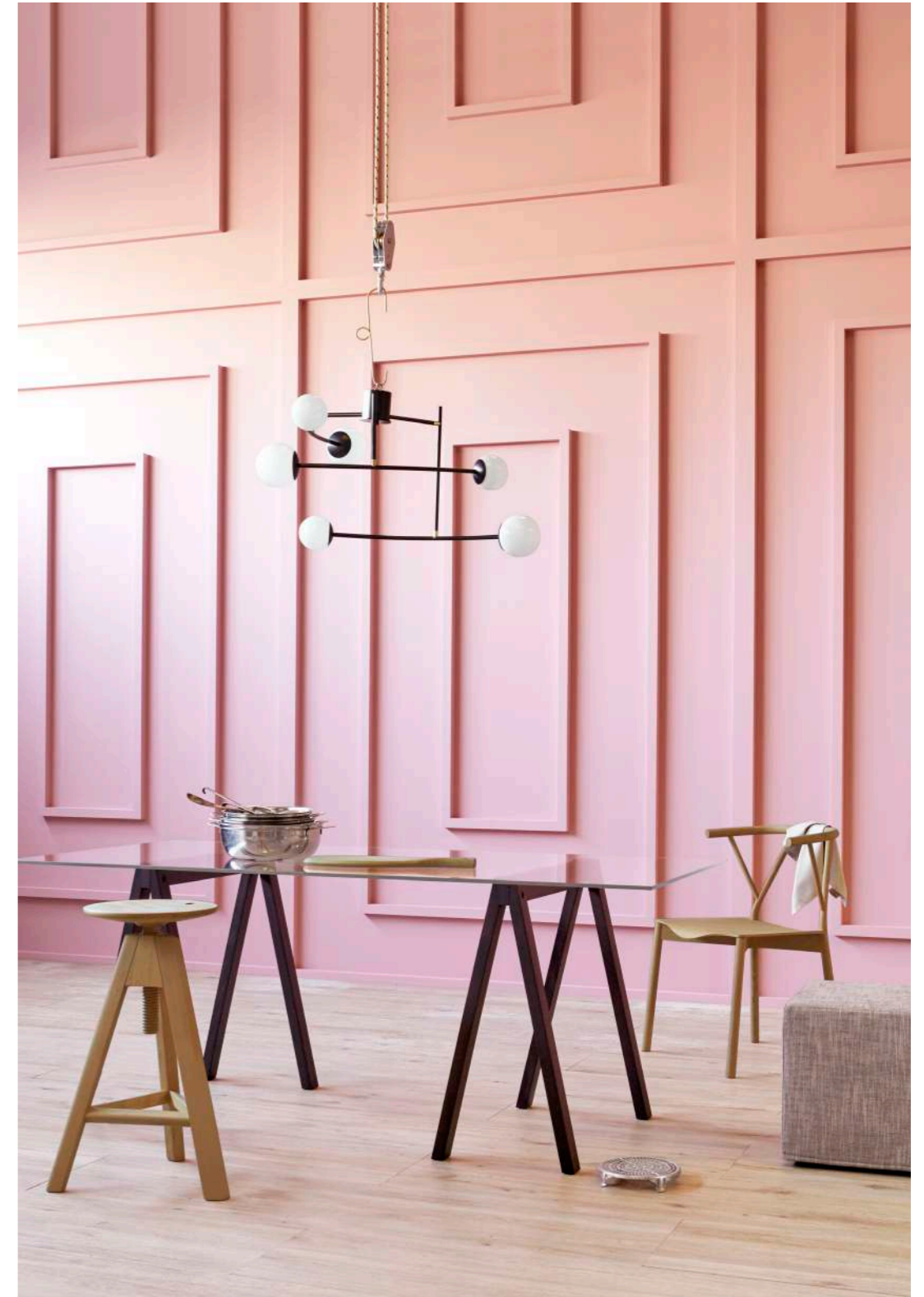

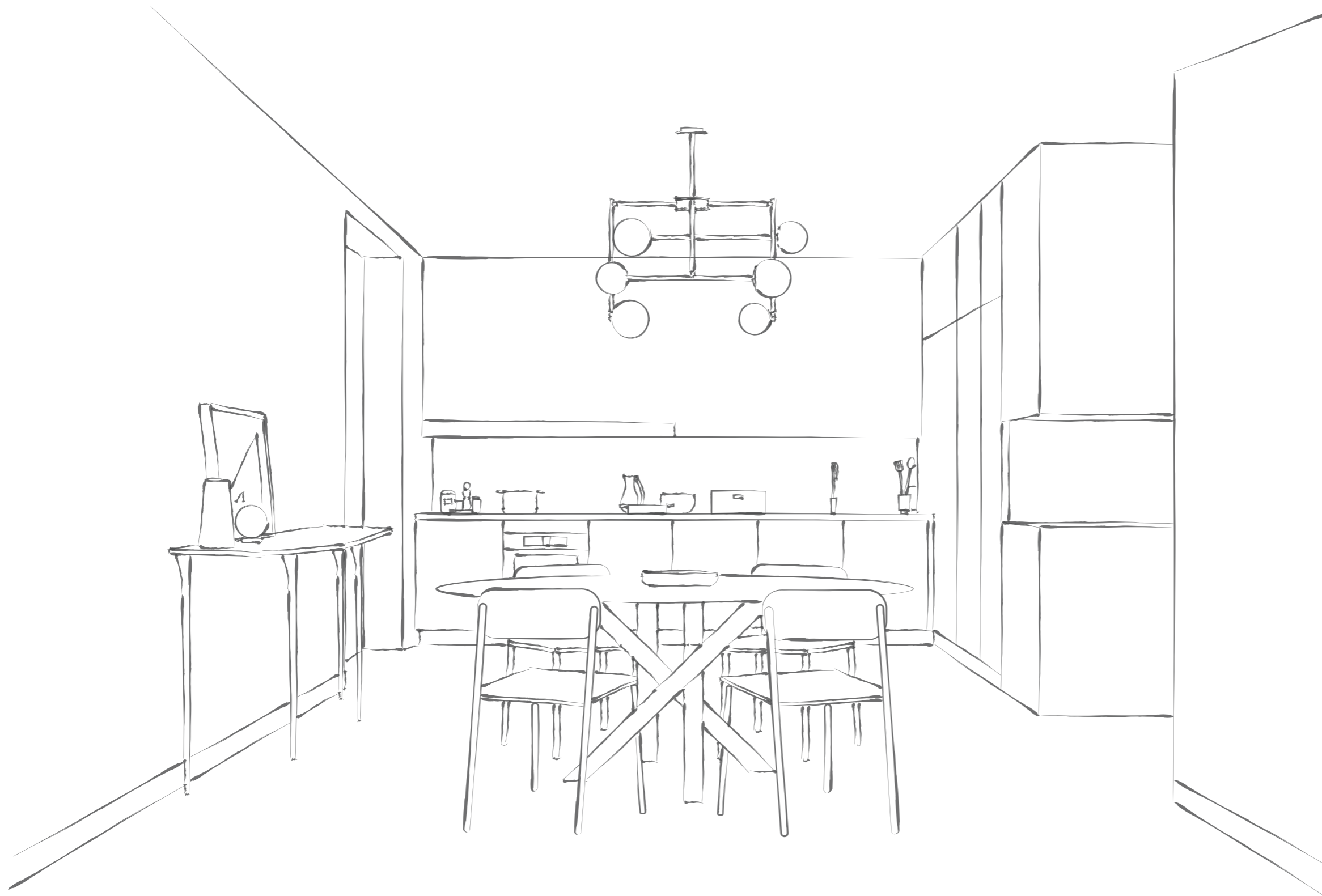

7252/P6

7252/L1





7265/2

7265/LT4

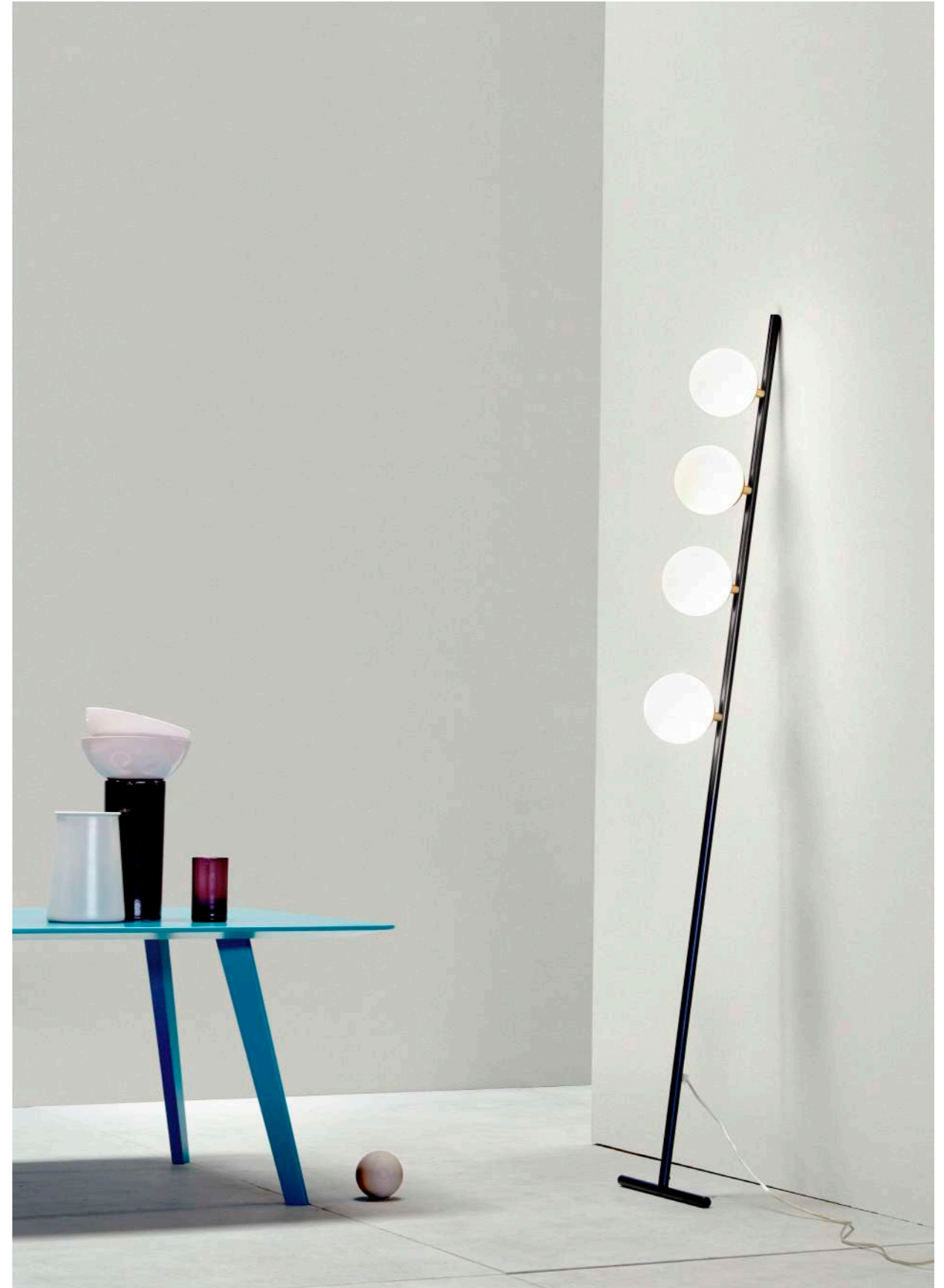



ARCH

Lampadina
Light bulb



Metallo
Metal

- V2828
Canna di fucile
Gunmetal grey
- V2832
Canna di fucile
con particolari in
ottone lucido
Gunmetal grey
with glossy
brass details
- V0216
Ottone lucido
Glossy brass

Vetro
Glass

- Bianco lucido
Glossy white

Art. 7252/1

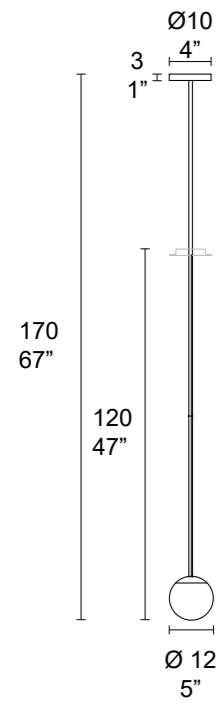

Art. 7252/A1 G

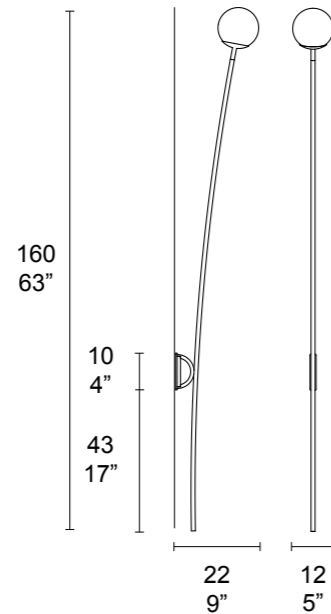

Art. 7265/LT4

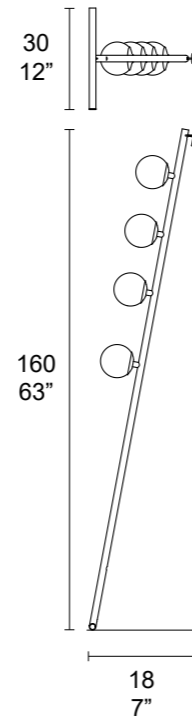

Art. 7252/2

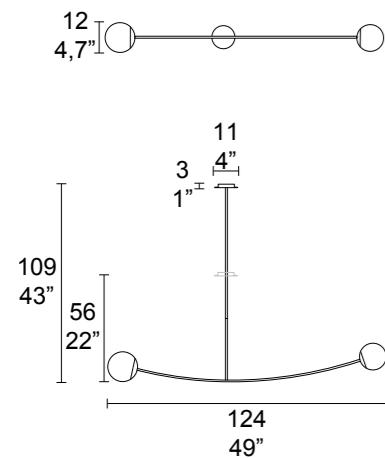

Art. 7252/L1

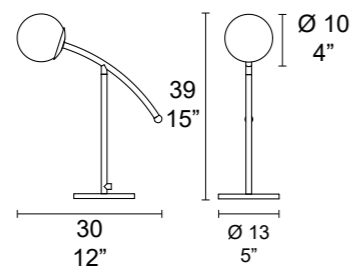

Art. 7252/A2

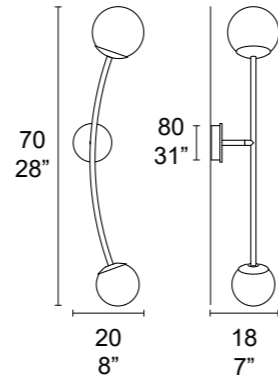

ARCH

Art. 7252/LT2

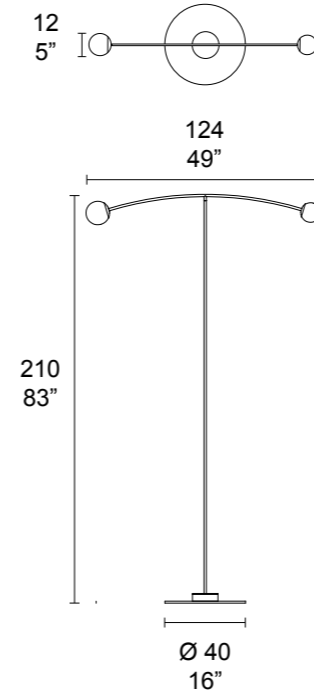

Art. 7252/LT4

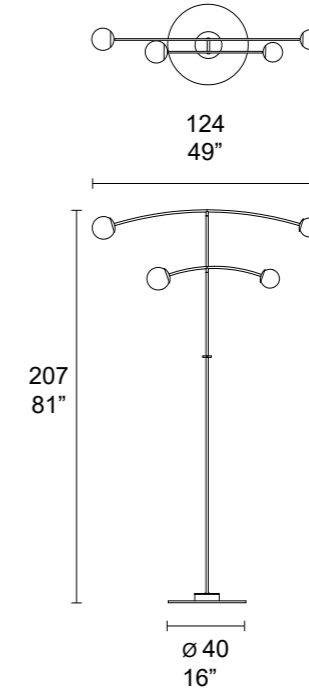

Art. 7265/2

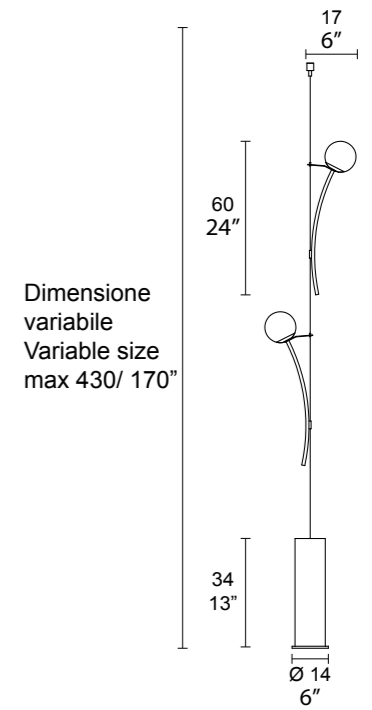

Dimensione
variabile
Variable size
max 430/ 170"

Art. 7252/8

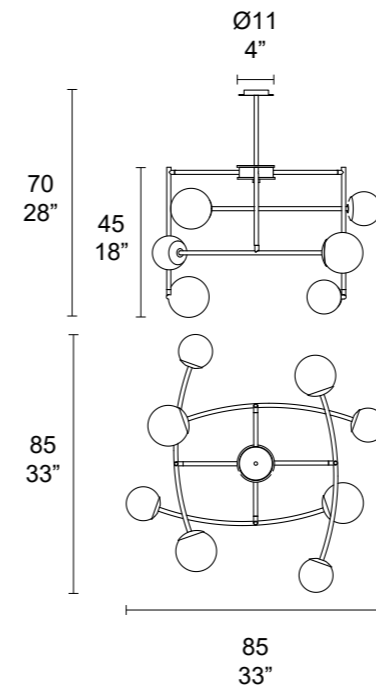

Art. 7252/P6

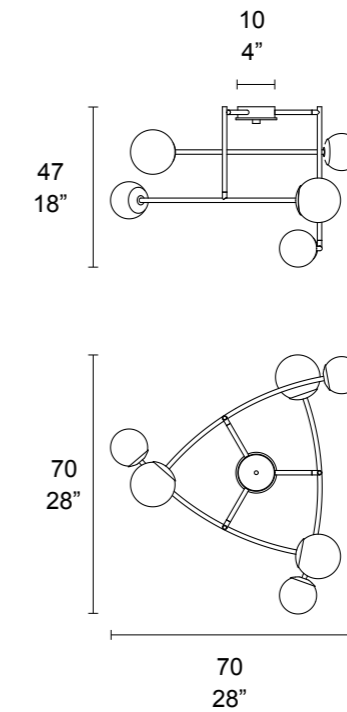



PILL

MATTEO ZORZENONI

Questa serie di lampade è un omaggio alle antiche tecniche di lavorazione del vetro di Murano. La parte superiore con soffiatura su stampo e la parte inferiore con soffiatura a mano libera in gabbia metallica eseguita da Maestri vetrai. Connubio indissolubile tra la struttura in metallo e il vetro di Murano che sembrano abbracciarsi e quasi fondersi in un'unica entità e produrre un effetto etereo e di estrema eleganza.

This series of lamps is a tribute to the ancient techniques of working with Murano glass. The upper part is blown on a mould and the lower part is blown by hand in a metal cage by master glassmakers. An indissoluble union between the metal structure and the Murano glass that seem to embrace and almost merge into a single entity and produce an ethereal effect of extreme elegance.

7237/L1



7237/A1



7237/2

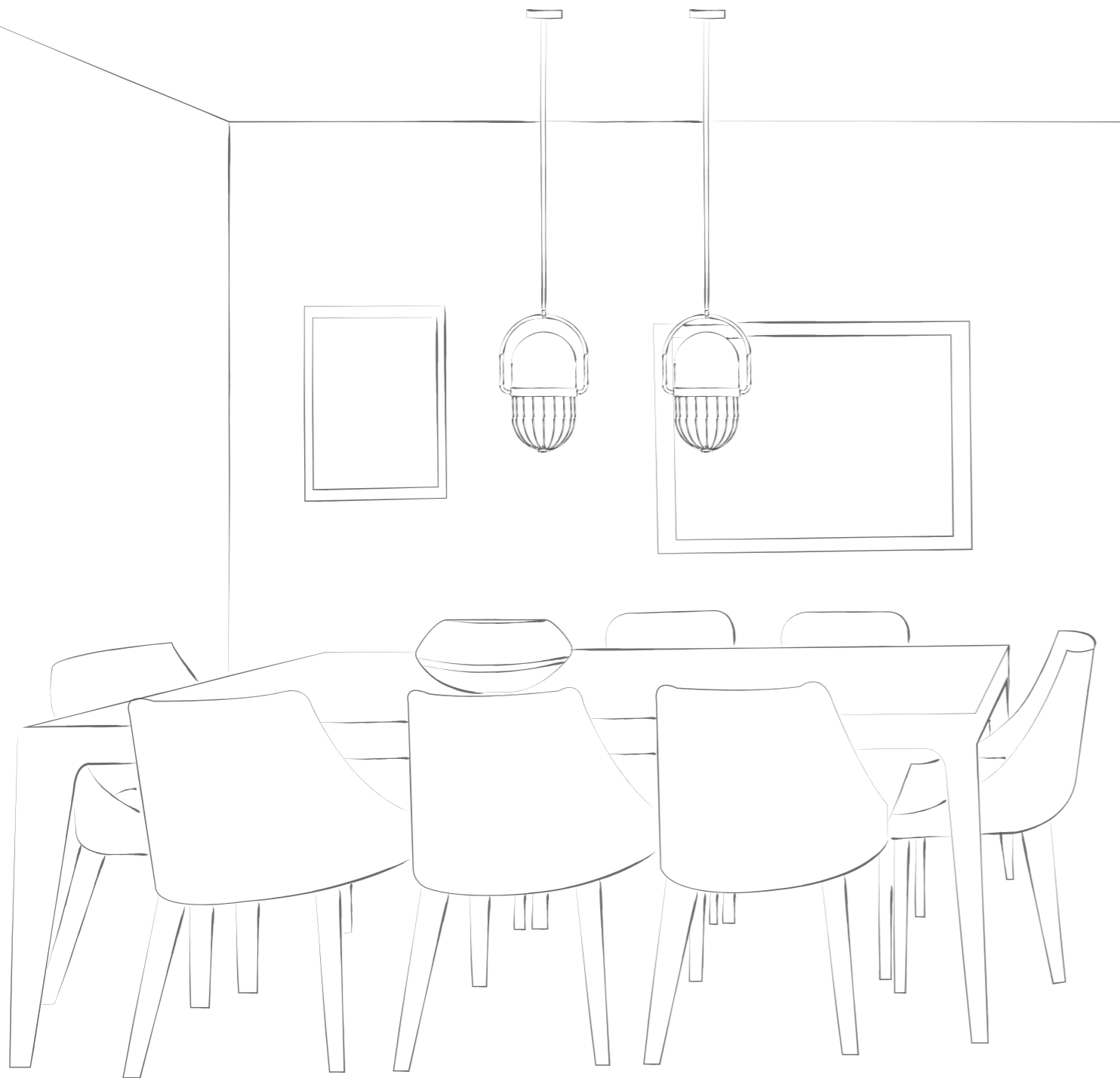

7237/2





7237/LT1

PILL

Lampadina
Light bulb



Metallo
Metal

V0197
Oro 24K
Gold 24K

Vetro
Glass

Vetro fumé
Fumé glass

Vetro ambra
Amber glass

Art. 7237/2

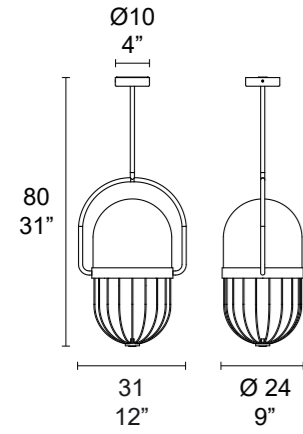

Lampadina
Light bulb



Metallo
Metal

V0197
Oro 24K
Gold 24K

Vetro
Glass

Vetro fumé
Fumé glass

Vetro ambra
Amber glass

Art. 7237/LT1

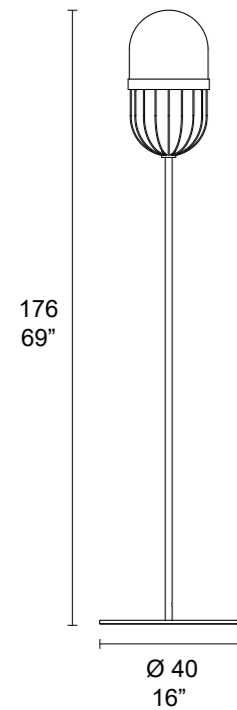

PILL

Lampadina
Light bulb



Metallo
Metal

V0197
Oro 24K
Gold 24K

Vetro
Glass

Vetro fumé
Fumé glass

Vetro ambra
Amber glass

Art. 7237/L1

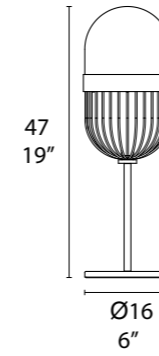

Art. 7237/A1

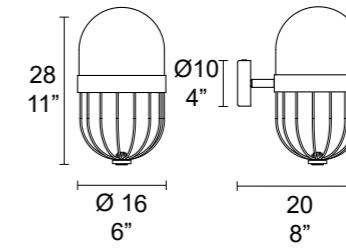



BALLOTON

MATTEO ZORZENONI

Balloton riporta alla luce la tecnica veneziana del soffiaggio del vetro e la reinterpreta in questa suggestiva collezione di lampade in metallo. Moduli disponibili singolarmente o in grandi composizioni a "chandelier", disponibili ora anche nella versione mini che è adattabile a plafoni già in uso per altre gamme di prodotto.

Balloton brings to light the Venetian technique of glass blowing and reinterprets it in this evocative collection of metal lamps. Modules available individually or in large "chandelier" compositions, now also available in the mini version that can be adapted to ceilings already in use for other product ranges.

7211/LT1



7213/L1



7211/A1



7212/1 ACORN

7211/1 DISK

7213/1 PILL



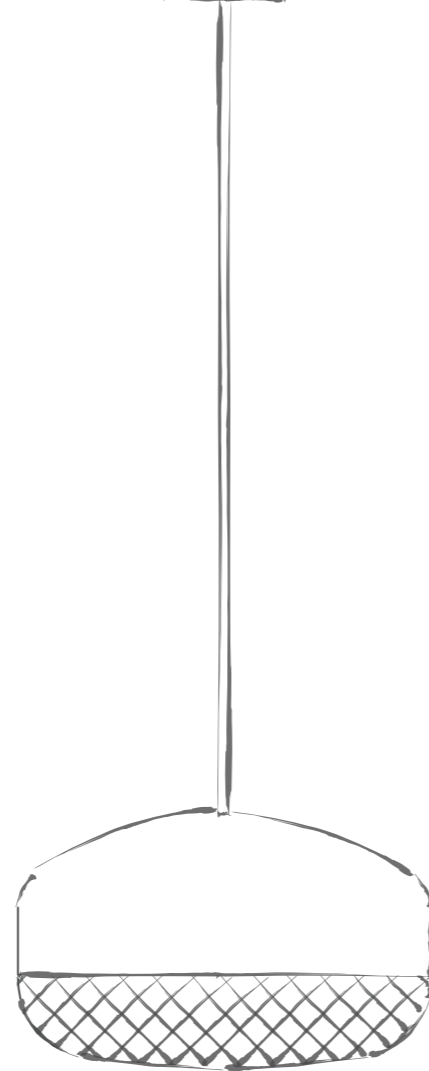
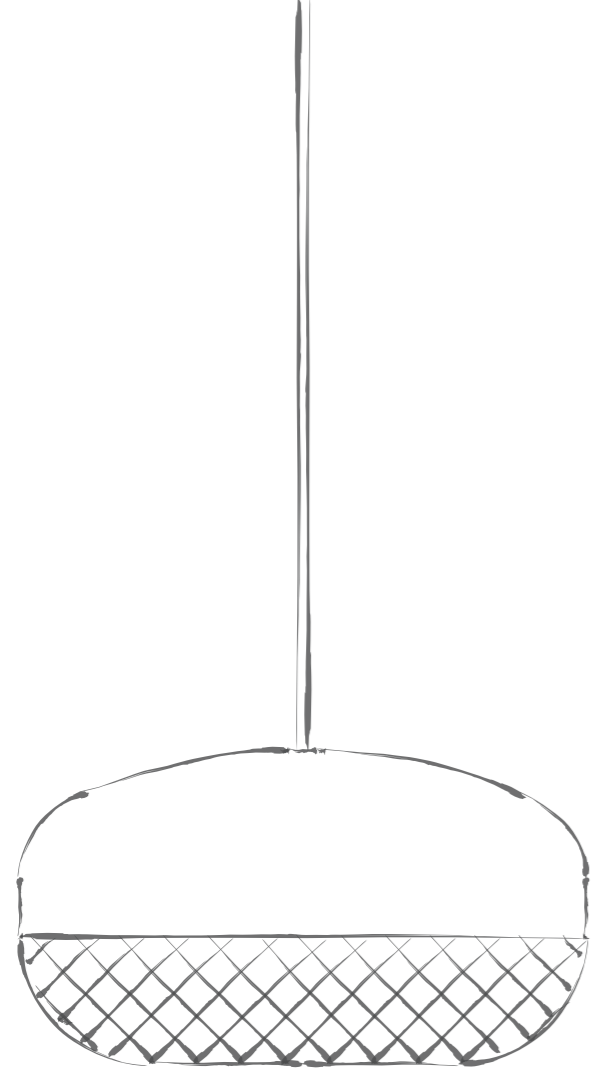

La famiglia cresce e si fa più piccola.
Ora Balloton anche mini.

The family grows and gets smaller.
Now mini Balloton.



7212/1 ACORN MINI

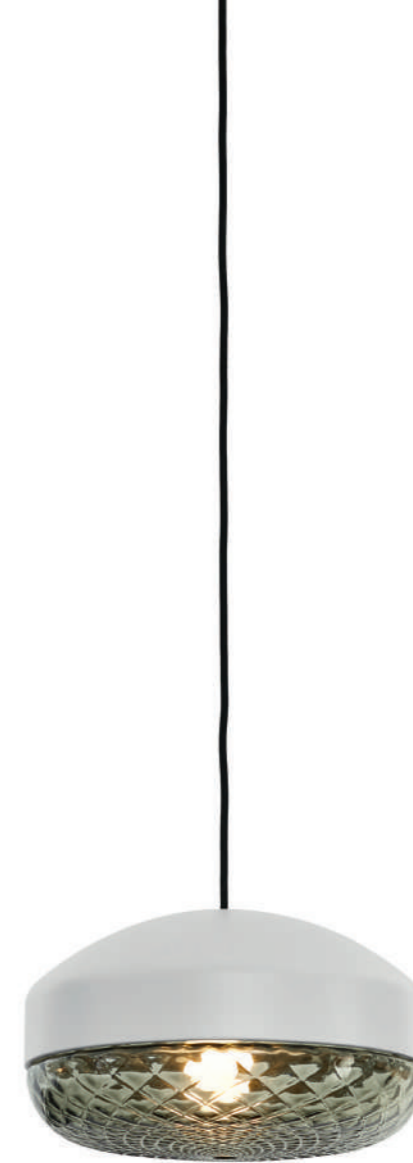

7211/1 DISK MINI



7213/1 PILL MINI

La famiglia Balloton Mini è disponibile con il vetro Balloton , Balloton Fumè e Vetro liscio bianco sfumato.

The Balloon range is available with Balloton glass, fumé and white smooth glass.





7212/1 ACORN MINI



7212/



7212/

BALLOTON

Lampadina
Light bulb



Metallo
Metal

- V0199
Nero opaco
Matt black
- V2907
Bianco Opaco
Matt White
- V2806
Rame lucido
Glossy copper

Vetro
Glass



Art. 7211/1 DISK

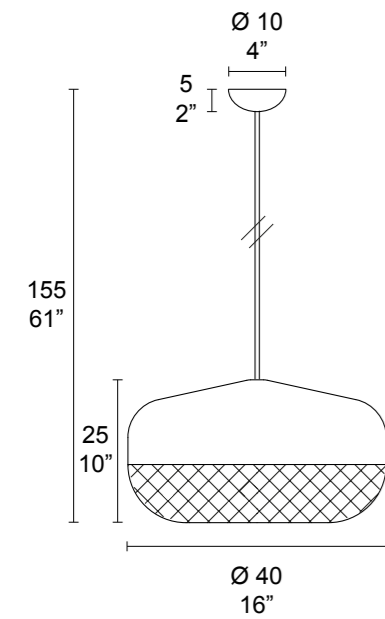

Art. 7212/1 ACORN

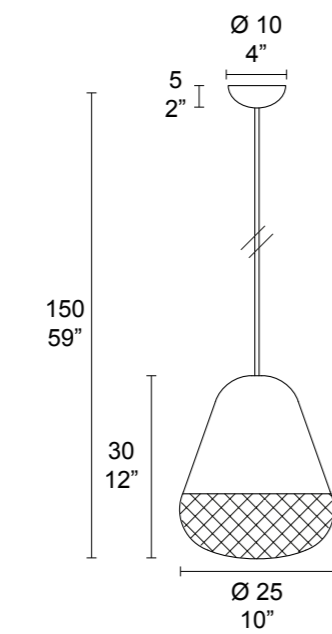

Art. 7213/1 PILL

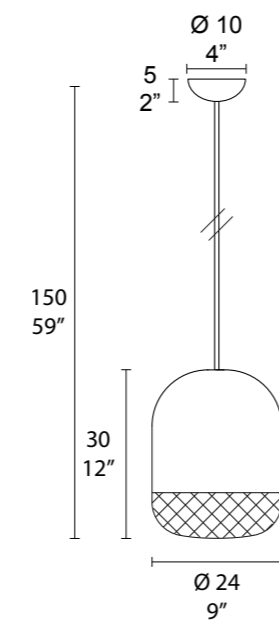

Art. 7211/A1

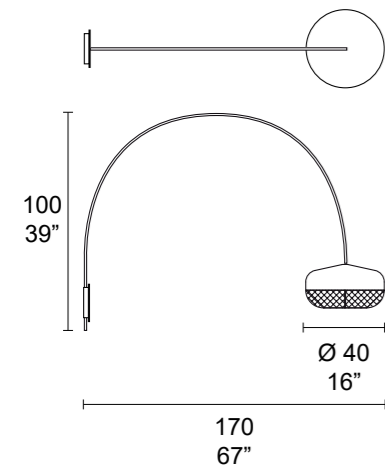

Art. 7211/LT1

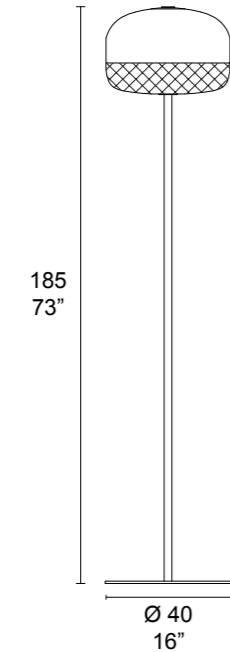

BALLOTON MINI

Lampadina
Light bulb



Metallo
Metal

- V0199
Nero opaco
Matt black
- V2907
Bianco Opaco
Matt White
- V2806
Rame lucido
Glossy copper

Vetro
Glass

- Balloton
- Balloton Fumé
Smoked balloton
- Vetro liscio
Smooth glass

NEW

Art. 7211/1 DISK MINI

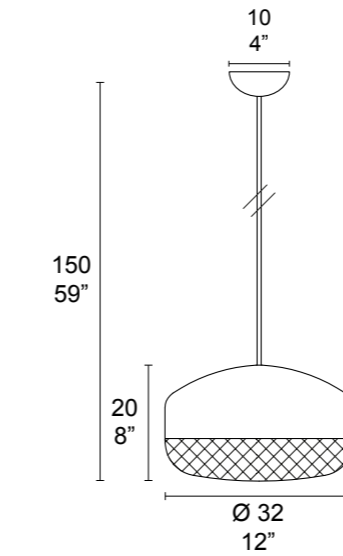

NEW

Art. 7212/1 ACORN MINI

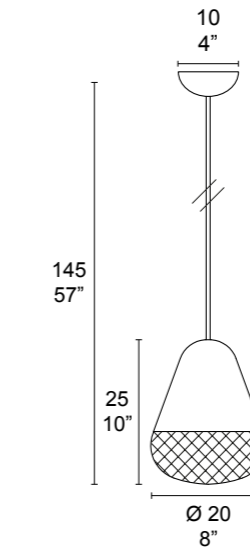

NEW

Art. 7213/1 PILL MINI

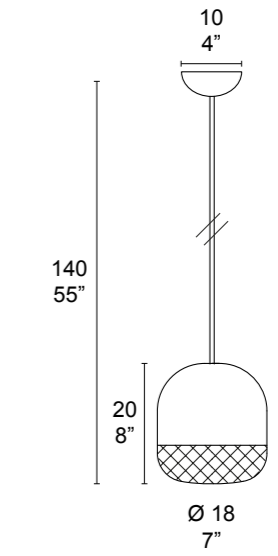

NEW

Art. 7213/A1 ACORN MINI

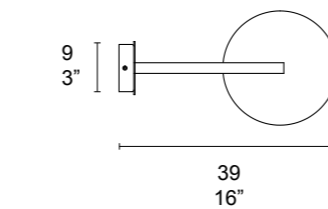

NEW

Art. 7213/A1 PILL MINI

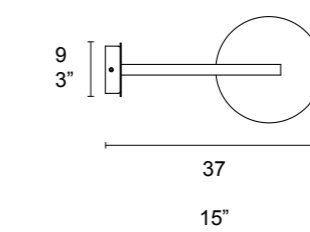

Lampadina
Light bulb



Metallo
Metal

- V0199
Nero opaco
Matt black
- V2806
Rame lucido
Glossy copper

Vetro
Glass



NEW

Art. 7213/L1 MINI Art. 7213/L1

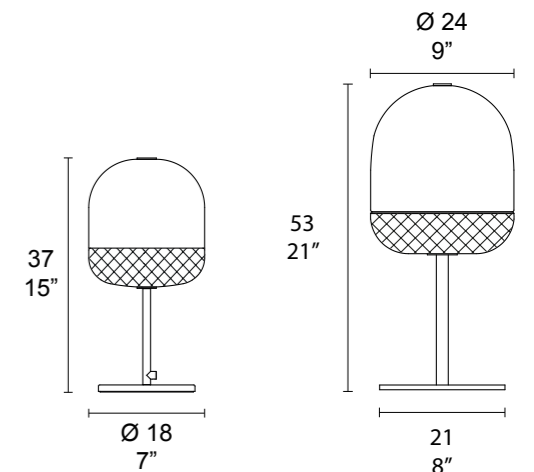

RAYS

MATTEO ZORZENONI



Chiamata così per la rifrazione della luce donata dal vetro classico di Murano, Rays con la sua struttura in metallo circolare e top in vetro soffiato effetto balloton sostenuto da bracci radiali reinterpreta in chiave contemporanea lo stile essenziale e di ricerca del medioevo che faceva della luce il principale elemento di decorazione di interni.

Named after the refraction of light given by classic Murano glass, Rays, with its circular metal structure and top in blown glass with a balloton effect supported by radial arms, reinterprets in a contemporary way the essential style and research of the Middle Ages that made light the main element of interior decoration.

7209/L3

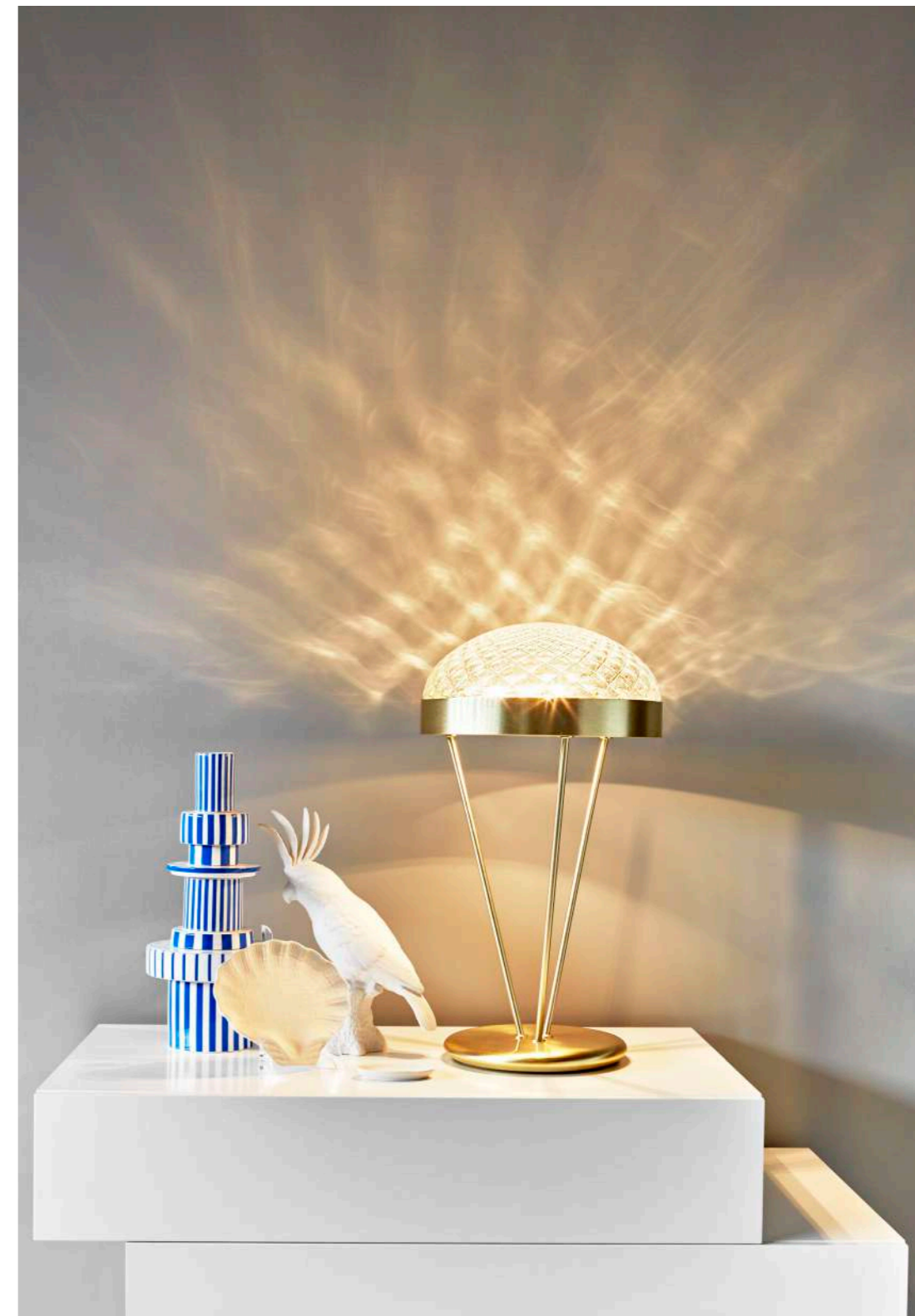



7209/P3

7209/3



RAYS

Lampadina
Light bulb



Metallo
Metal

V0199
Nero opaco
Matt black

V2805
Ottone satinato
Sat brass

Vetro
Glass

Cristallo balloton
Crystal balloton

Art. 7209/3

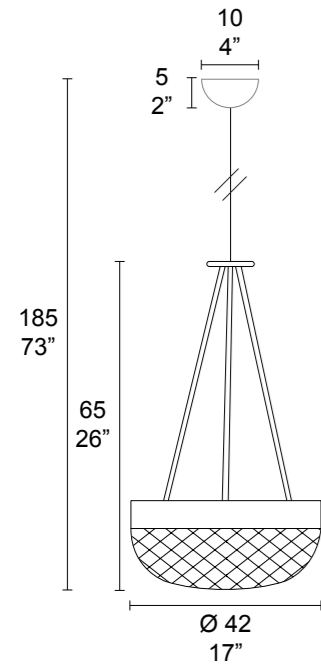

Art. 7209/L3

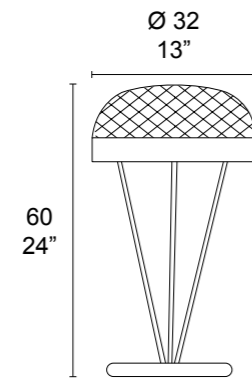

Art. 7209/P3

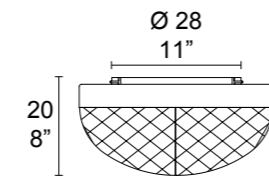

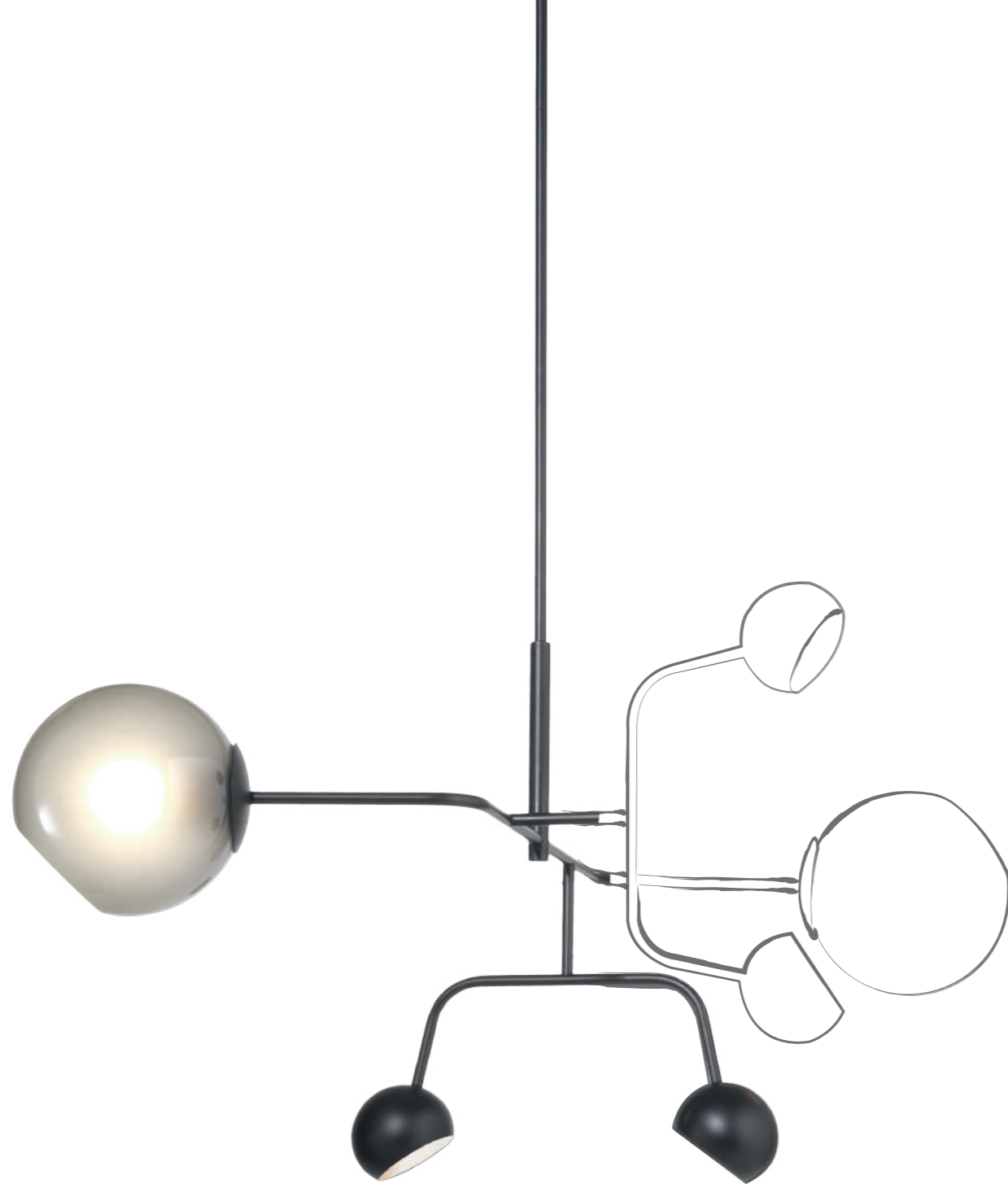

CHILL

MASSIMO ZAZZERON

Chill evoca le linee fluide e semplici dell'arte e del design, dove la grafica si fonde alla semplicità delle forme. Le strutture in metallo verniciato opaco sostengono sfere metalliche con illuminazione a led direzionabili e boule di vetro soffiato muranese che permettono differenti modalità di illuminazione, diffusa e puntuale.

7330/A2



Chill evokes the fluid and simple lines of art and design, where graphics blend with the simplicity of forms. The structures in opaque painted metal, support metal spheres with directional Led lighting and Murano blown glass boules that allow different modes of lighting, diffused and punctual.

7330/6

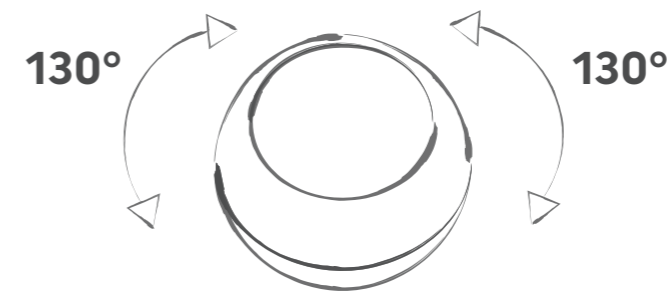
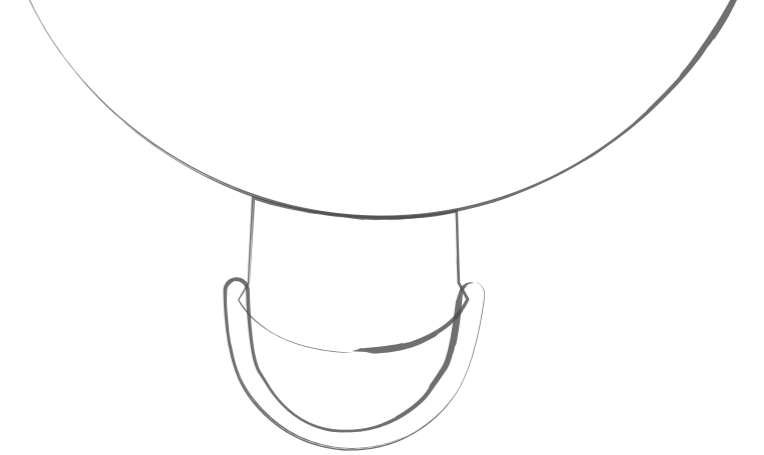

Le sfere in metallo della famiglia Chill possono essere ruotate per una luce direzionale.

The metal spheres of the Chill family can be rotated for directional lighting.

CHILL

Lampadina
Light bulb



42W E27
non include
not included



LED
LED BOARD 4,5W
3000 K
include
included



Metallo
Metal



V0199
Nero opaco
Matt black



V2907
Bianco opaco
Matt white

Vetro
Glass



Fumé satinato
Satin fumé

+



PMMA opale
Ice white

Art. 7330/6

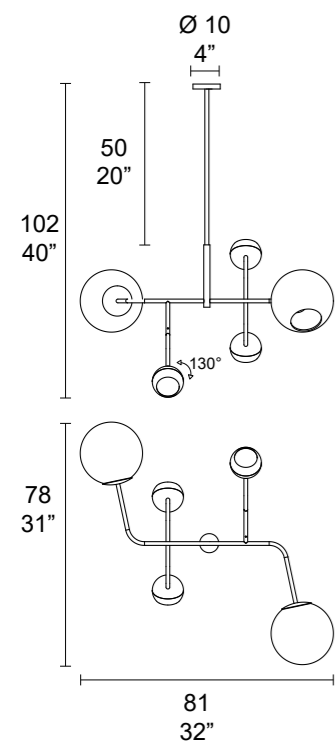

Art. 7330/A2

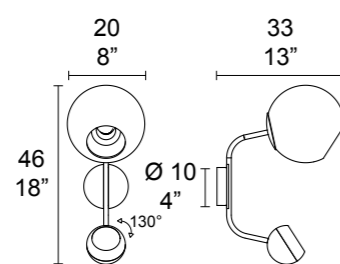

PAPILLON

MATTEO ZORZENONI



Le forme fluide dei tubi metallici lavorati ad arte di questo "chandelier" vogliono ricordare il papillon, accessorio dell'abbigliamento classico. Come il simbolo di eleganza ed icona di stile sin dalla fine del XIX secolo queste lampade arredano e completano l'immagine dell'ambiente in cui sono inserite donandole un tocco di ricercatezza.

The fluid shapes of the metal tubes worked to art of this "chandelier"; want to remember the bow tie, accessory of the classic clothing. As the symbol of elegance and style icon since the end of the 19th century, these lamps furnish and complete the image of the environment in which they are placed, giving it a touch of sophistication.

7207/12



7207/8

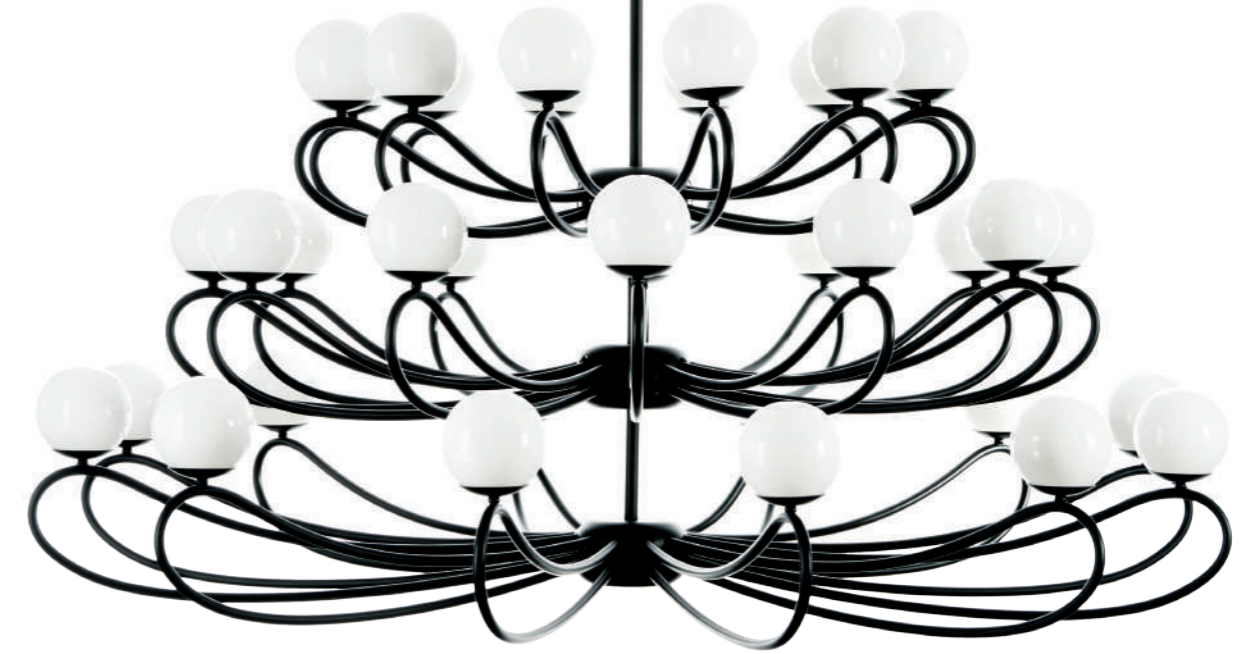

7207/36

PAPILLON

Lampadina
Light bulb



Metallo
Metal

- V0199
Nero opaco
Matt black
- V0216
Ottone lucido
Glossy brass

Vetro
Glass

- Vetro bianco
White glass

Art. 7207/12 Ø120

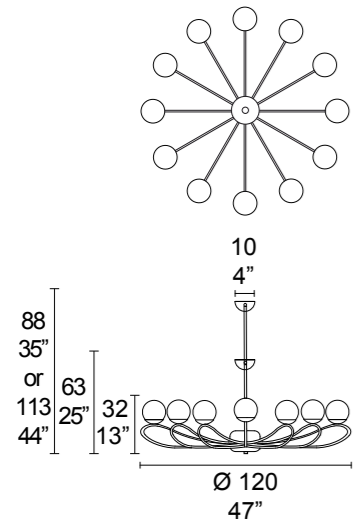

Art. 7207/12 Ø90

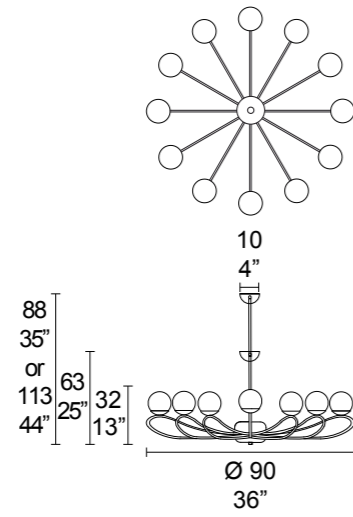

Art. 7207/8

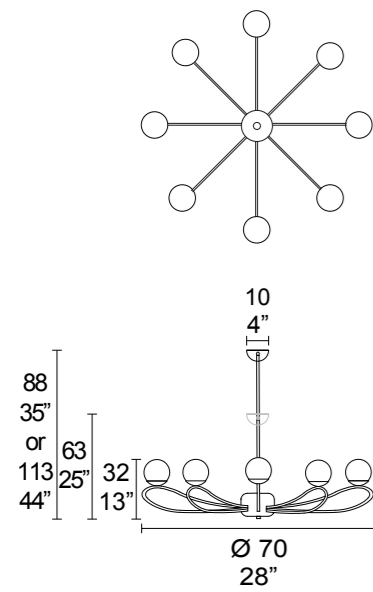

Art. 7207/36

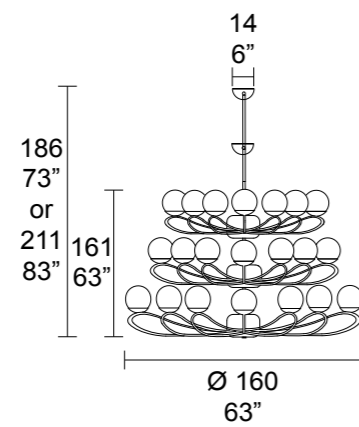

DOTS

MATTEO ZORZENONI

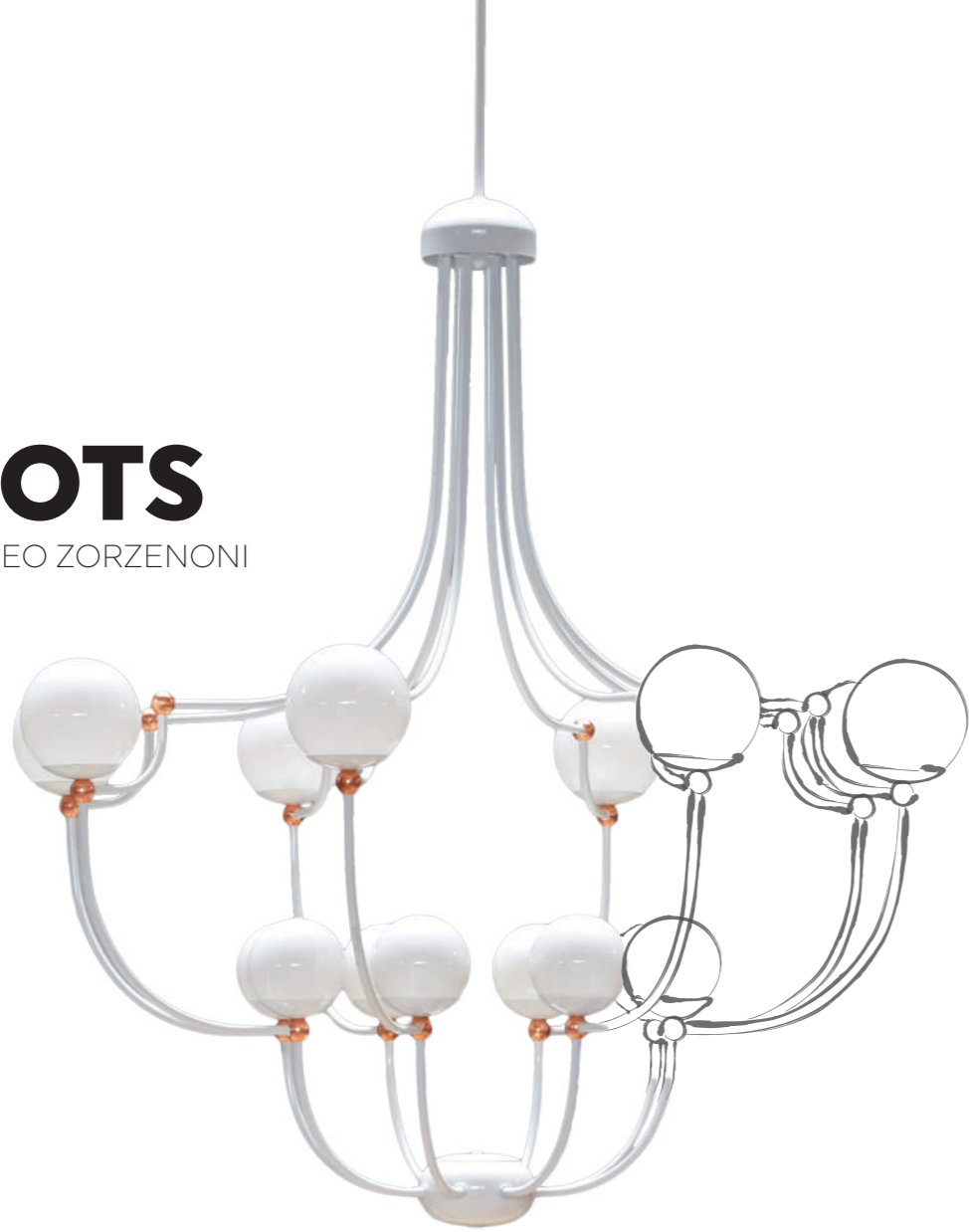

Dots è la nuova reinterpretazione di un prodotto Classico di Maison MM, sottoposto ad una ricerca di semplicità tesa ad eliminare ogni elemento non necessario. Ciò che ne rimane è "l'anima" della struttura in metallo di cui sono stati fatti risaltare gli snodi di contatto. A sottolinearne le linee arrotondate e delle sfere in vetro bianco opalino.

Dots is the new reinterpretation of a Classic product by Maison MM, subjected to a search for simplicity aimed at eliminating any unnecessary element. What remains is the "soul" of the metal structure of which the contact joints have been highlighted. To underline the rounded lines and spheres in white opal glass.



7210/A1

7210/A2

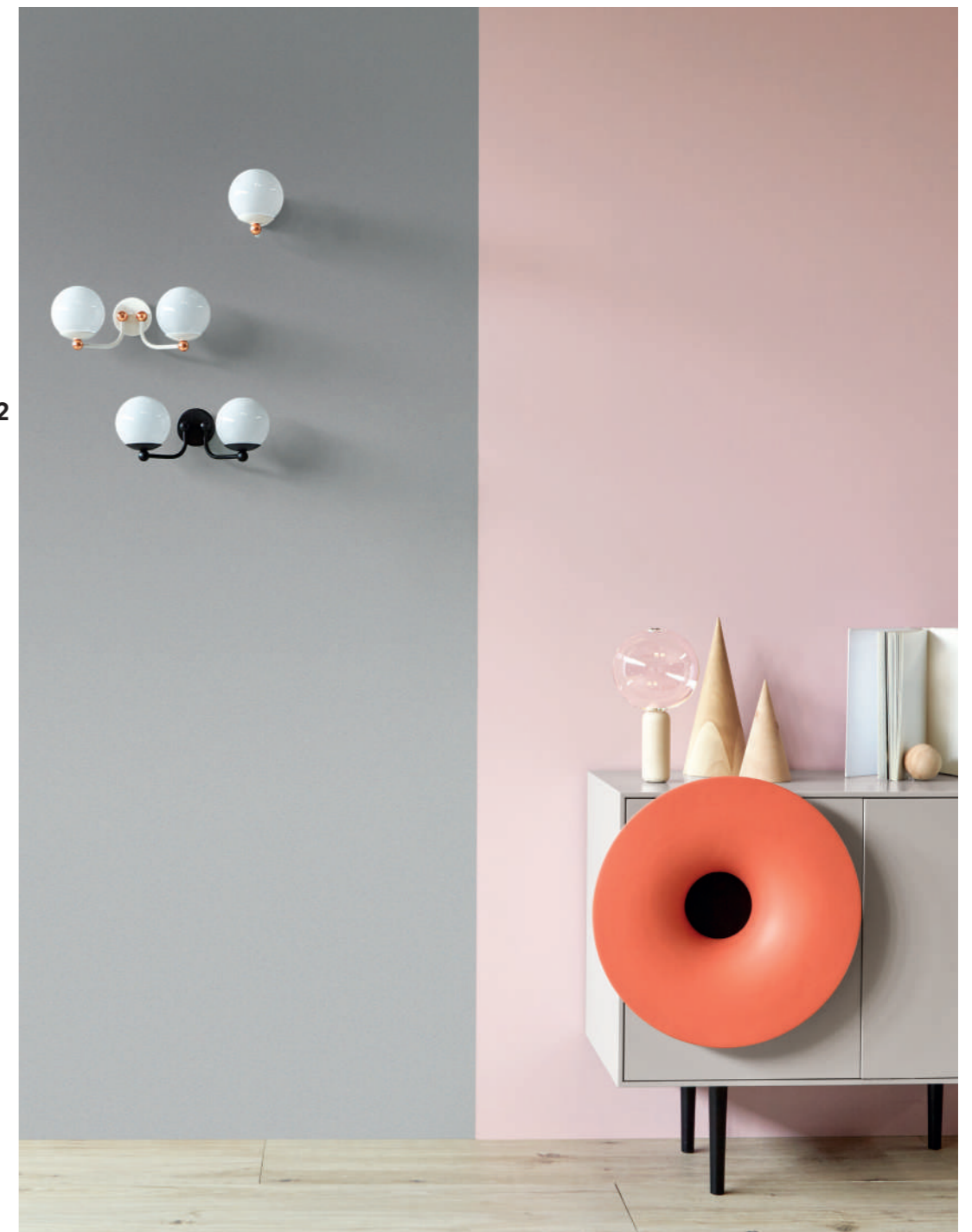

7210/16

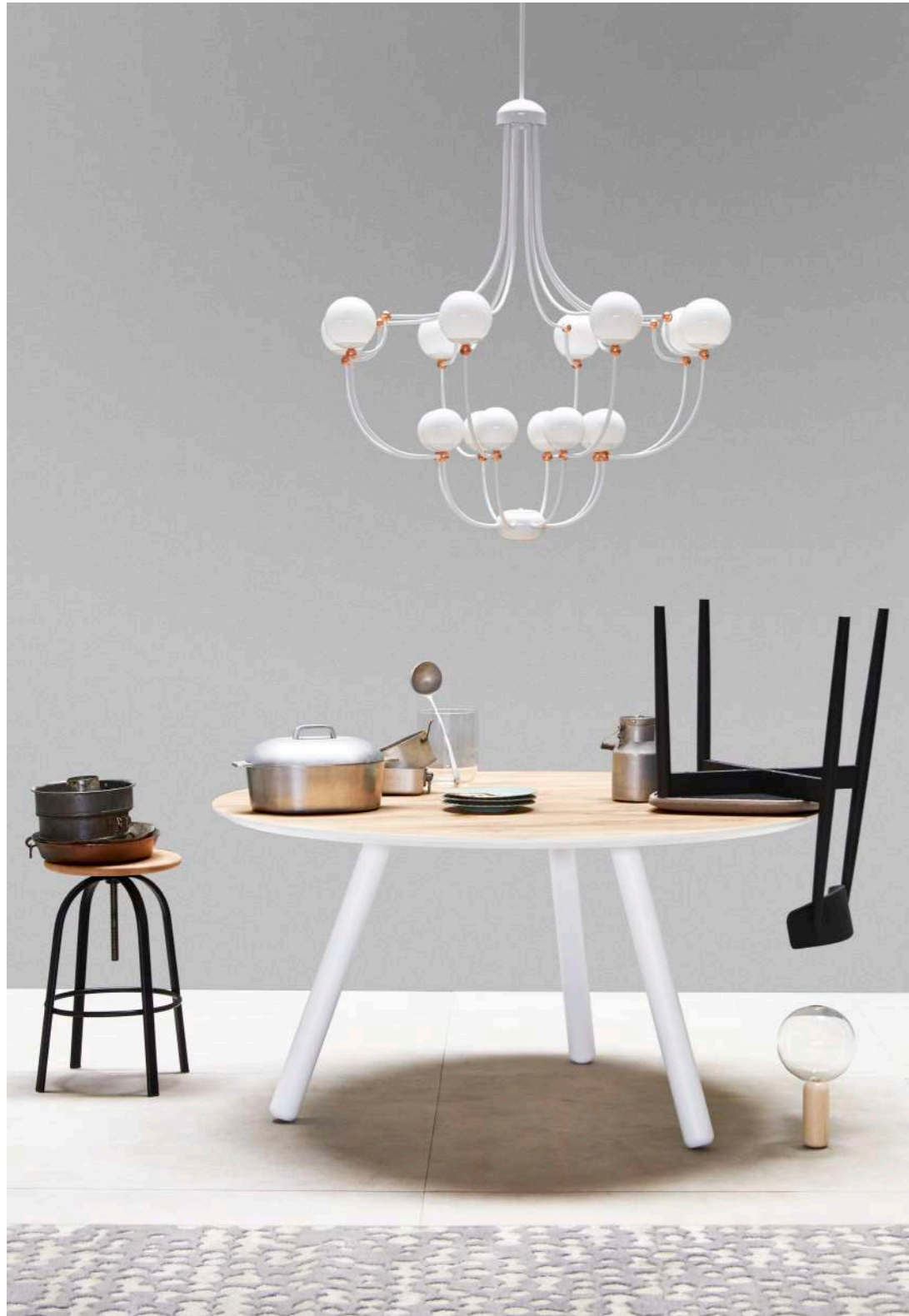

7210/P7

7210/P6

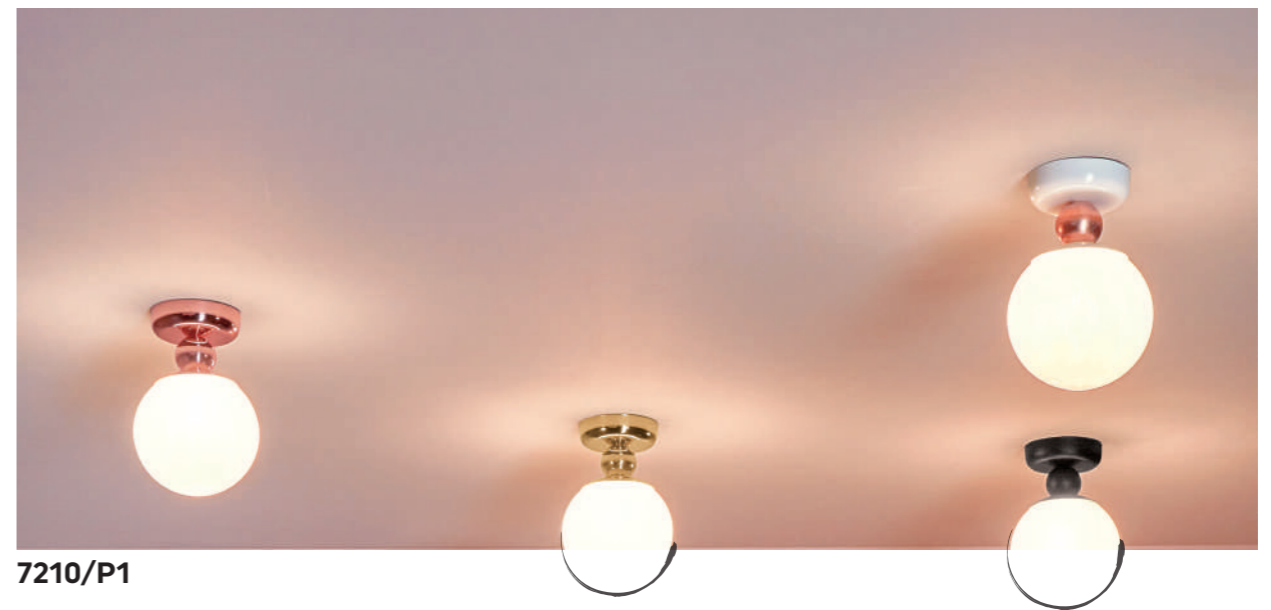

7210/P1

7210/LT5

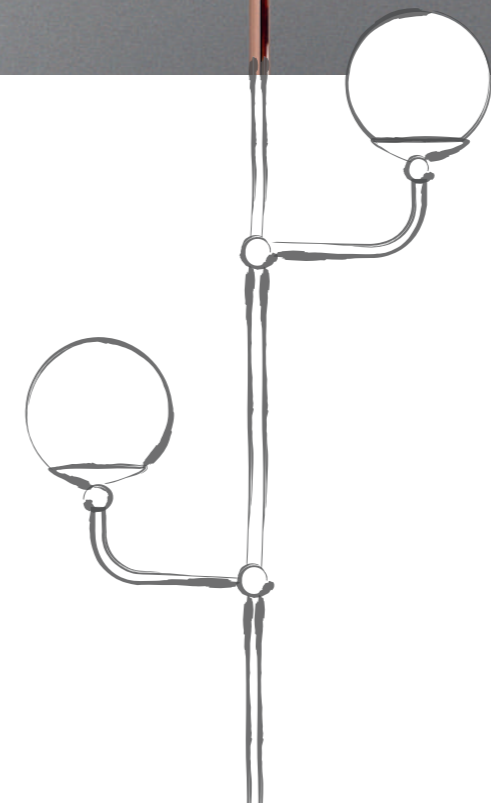

DOTS

Lampadina
Light bulb



Metallo
Metal

- V2821
Nero opaco con
dettagli foglia oro
Matt black with
gold leaf details
- V2809
Bianco lucido con
particolari in
foglia rame
Glossy white with
copper leaf details
- V2824
Ottone opaco
Matt brass
- V2806
Rame lucido
Glossy copper
- V0216
Ottone lucido
Glossy brass

Vetro
Glass

- Vetro bianco
White glass

Art. 7210/16

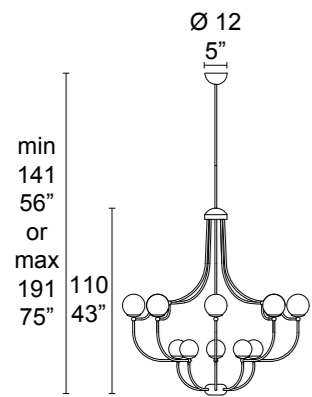
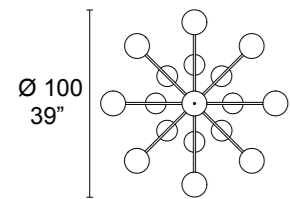

NEW

Art. 7210/14

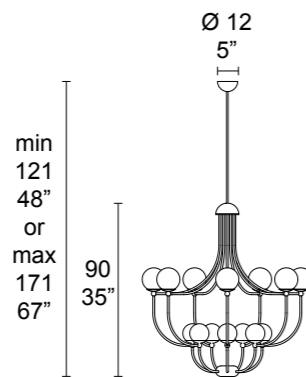
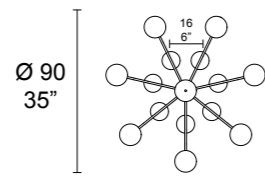

Art. 7210/A1

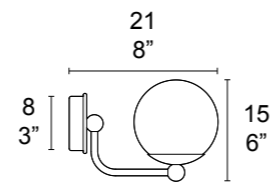

DOTS

Art. 7210/A2

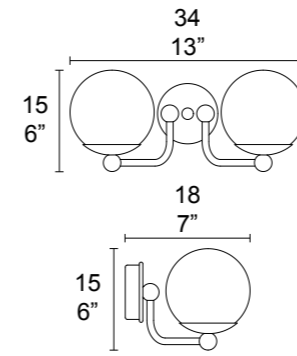

Art. 7210/LT5

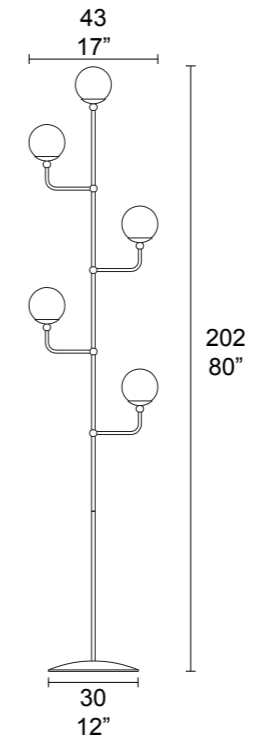

Art. 7210/P1

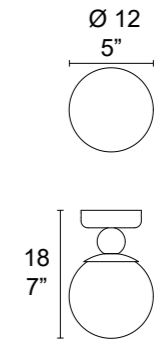

Art. 7210/P6

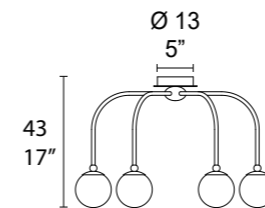
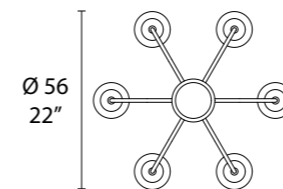

Art. 7210/P7

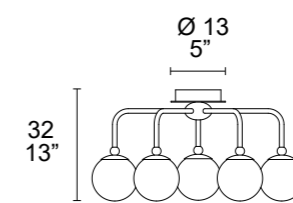
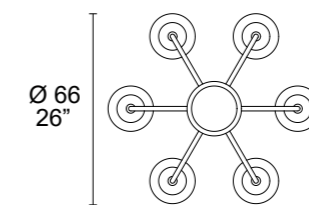



7206/1G

BALLOON

MATTEO ZORZENONI

Balloon prende spunto da un prodotto già presente nel catalogo classico. Rivisto e ripulito di qualsiasi fronzolo viene presentato in chiave contemporanea, mettendone in risalto la struttura. Presentato nelle finiture nero opaco ed oro zecchino, la base in ceramica accompagna con grazia il paralume in tessuto che nei dettagli ne segue il colore principale. Una elegante luce diffusa ed eterea completa l'eleganza con cui la lampada si presenta già al primo sguardo.

Balloon takes its cue from a product already present in the classic catalog. Revised and cleaned of any frills, it is presented in a contemporary key, highlighting its structure. Presented in matt black and pure gold finishes, the ceramic base gracefully accompanies the fabric lampshade, which in the details follows the main colour. An elegant diffused and ethereal light completes the elegance with which the lamp appears at first glance.

7206/1P



7206/L1 P



BALLOON

Lampadina
Light bulb

1 x max 11W
shape T37
max Ø37mm



Metallo
Metal

V0199
Nero opaco
Matt black

V0197
Oro 24K
Gold 24K

Diffusore
Diffuser

Tessuto
Fabric

Art. 7206/1 G

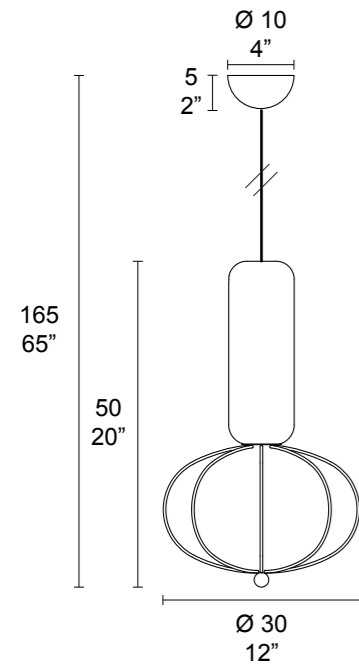

Art. 7206/1 P

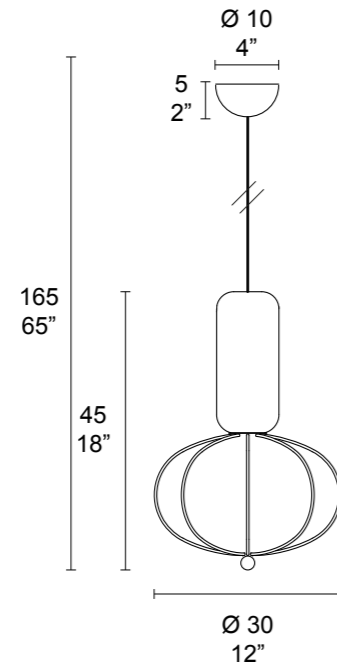

Art. 7206/L1 G

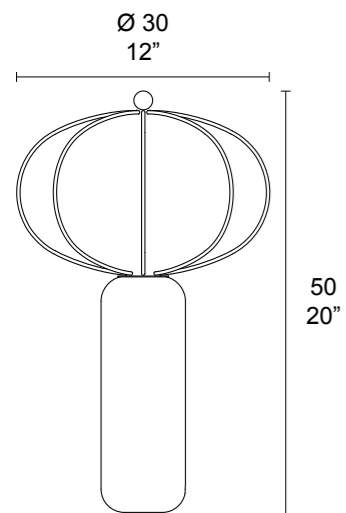

Art. 7206/L1 P

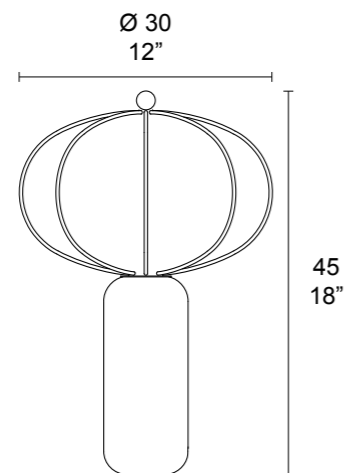



PINEAPPLE

MATTEO ZORZENONI

Il restyling della tradizione artigiana ha dato vita ad una collezione originale e affascinante, dove il vetro lucido di Murano soffiato su stampo del paralume si sposa finemente con la base in ceramica in texture materica romboidale. Disponibile in vari abbinamenti cromatici che lo rendono un elemento decorativo molto pop.

The restyling of the artisan tradition has given life to an original and fascinating collection, where the shiny Murano glass blown on the mould of the lampshade blends finely with the ceramic base in rhomboidal material texture. Available in various color combinations that make it a very pop decorative element.

7214/1





7214/L1



PINEAPPLE

Lampadina
Light bulb



60W E27

Metallo
Metal

Base grigio
RAL 7044
Silk grey base
RAL 7044

Base gialla
RAL 1004
Golden yellow base
RAL 1004

Base turchese
pastello RAL 6034
Turquoise base
RAL 6034

Base blu verdastro
RAL 5001
Green blue base
RAL 5001

Base nero
RAL 9005
Black base
Ral 9005

Vetro
Glass

Vetro tabacco
Tobacco glass

Vetro bianco
White glass

Vetro bianco
White glass

Vetro bianco
White glass

Vetro bianco
White glass

Art. 7214/1

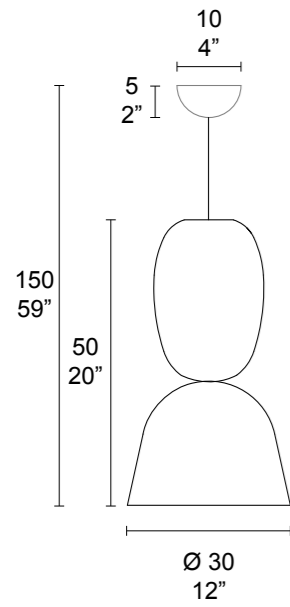

Art. 7214/L1

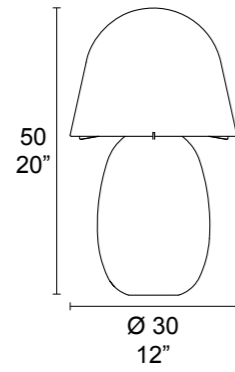

CLOUD

UFFICIO TECNICO MM LAMPADARI

Nasce dalla leggerezza che trasmettono le nuvole l'idea di crearne un connubio con un materiale apparentemente a loro contrario come il metallo. Il risultato è una lampada è composta da lamierine distribuite su più livelli che schermano parte della luce creando suggestivi effetti di luce mantenendo comunque inalterata la sua funzione illuminante per l'ambiente.

The idea of creating a union with a material apparently contrary to them, such as metal, is born from the lightness that clouds transmit. The result is a lamp composed of blades distributed on several levels that shield part of the light creating suggestive light effects while maintaining its function as an illuminant for the environment.



6978/A2



6978/9

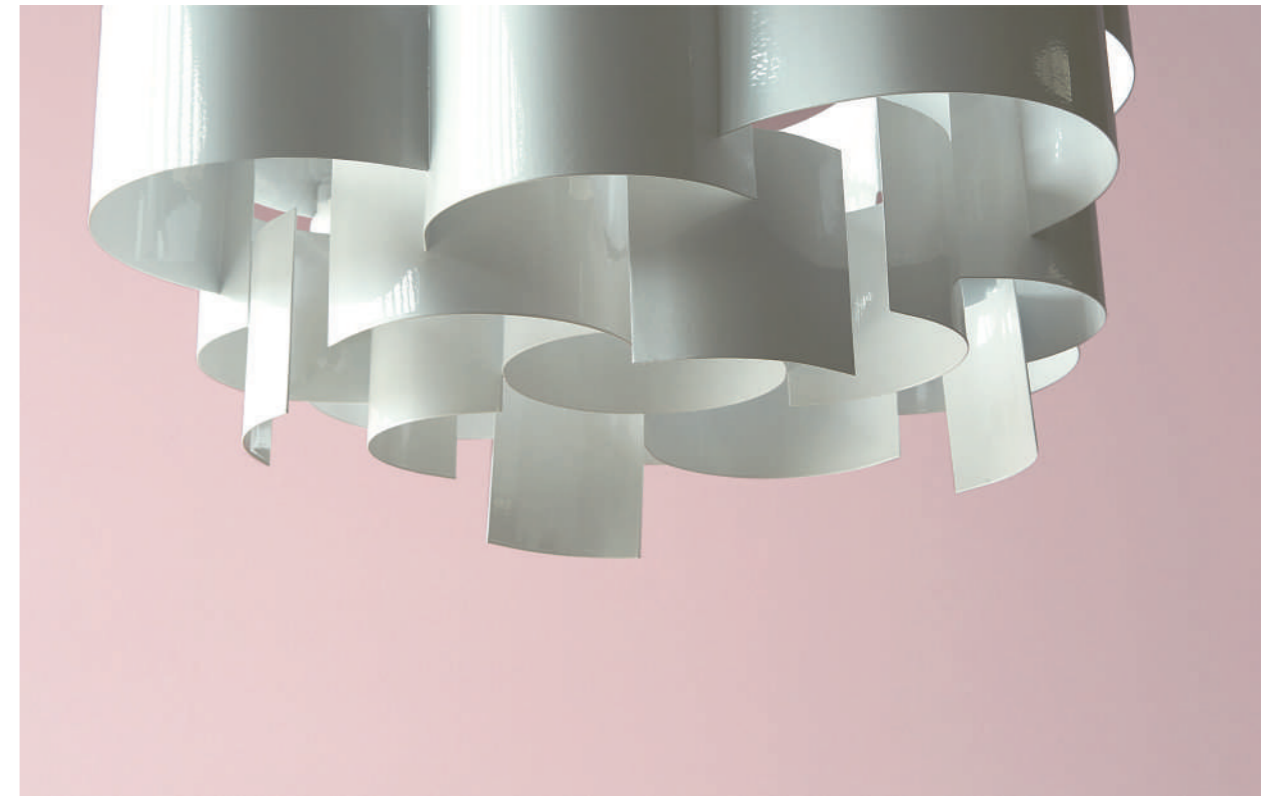

CLOUD

Lampadina
Light bulb

28W G9
A++-E

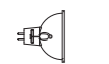

50W Gu10
A++-E

Metallo
Metal

V2553
Bianco lucido
Glossy white

Art. 6978/9

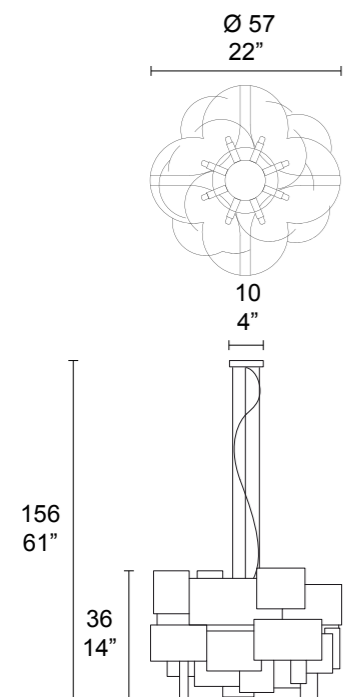

Lampadina
Light bulb

28W G9
A++-E



28W G9
A++-E

Metallo
Metal

V2553
Bianco lucido
Glossy white

Art. 6978/A2

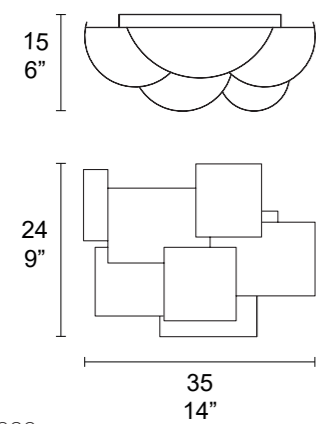

CAGE

UFFICIO TECNICO MM LAMPADARI



Qui la luce diviene forma, stile, design. Cage ha un carattere forte e definito che si sposa con il gusto per l'arredo multiculturale. Innovativa la piastra a led che crea un interessante gioco di luce.

Cage makes the light turn into the very design, shape, style. Its strong and defined essence matches the multicultural decor, with its innovative led plate which gives an interesting light play.

7080/1 01

7080/1 00



CAGE

Lampadina
Light bulb

Metallo
Metal

Diffusore
Diffuser

LED
LED BOARD
12/18 W 4000°K
A++-E

● V0199
Nero opaco
Matt black

○ Policarbonato bianco
Polycarbonate white

Art. 7080/1 00

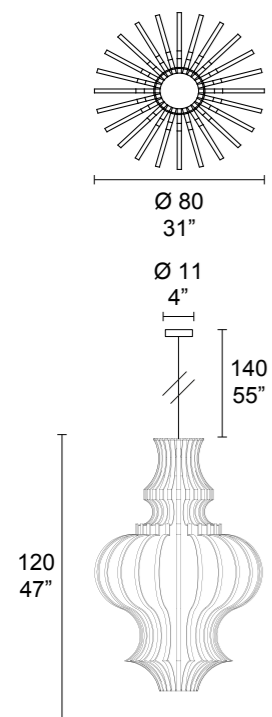

Art. 7080/1 01

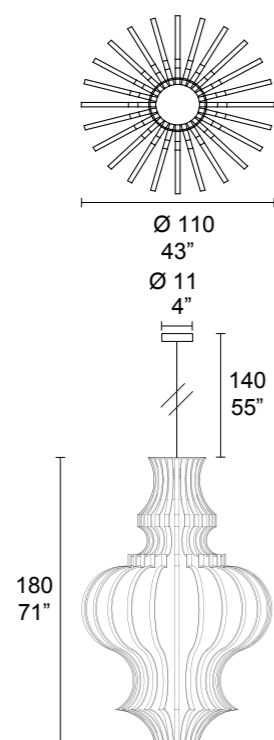



SKY

UFFICIO TECNICO MM LAMPADARI

Serie di lampade a parete e da terra, realizzate in metallo e decorate in finitura bianco opaco.

La linearità della collezione sposa la ricercatezza della diffusione della luce totalmente indiretta ed eterea, creando un binomio moderno/classico perfetto per ogni tipo di ambiente.

Series of wall and floor lamps, made of metal and decorated in matt white finish. The linearity of the collection combines the refinement of the diffusion of light totally indirect and ethereal, creating a modern/classical combination perfect for any type of environment.

6674/A1



6674/LT3

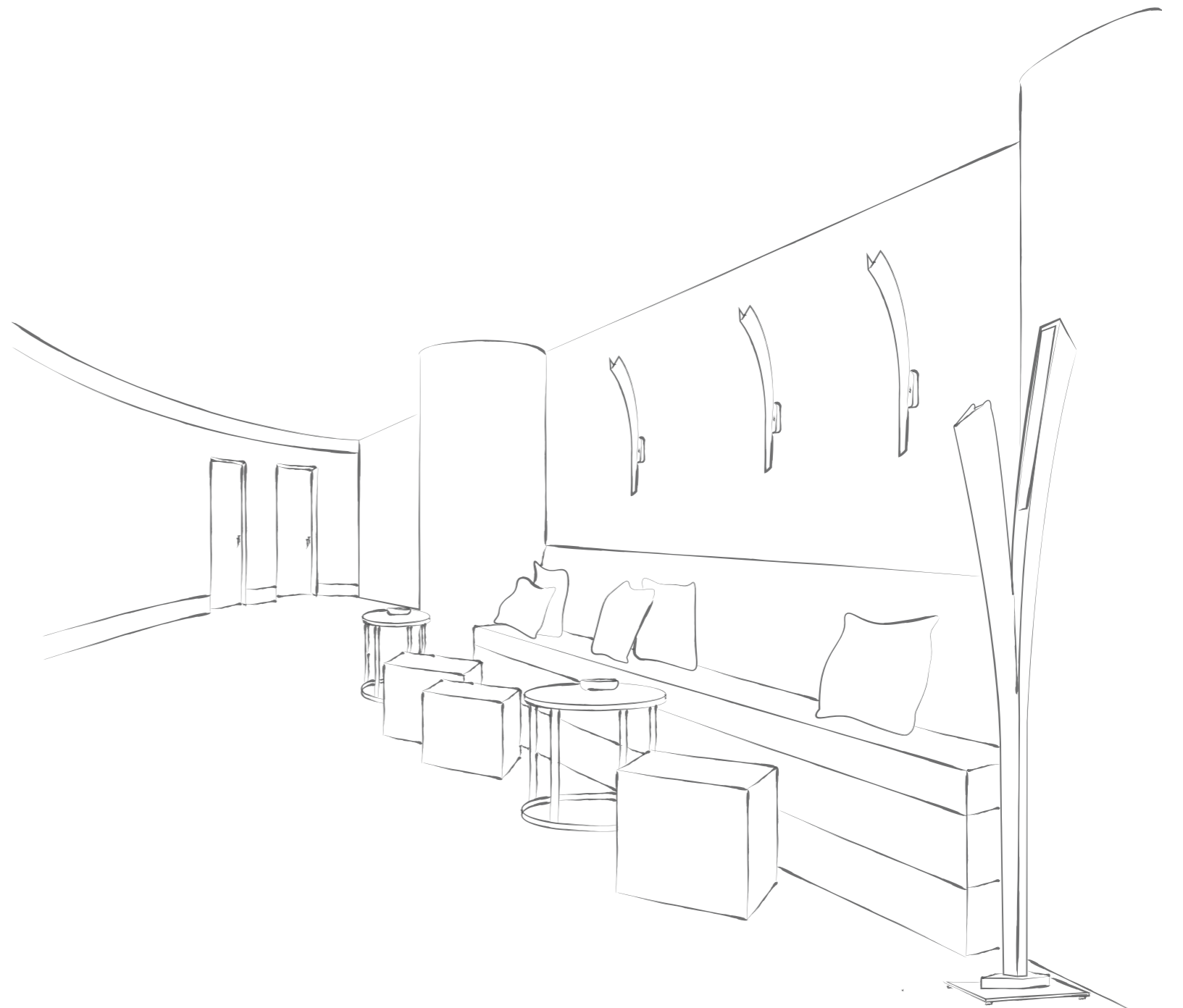

6674/A1

6674/LT3

SKY

Lampadina
Light bulb



Metallo
Metal



Art. 6674/LT3

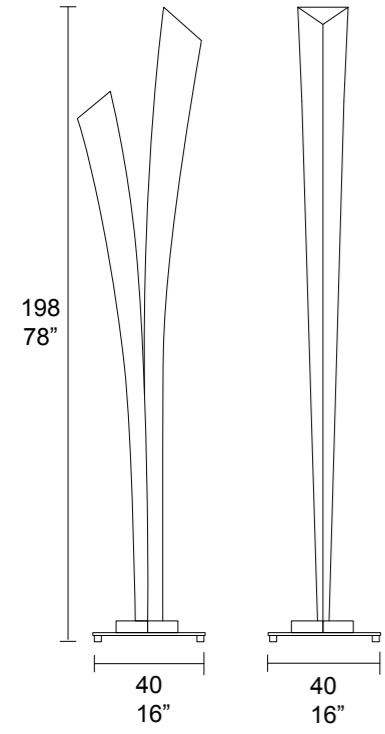

SKY

Lampadina
Light bulb

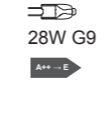

Metallo
Metal



Art. 6674/

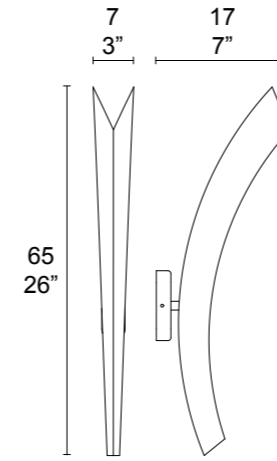

Art. 6674/

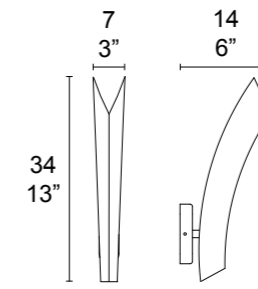

SASS

UFFICIO TECNICO MM LAMPADARI

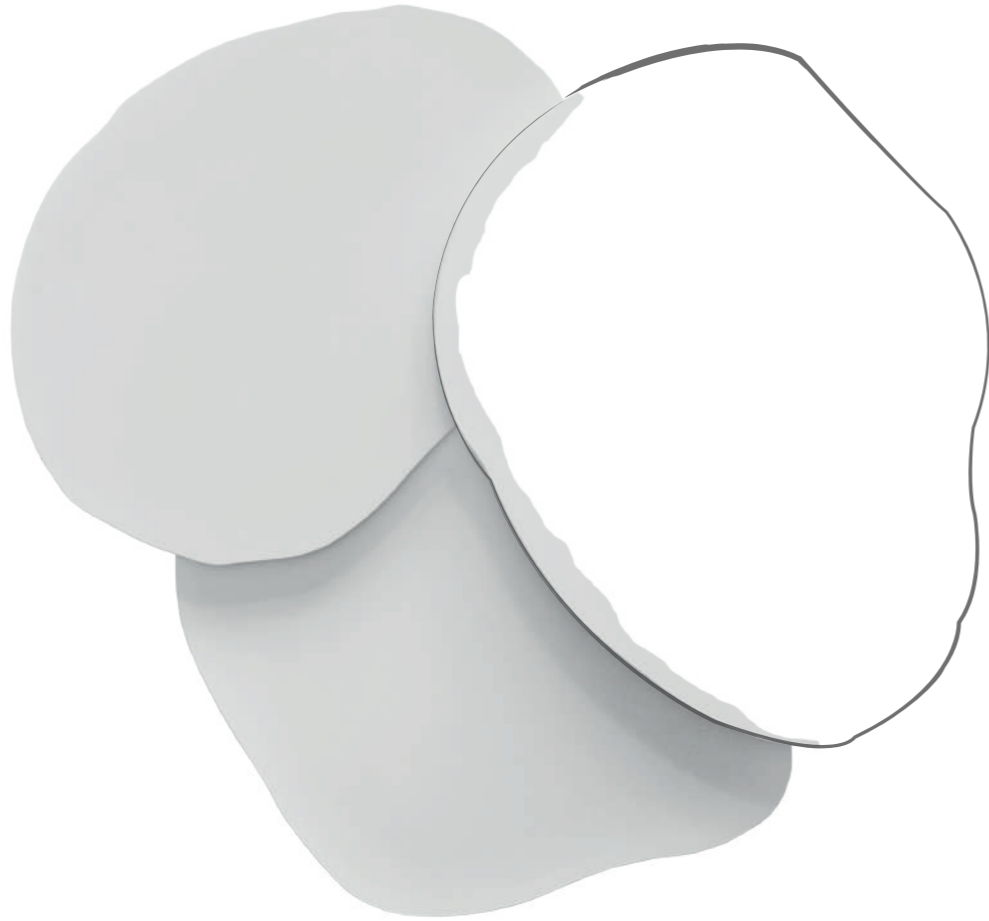

Lampade che si possono adattare sia a soffitto che a parete; sono realizzate con lamiere modulate in metallo, sovrapposte in più livelli ed adagiate a creare quasi una scultura. Decorate in bianco opaco giocano con la loro irregolarità le rendendole organiche facilmente integrabili e discrete.

7102/A3



Lamps that can be adapted both to the ceiling and to the wall; they are made with metal modulated sheets, superimposed in several levels and laid down to create almost a sculpture. Decorated in opaque white, they play with their irregularity, making them organic, easily integrated and discreet.



7102/P8

SASS

Lampadina
Light bulb

LED
3 x 4,5W
3000K
A++ → E

Metallo
Metal

V2907
Bianco opaco
Matt white

Art. 7102/A3

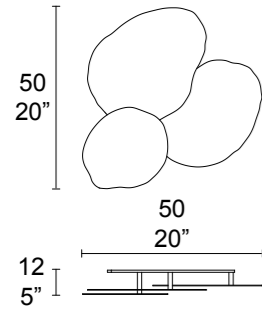

Art. 7102/P8

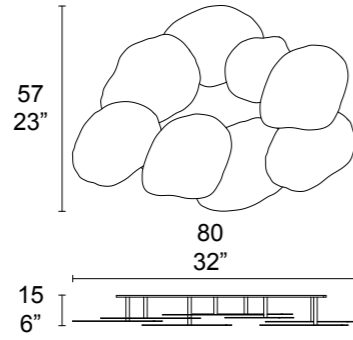

SCARABOCCHIO

UFFICIO TECNICO MM LAMPADARI

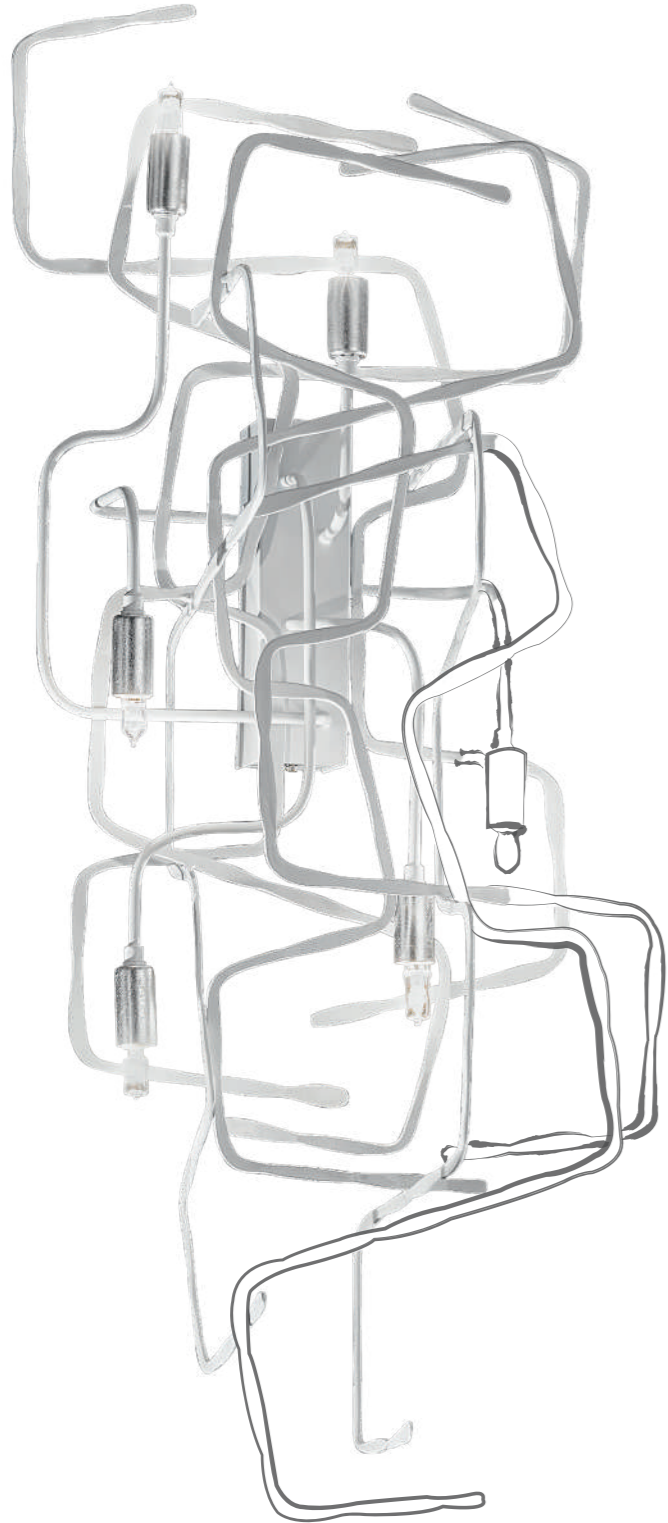

Spontanea e ironica. È così che si presenta sin dal primo sguardo questa lampada. Una struttura in metallo forgiato dai nostri esperti artigiani e che nobilita ed attualizza l'antica arte del lavoro fatto rigorosamente a mano, e che illumina e arreda con un gusto frizzante e ultra moderno.

Spontaneous and ironic. That's how this lamp looks from the first glance. A metal structure forged by our expert craftsmen and that ennobles and updates the ancient art of work done strictly by hand, and that illuminates and furnishes with a sparkling taste and ultra modern.

7081/A6

7081/12

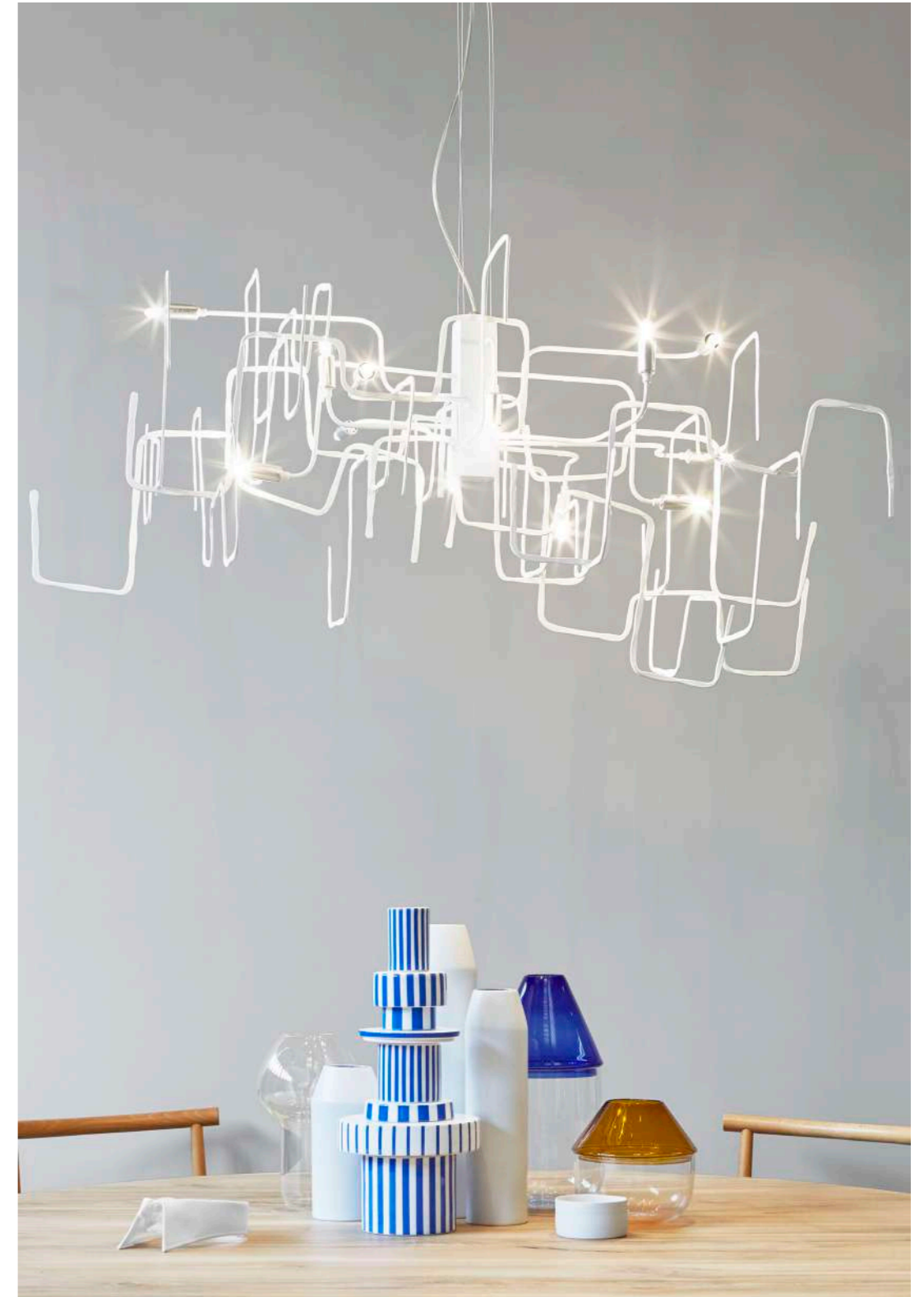

SCARABOCCHIO

Lampadina
Light bulb

28W G9
A++-E

Metallo
Metal

V2553
Bianco lucido
Glossy white

Art. 7081/12

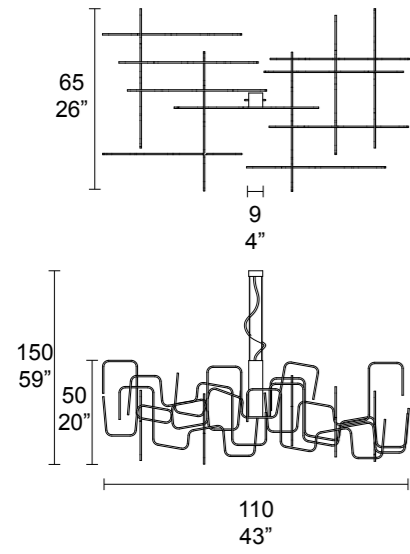

Art. 7081/A6

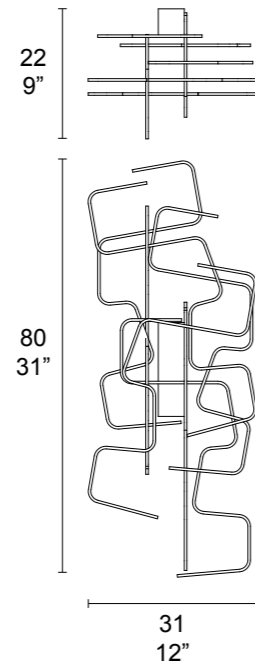

Art. 7081/P8

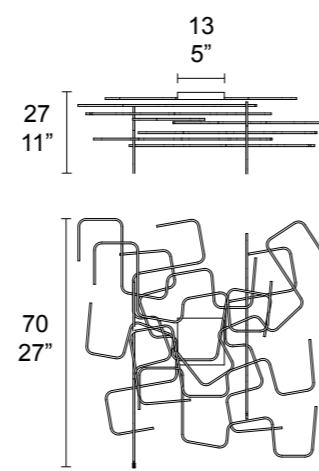

FILI

CHRISTIAN PICCOLO



D008/1 01



D005/1 01



D049/1 01

Strizza l'occhio alla Op-Art questa famiglia di chandelier in tondini metallici leggeri che esaltano le righe trasformandole in elemento geometrico e decorativo pervaso di semplicità e freschezza. Ecco come Fili nelle sue diverse forme celebra l'effetto millerighe. Una illuminazione diretta che arriva dall'alto ne enfatizza le forme e la rende una lampada dal gusto senza tempo.

Wink at Op-Art this family of chandeliers in light metal rods that enhance the stripes, transforming them into a geometric and decorative element full of simplicity and freshness. This is how Fili, in its different forms, celebrates the stripes effect. Direct lighting from above emphasises its forms and makes it a lamp with a timeless taste.



D007/1 01



D008/1 01

D005/1 01



FILI

Lampadina
Light bulb



50W Gu10



Metallo
Metal

- V1165
Oro verniciato
Coated gold
- V2721
Argento scuro
Dark silver
- V1607
Chromo lucido
Glossy chrome
- V2806
Rame lucido
Glossy copper

Art. D005/1 01

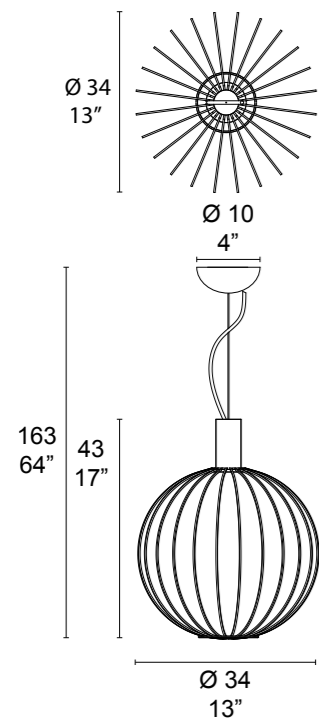

Art. D007/1 01

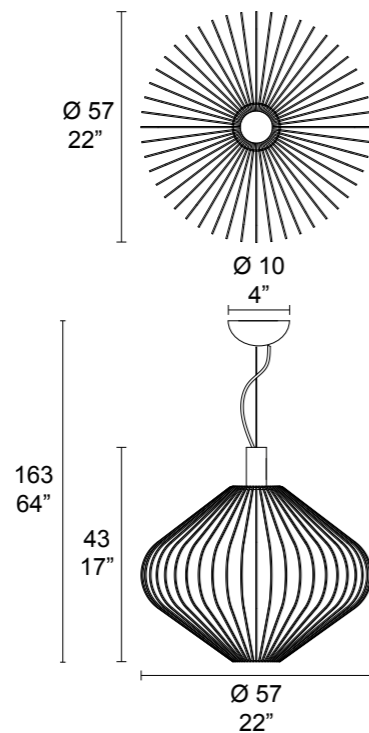

Art. D008/1 01

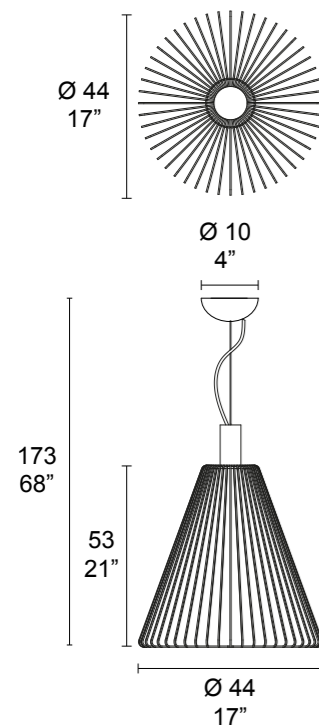

Art. D049/1 01

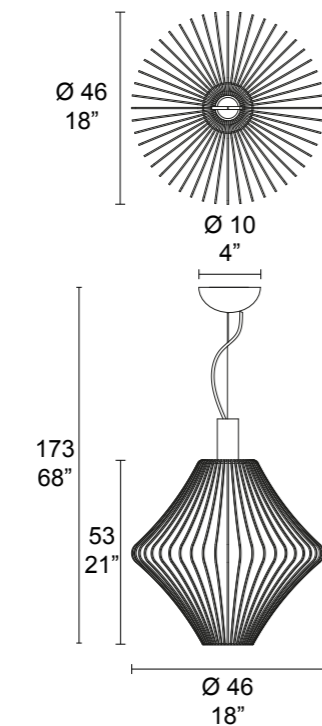



SILVESTRO

UFFICIO TECNICO MM LAMPADARI

Una luce leggera e graduata è diffusa da Silvestro, disponibile in versione applique e lampadario.

La struttura in metallo con braccia che si espandono a raggiera attorno alla base come in un mazzo di fiori, sostiene dei paralumi conici affusolati per un effetto d'impatto e sempre elegante.

A light and graduated light is diffused by Silvestro, available in wall and chandelier versions.

The metal structure with arms that expand radially around the base like a bunch of flowers, supports the conical lampshades tapered for an effect of impact and always elegant.

7076/A9





7076/21



SILVESTRO

Lampadina
Light bulb



Metallo
Metal



Diffusore
Diffuser

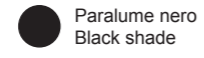

Art. 7076/21

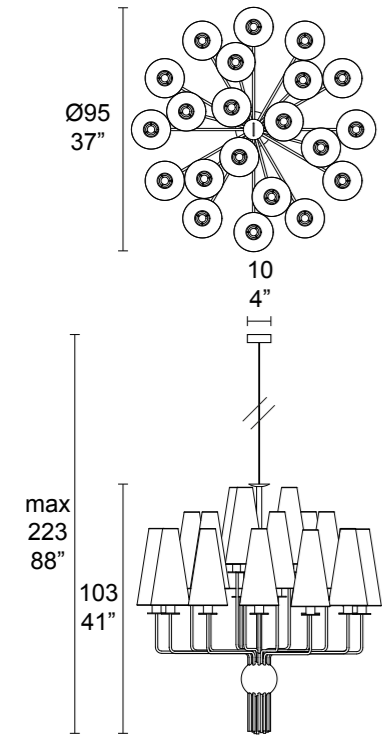

Art. 7076/A9

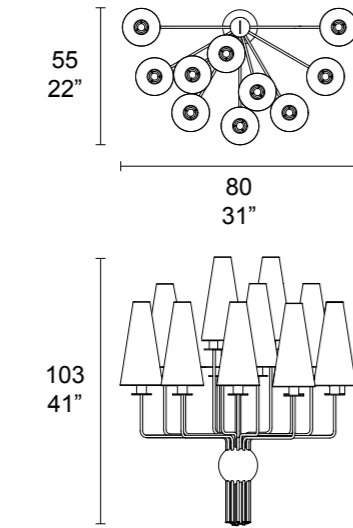

TRIMMING

PATRIZIA GUIOTTO



7096/A2

Questa lampada a candelabro trae ispirazione dalle figure mitologiche orientali che con le loro braccia rivolte al cielo raccolgono l'energia creativa per restituirla a ciò che le circonda. La finitura in argento lucido con dettagli in argento spazzolato ne enfatizzano la preziosità e la semplicità.

This candelabrum lamp is inspired by oriental mythological figures who, with their arms facing the sky, gather creative energy to return it to its surroundings. The polished silver finish with brushed silver details emphasize its preciousness and simplicity.

7096/16





7096/A2



TRIMMING

Lampadina
Light bulb



28W E14



Metallo
Metal

V2659
Argento lucido
Bright silver

Argento spazzolato
Brushed silver

Art. 7096/16

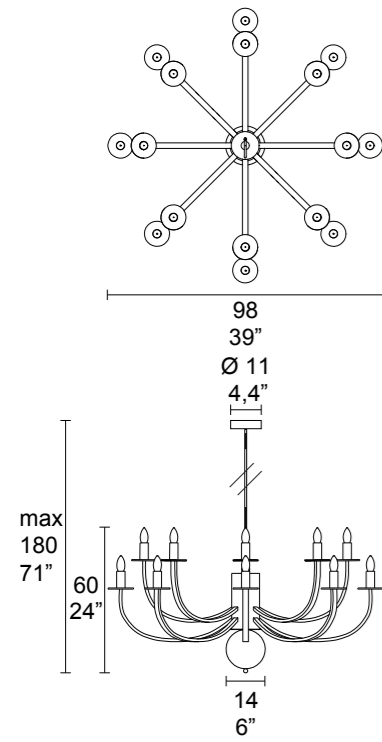

Art. 7096/A2

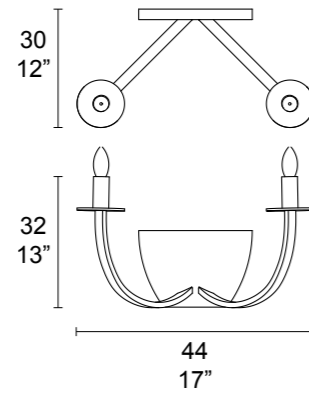

Art. 7096/A4

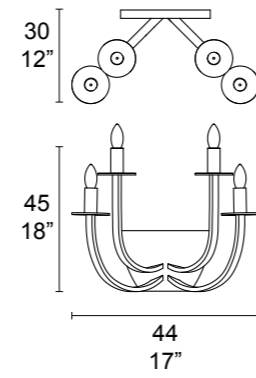

CHE FORMA HA UN PROGETTO BRILLANTE?

Il nostro team di tecnici è in grado di analizzare tutte le richieste in arrivo per preparare un servizio su misura (sulla base di un modulo tecnico o di un'idea del cliente). Ogni pezzo viene controllato e testato come garanzia di qualità e durata nel tempo dei nostri articoli. Richieste di soluzioni tecniche ed estetiche qualificate in termini di efficienza, sicurezza e adattabilità e trovano in MM Lampadari la risposta giusta.

WHAT SHAPE HAS A BRILLIANT PROJECT?

Our technician team can analyse all incoming requests to prepare a tailored service (based on a technical module or client's idea). Each piece is controlled and tested as a guarantee of quality and long-life across time to our items. Requests for technical and aesthetic solution qualified in terms of efficiency, security and adaptability and found in MM Lampadari the right answer.

BESPOKE

MM Lampadari è a tua disposizione per progettare e realizzare pezzi per l'hospitality in partnership con tecnici illuminotecnici, architetti e designer interni garantendo:

- Innovazione, tecnologia e creatività
- Flessibilità, affidabilità e sicurezza
- Tempestività nella consegna
- Garanzia di qualità e lunga durata del prodotto
- Design del prodotto
- Custom made
- Offerta contrattuale su un modulo tecnico
- Design per l'illuminazione interna con rendering 3D
- Assistenza all'installazione

MM Lampadari is at your disposal to design and realise pieces for hospitality in partnership with lighting technical people, architect and internal designer granting:

- Innovation, technology and creativity
- Flexibility, reliability and security
- Timeliness in the delivery
- Guarantee of quality and long life of the product
- Product design
- Custom made
- Contract supply on a technical module
- Design for internal lighting with 3D rendering
- Assistance to the installation

REFERENCE HOTEL AND PROJECTS



- Aenias Hotel (Ayia Napa, Cyprus)
- Avanti Hotel (Paphos, Cyprus)
- Belvedere Hotel (Wien, Austria)
- Central Station Dnepropetrovsk (Dnepropetrovsk, Ukraine)
- Centro Link (Singapore)
- Chèz Charles Restaurant (Dubai, United Arab Emirates)
- Chiesa Santi Cosma e Damiano (Villa San Giovanni, Italy)
- Chimento booth (Baselworld, Switzerland)
- Cleopatra Hotel (Nicosia, Italy)
- Elluxus Baku Boutique (Baku, Azerbaijan)
- Episkopiana Hotel (Limassol, Cyprus)
- Europa Hotel (Nicosia, Italy)
- Faros Hotel (Ayia Napa, Cyprus)
- Gasprom (Moscow, Private house of Russian President)
- Gipsoteca Canova (Possagno, Italy)
- Hilton Double Tree Hotel (Yerevan, Armenia)
- Hilton Hotel (Beer Sheva, Israel)
- Hilton Hotel (Nicosia, Italy)
- Hiroshima Airport (Japan)
- Home Restaurant (Milan, Italy)
- Intercontinental Hotel (Israel)
- Marinela Hotel (Sofia, Bulgaria)
- St. George Hotel (San Gilyan, Malta)
- Imperial Beach Hotel (Paphos, Cyprus)
- Istituto San Paolo Imi (Torino, Italy)
- Juliana Jewelry (Lugano, Italy)
- Korte Shops (Germany)
- Makati Shangri-La Hotel (Manila, Philippines)
- Malama Holiday Village (Paralimni, Cyprus)
- Mercure Resort & SPA Hotel (Krynica Zdrój, Poland)
- Meu Manna Golf Club (Tokyo, Japan)
- Monastero (Bad Gandersheim, Germany)
- Neue Post Hotel (Wien, Austria)
- Nissaki Beach Hotel (Corfu, Greece)
- Nomad Design Hotel (Basel, Switzerland)
- Nuovo Hotel (Budapest, Hungary)
- Pandenus Hotel (Milan, Italy)
- Park Casinò Hotel (Nova Gorica, Slovenia)
- Ramada Hotel (Dubai, United Arab Emirates)
- Residenza del Ministro della Difesa (Saudi Arabia)
- Residenza del Presidente Della Repubblica (Cyprus)

- Resturant Tom.r (St.Andrà in Sausal, Austria)
- Ritz Carlton Hotel (Jeddah, Saudi Arabia)
- Ritz Hotel (Dubai, United Arab Emirate)
- Roberto Coin booth (Baselworld, Switzerland)
- Royal Palace (Nicosia, Italy)
- Sheraton Hotel (Hong Kong, China)
- Sheraton Moriah Hotel (Eilat, Israel)
- Sokos Hotel Presidentti (Helsinki, Finland)
- Vladivostok Station (Vladivostok, Russia)
- Zer0tt8no9ve (Salerno, Italy)
- Yellow Door (Barcelona, Spain)
- Dresscode Hotel (Paris, France)
- Queens Caffé Bistrot (Molfetta, Italy)
- La Battigia ristorante (Bari, Italy)
- The Kloof 145 House (Capetown, South Africa)
- Vista Restaurant (Willemstad NB, Netherlands)
- The Wing Soho (New York, USA)

HOME CUSTOM MADE

Crediamo che un'ottima idea nasconda un potenziale inimitabile se immaginata a più mani. Le nostre, quelle del cliente, quelle dei designer. Le chiamiamo collaborazioni ma sono, da sempre, il motore del nostro crescere. La chiave per la creazione di pezzi unici pensati a misura d'ogni progetto. Anche il più ambizioso.



Residential VIII, Amsterdam, Holland



Villas del Piantini, Santo Domingo, Dominican Republic

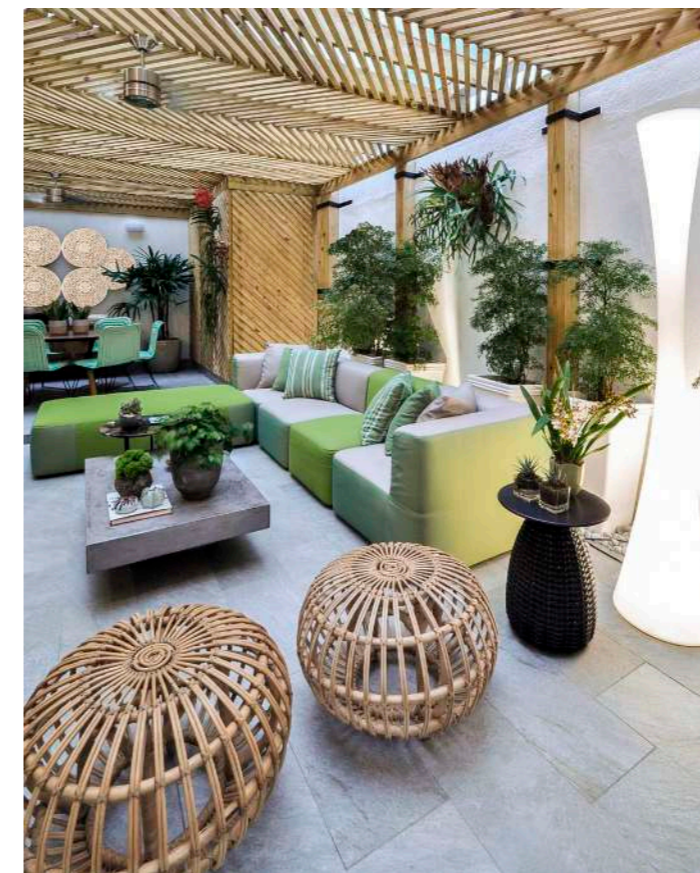

We believe that a great idea hides an inimitable resource if managed by plenty of hands. Our hands, those of customer and those of designers. People call them partnerships but they are the engine of our growth. Key to the realization of rare pieces customized for every project. Even for the most ambitious one.



Hotel Majestic, Madonna di Campiglio, Italia



Tom Riederer, Sankt Andrä Im Sausal, Austria





Vista Restaurant, Willemstad NB, Netherlands

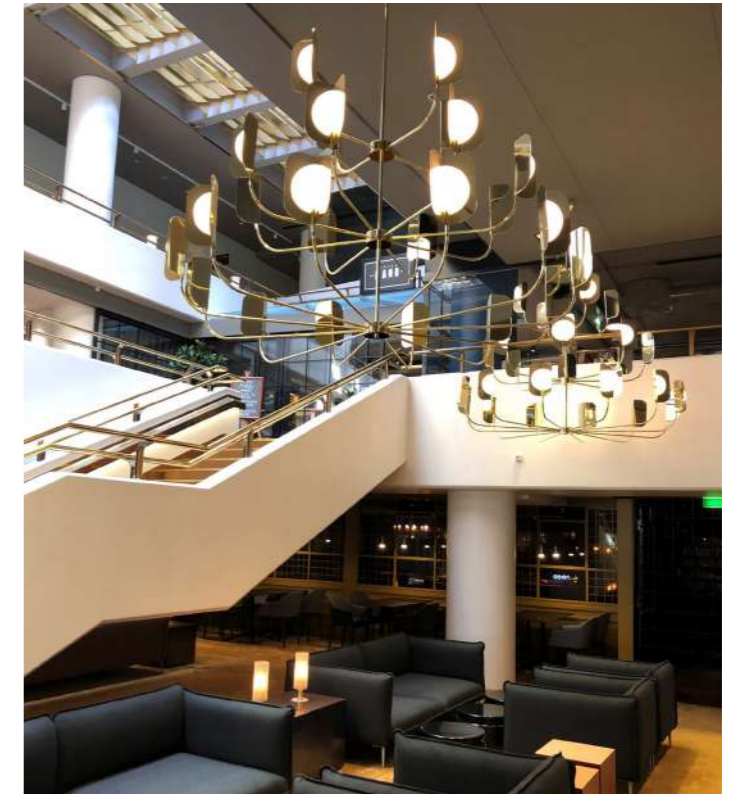

Hotel Presidentti, Helsinki, Finland



VISUAL CREATIVE DIRECTION & STYLING

Laura Pozzi
MM Lampadari

PHOTO

Federico Marin
Alessandro di Bon
Antonio Campanella
Studio Rocci

LOCATION

Francesco Venturato
Doimo Cucine

GRAPHICS

Cristina Robazza

COLOUR CALIBRATION

GM studio1

PRINT

Tipografia Asolana
Stampato a giugno 2019

THANKS TO:

Agape
Arlex Italia
Ceramiche Milesi
Collezioni
Doimo Cucine
F.lli Calegari
Hafrogeromin
Il Cesello
Jesse
Kasthall
Kreoo
Lema
Little Owl
Made a Mano
Marazzi Group
Matteo Pala
Matteo Zorzenoni
Mauro Bolognesi
Miniforms
Molteni & C
Moroso
Officina N°3
Scapin
Sculpture Jeux
Sonia Pedrazzini
Roncato Valigeria
Rubinetteria Giulini
Woobag
Woodmoon

Tutti i prodotti MM Lampadari S.r.l. che rientrano nell'ambito di applicazione della direttiva europea EMC 89/336, 73/23 e 93/68 EEC, soddisfano i requisiti richiesti e recano la marcatura. Il simbolo è posto sull'imballo e sul prodotto. Ogni articolo prodotto presentato nel catalogo è prodotto e decorato artigianalmente, pertanto lievi differenze nelle dimensioni costituiranno quel carattere di unicità proprio della lavorazione manuale.

All the products of MM Lampadari S.r.l. included in the current European directives EMC 89/336, 73/23 and 93/68 EEC, meet every requirements and are marked. The symbol is placed on the packaging and on the products. Every item presented in the catalogue is produced and decorated by craftsmen. Hence, slight differences on the size and decorations are the result of the unique quality of handwork.



MM Lampadari S.r.l. si riserva il diritto di intervenire in qualunque momento e senza preavviso per apportare le modifiche che ritenesse più opportune per migliorare il prodotto o in risposta a qualsiasi esigenza di carattere normativo costruttivo o commerciale.
MM Lampadari S.r.l. reserves its right to intervene in every moment and without forewarning in order to make the modifications more suitable to improve the product or reply to each legal, manufacturing or commercial requirement.

© MM LAMPADARI è vietata la riproduzione anche parziale di questo catalogo / It is forbidden to reproduce any part of this catalogue



www.mmlampadari.com